

Code	Colour	Des.	Pos.	Description
C1	Black	C1	C 4	Connector, 66-pole
C5	Black	C5	B 1	Connector, 2-pole
BK	Black	C100	D 5	Connector, 66-pole
BN	Brown	C110	B 5	Splice, frame, VIS
RD	Red	C111	C 5	Splice, frame, VIS
OG	Orange	C409	C 4	Splice, bumper, VIS
YE	Yellow	C410	C 3	Splice, bumper, VIS
GN	Green	C450	C 5	Connector, 2-pole, VIS
BU	Blue	G13	D 4	Ground, torpedo wall
VT	Violet	G21.A	C 4	Ground, cab front
GY	Grey	G21.B	C 3	Ground, cab front
WH	White	G21.B	C 4	Ground, cab front
PK	Pink	G21.C	C 2	Ground, cab front
		G22.A	C 3	Ground, cab front
		G22.B	C 1	Ground, cab front
		L9	B 4	Dirac ind light, front
		L10	B 3	Dirac ind light, front
		L67	B 5	Side marker lamp
		L68	B 6	Side marker lamp
		L69	B 5	Side marker lamp
		L70	B 6	Side marker lamp
		L96	B 6	Side marker lamp
		L97	B 5	Side marker lamp
		L98	B 6	Side marker lamp
		L99	B 5	Side marker lamp
		L121	B 4	Category six lamp
		L122	B 3	Category six lamp
		L127	B 4	Gasdischarge lamp, left
		L128	B 3	Gasdischarge lamp, right
		L131	B 4	Gasdischarge lamp, side marker, left
		L132	B 3	Gasdischarge lamp, side marker, right
		M5	B 2	Motor, head lamp wiper
		M6	B 2	Motor, head lamp wiper, right
		M7	B 2	Motor, windscreen washer
		M8	B 2	Motor, headlamp washer
		N2/N17	B 1	Signal horn

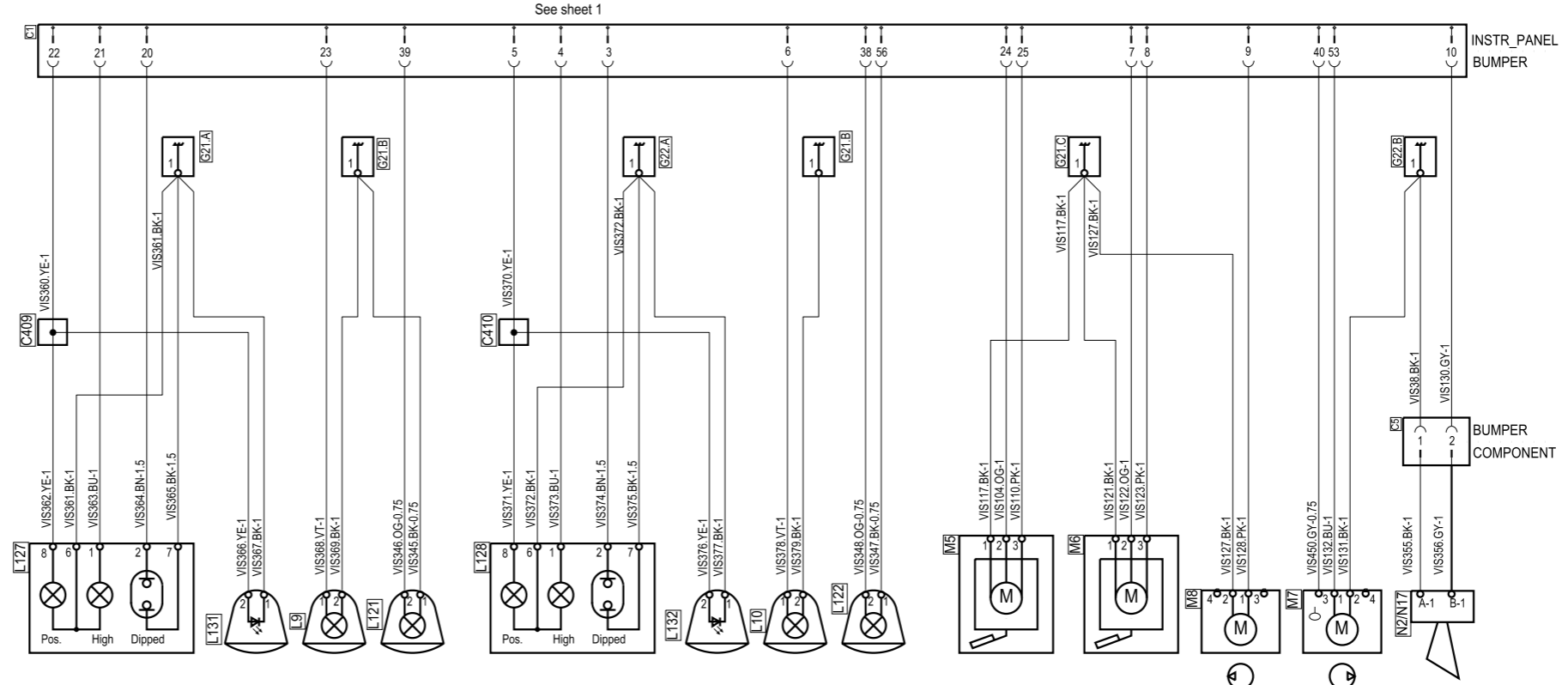
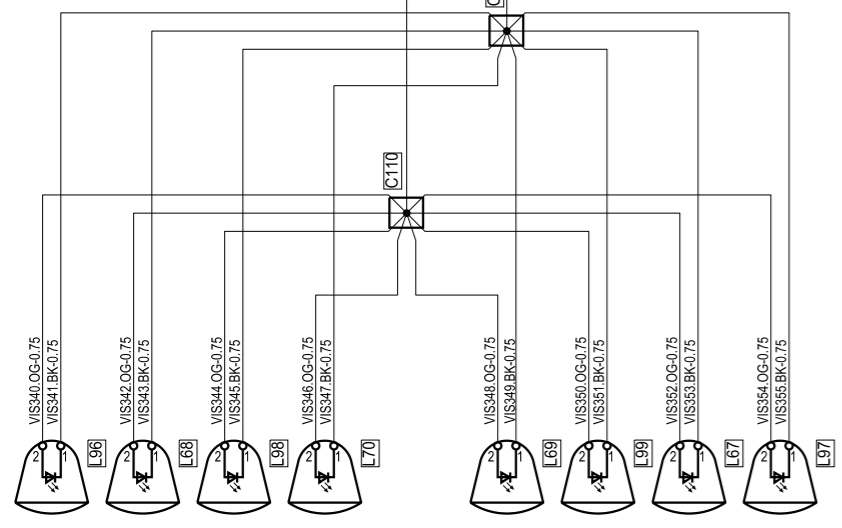
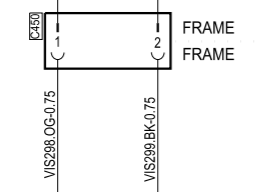
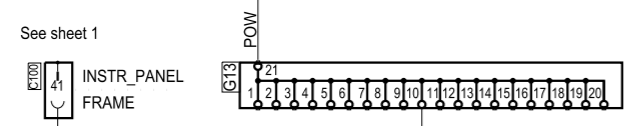

S-order equipment connected:  
Cable h VIS SML SB Frame.

STD  
4247

**SCANIA**

Circuit Diagram:

**VIS**

Drawing No.-  
Sheet-Rev: 1428523-3-18

N.B. The copyright and ownership of this drawing including associated computer data are and will remain ours. They must not be copied, used or brought to the attention of any third party without prior permission (C) Scania, Sweden