

Des.	Pos.	Description
C102	E 6	Connector, 66-pole
C472	C 5	Connector, 3-pole
C476	C 4	Connector, 3-pole
C477	C 7	Connector, 3-pole
C478	C 6	Connector, 3-pole
E43.C	F 5	Control unit, EBS
T11	B 8	Sensor speed, Front LH
T12	B 5	Sensor speed, Front RH
T39	B 7	Sensor lining wear, Front LH
T40	B 4	Sensor lining wear, Front RH
T87	B 7	Sensor speed, LH
T88	B 5	Sensor speed, RH
T89	B 6	Sensor, lining wear, LH
T90	B 4	Sensor, lining wear, RH
V82	D 6	Pressure control module, Front
V83	D 4	Pressure control module, Add2

**Colour code of electric cables**

Code	Colour
BK	Black
BN	Brown
RD	Red
OG	Orange
YE	Yellow
GN	Green
BU	Blue
VT	Violet
GY	Grey
WH	White
PK	Pink

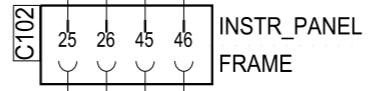
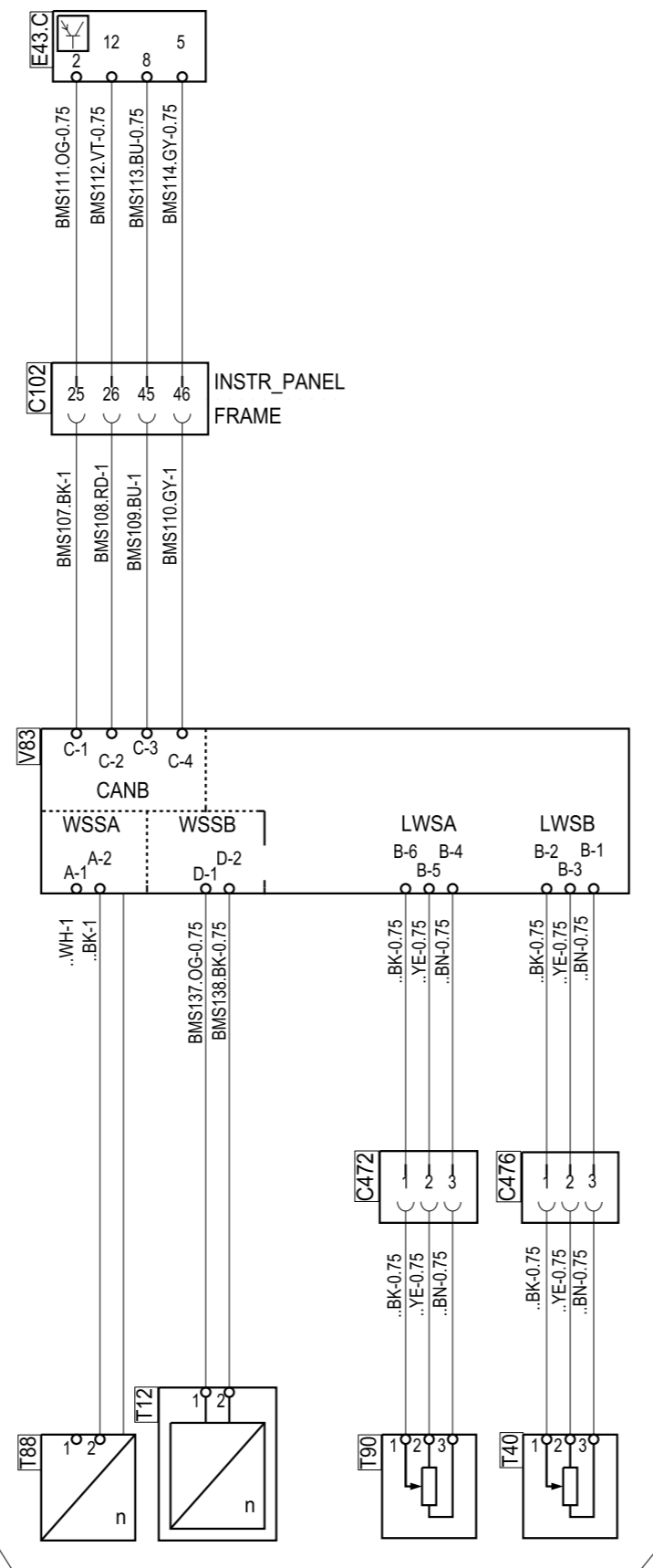
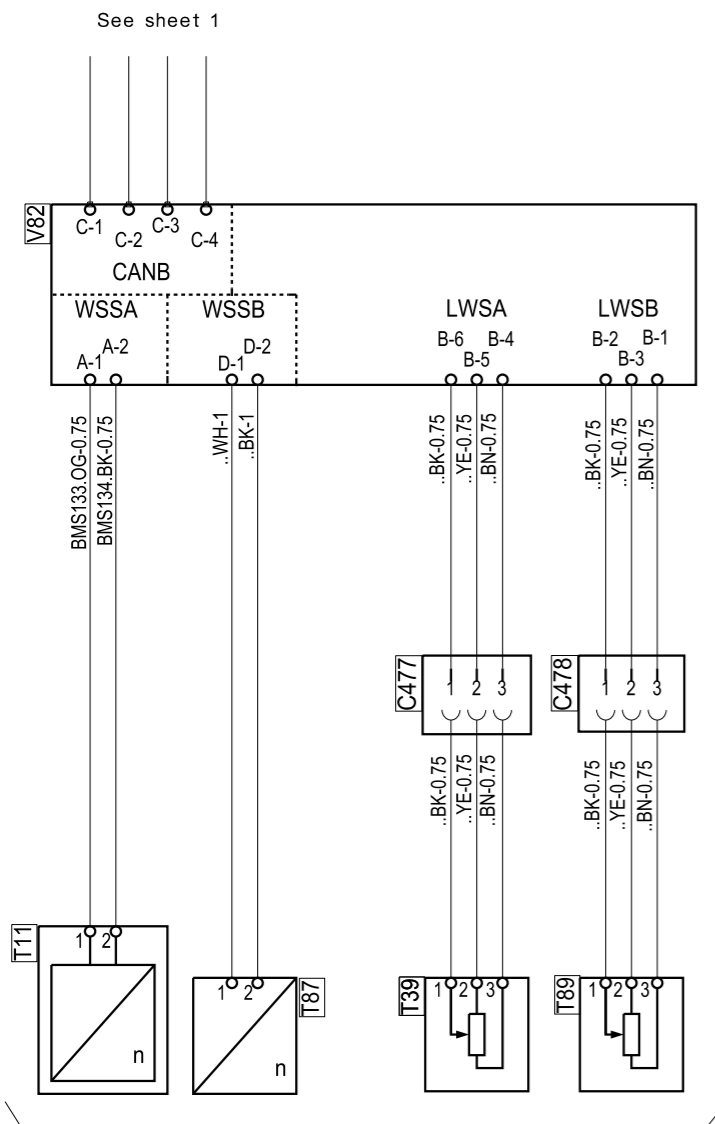

First and second front axle LH side

First and second front axle RH side

Valid for two front axles

STD  
4247

**SCANIA**

Circuit Diagram:

**BMS EBS**

Drawing No.-  
Sheet-Rev: 1452080-7-6

N.B. The copyright and ownership of this drawing including associated computer data are and will remain ours. They must not be copied, used or brought to the attention of any third party without prior permission (C) Scania, Sweden