

Cable designation	
AWD35 . OG - 1	
Cable marking	
Cable colour (Orange)	
Conductor area (mm ²)	

Des.	Pos.	Description
B41	B 5	Switch, high range
B42	B 5	Switch, low range
B43	B 5	Switch, high split
B44	B 4	Switch, low split
C106	C 5	Splice, 1-pole
C109	C 4	Splice, 1-pole
C123	C 2	Splice, 1-pole
C496	C 4	Connector, 7-pole
C497	C 3	Connector, 7-pole
C498	C 2	Connector, 7-pole
T17	B 5	Sensor, speed
V13	B 2	Solenoid valve, power take off EG
V20	B 4	Solenoid valve, side stroke right
V21	B 4	Solenoid valve, side stroke left
V22	B 3	Solenoid valve, neutral
V23	B 3	Solenoid valve, length stroke, backwards
V24	B 3	Solenoid valve length stroke, forwards
V62	B 2	Solenoid valve, low split
V63	B 2	Solenoid valve, low range
V77	B 2	Solenoid valve, high split
V78	B 2	Solenoid valve, high range

Colour code of electric cables	
Code	Colour
BK	Black
BN	Brown
RD	Red
OG	Orange
YE	Yellow
GN	Green
BU	Blue
VT	Violet
GY	Grey
WH	White
PK	Pink

D

C

B

A

D

C

B

A

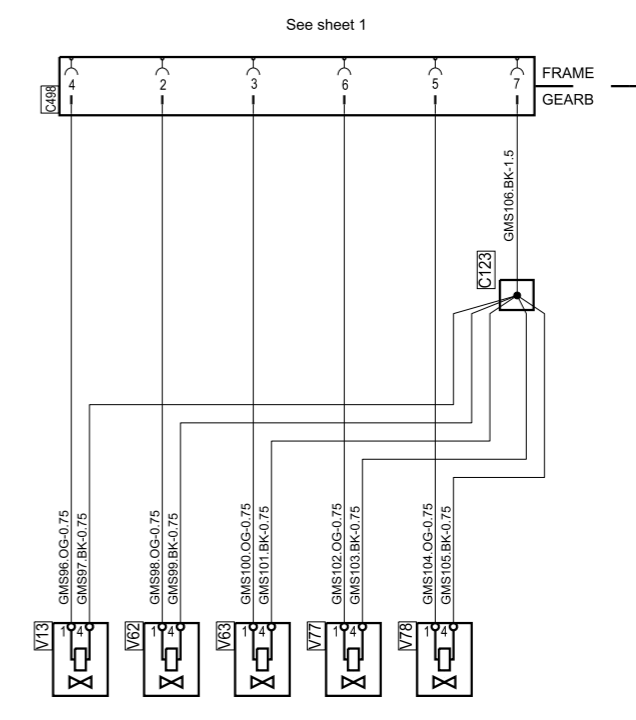
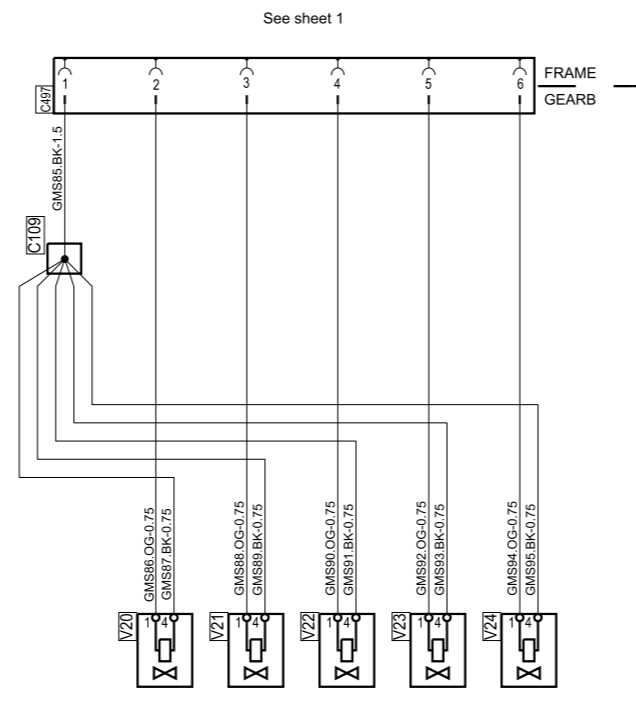
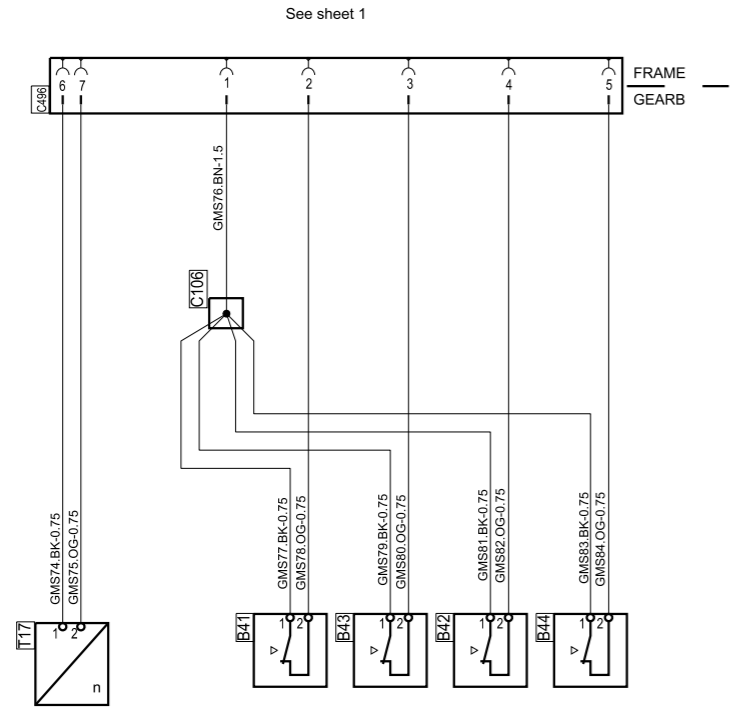

ADR

STD
4247



Circuit Diagram:

GMS OPC3

Drawing No.-
Sheet-Rev: **1453767-2-7**

N.B. The copyright and ownership of this drawing including associated computer data are and will remain ours. They must not be copied, used or brought to the attention of any third party without prior permission (C) Scania, Sweden