

PTO AWD / Split shaft

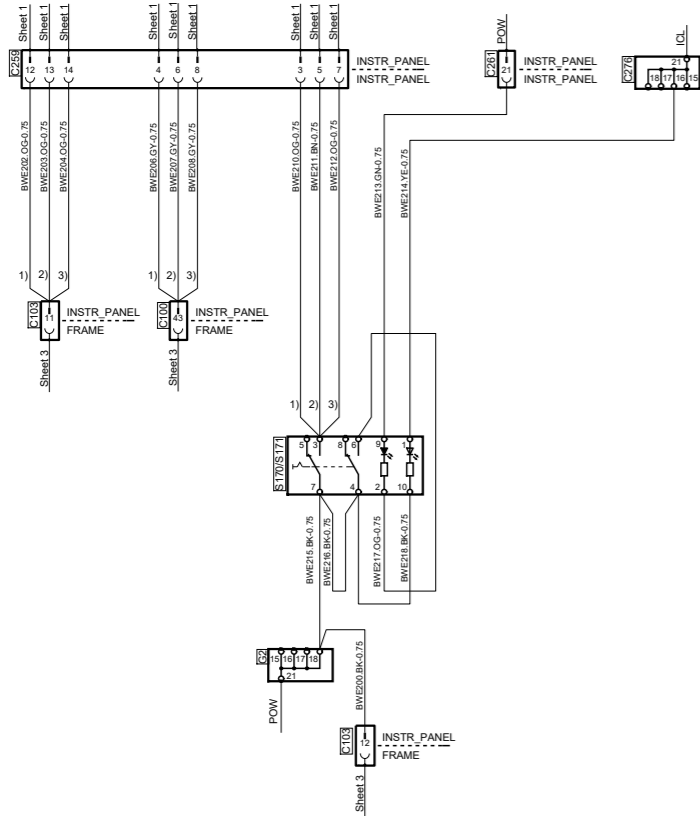

Use 1) when EG without or 1EG or 2EG and ED without or 1ED
 Use 2) when 2ED and EK
 Use 3) when 2ED and no EK

PTO ED

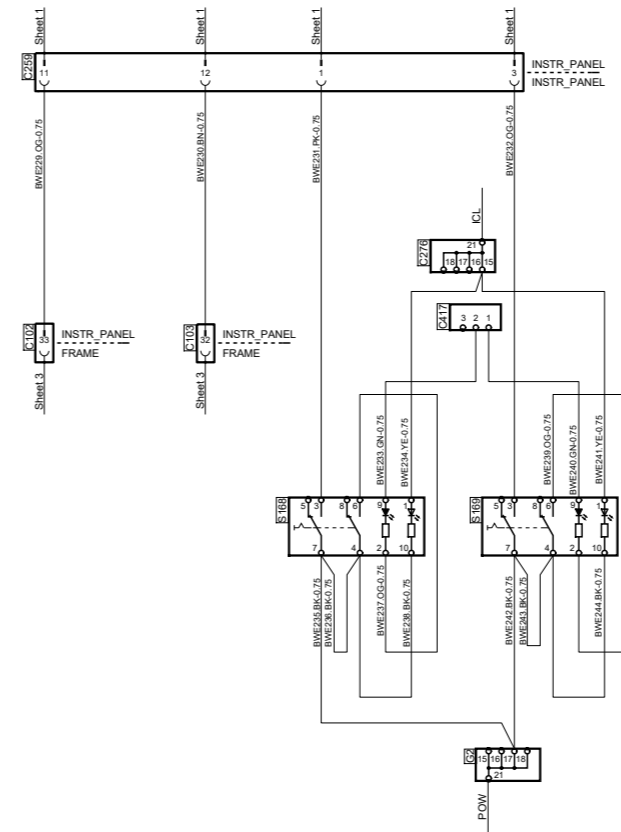

PTO EK

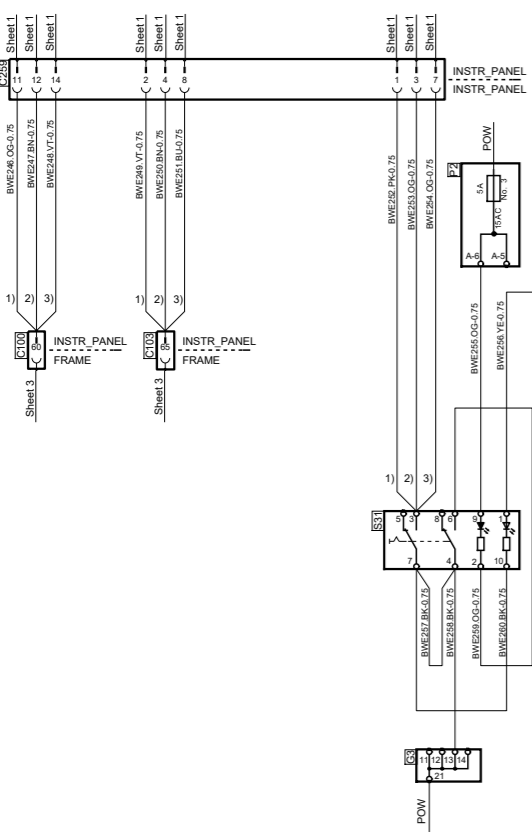

Use 1) when 2EG and SS or AWD
 Use 2) when 2EG
 Use 3) when EG without or 1EG

PTO EG

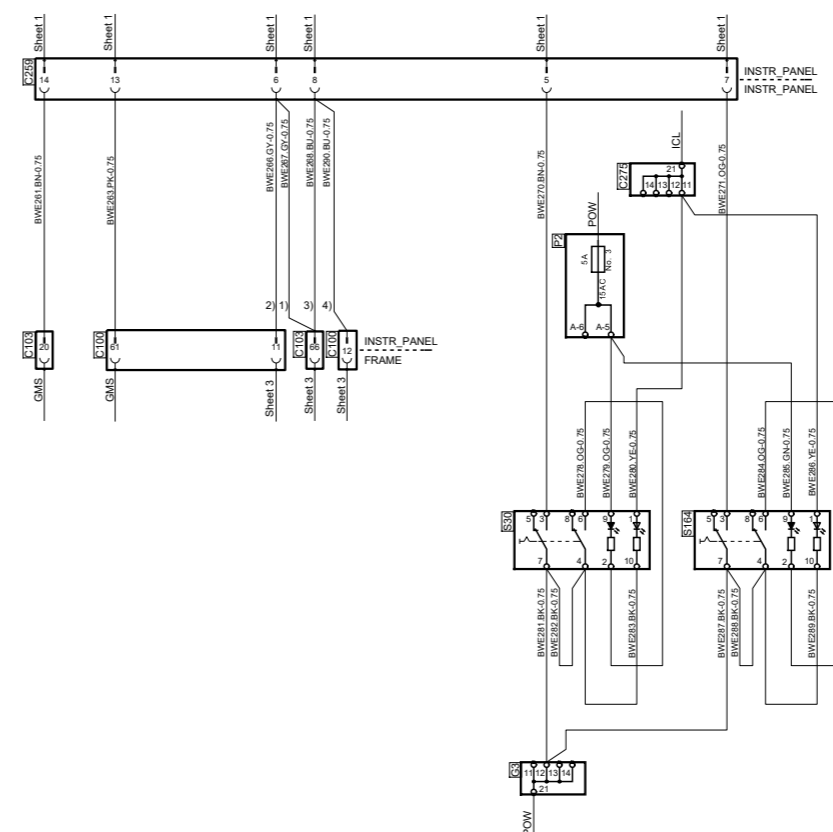

1) EG1, EG side
 2) EG1, EG rear
 3) EG2, EG rear together with EG side
 4) EG2, double rear or EG2 prep

Cable designation		Colour code of electric cables		Pos.		Description	
AWD35	OG - 1	C100	Black	E 8	Connector, 66-pole		
		C100	Black	B 8	Connector, 66-pole		
		C100	Black	B 4	Connector, 66-pole		
		C100	Black	B 3	Connector, 66-pole		
		C102	Red	E 4	Connector, 66-pole		
		C103	Orange	E 8	Connector, 66-pole		
		C103	Orange	E 4	Connector, 66-pole		
		C103	Yellow	E 8	Connector, 66-pole		
		C103	Yellow	B 8	Connector, 66-pole		
		C103	Green	B 4	Connector, 66-pole		
		C103	Green	B 3	Connector, 66-pole		
		C259	White	F 8	Connector, 21-pole		
		C259	White	F 4	Connector, 21-pole		
		C259	White	C 8	Connector, 21-pole		
		C259	White	C 4	Connector, 21-pole		
		C281	White	F 7	Connector, 21-pole		
		C275	White	C 3	Joint connector, instr light		
		C275	White	B 7	Joint connector, instr light		
		C276	White	E 3	Joint connector, instr light		
		C276	White	F 8	Joint connector, instr light		
		C417	White	E 3	Cut cable		
		G2	White	D 3	Joint connector, ground		
		G2	White	D 7	Joint connector, ground		
		G3	White	A 3	Joint connector, ground		
		G3	White	A 7	Joint connector, ground		
		P2	White	B 3	Central electric unit		
		P2	White	C 7	Central electric unit		
		S39	White	A 3	Switch, PTO EG1		
		S31	White	A 7	Switch, PTO EK		
		S164	White	A 2	Switch, PTO EG2		
		S168	White	D 3	Switch, PTO ED		
		S169	White	D 3	Switch, PTO EG2		
		S170/S171	White	D 7	Switch, PTO AWD / Split shaft		



Circuit Diagram: BWE

Drawing No.: 2038974-2-3
 Sheet-Rev:

N.B. The copyright and ownership of this drawing including associated computer data are and will remain ours. They must not be copied, used or brought to the attention of any third party without prior permission (C) Scania, Sweden