

PTO AWD / Split shaft

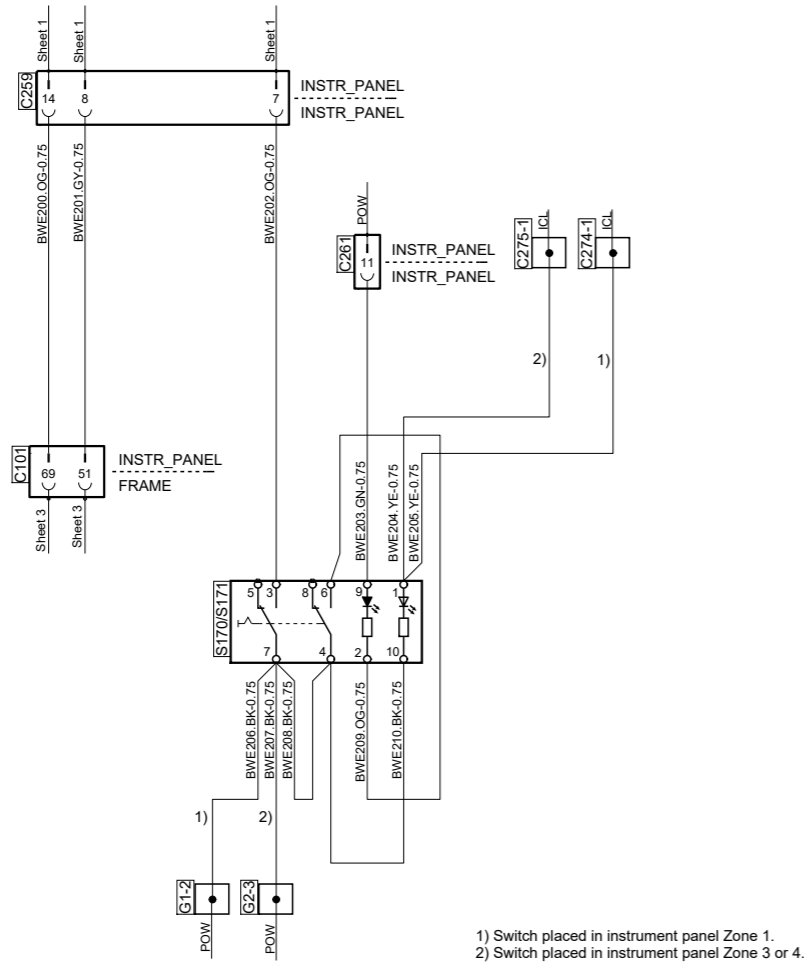

PTO ED

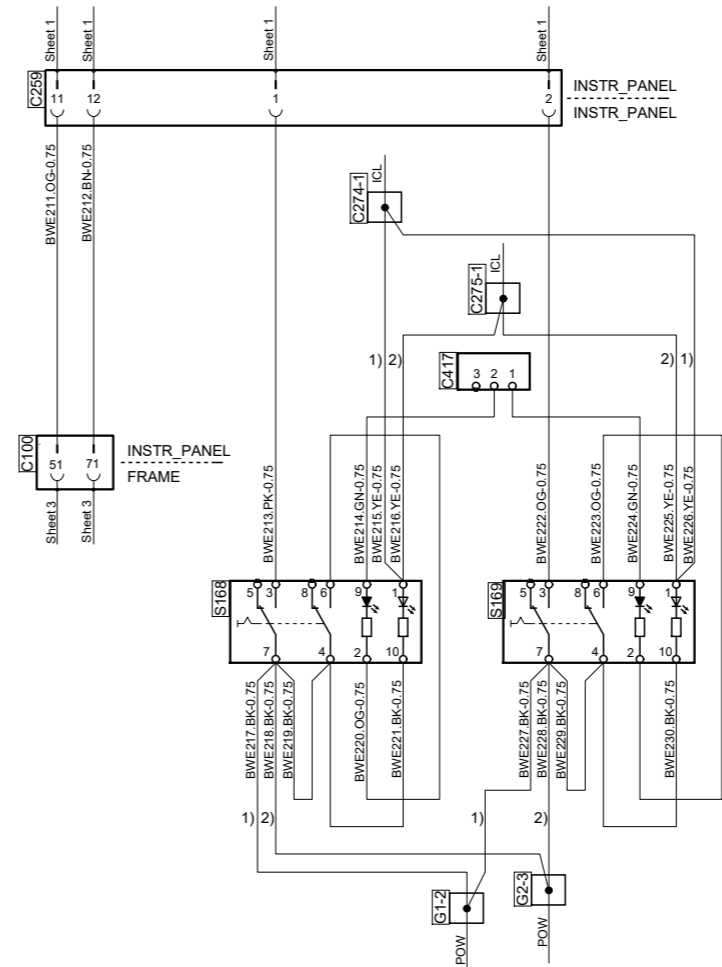

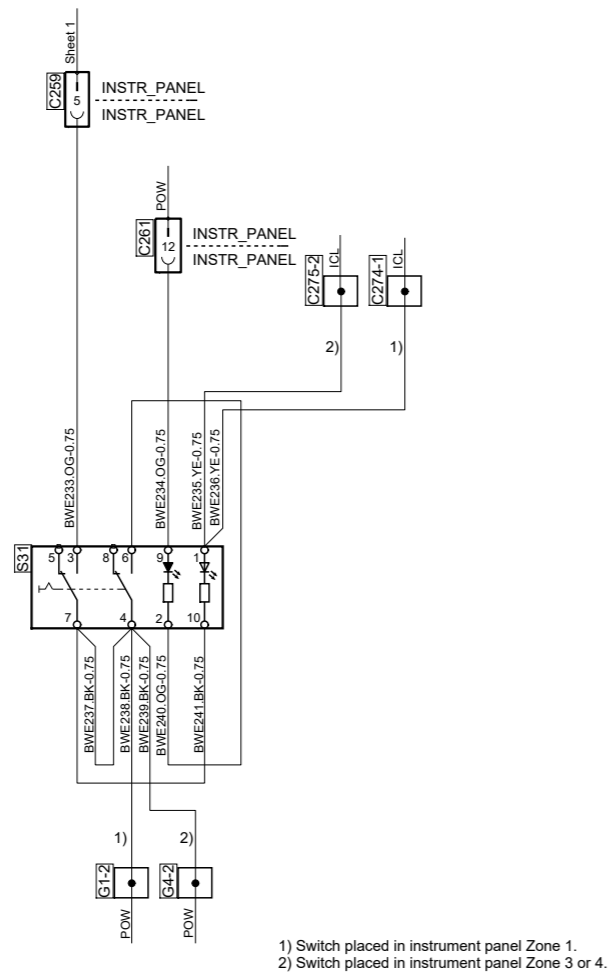

Cable designation		Colour code of electric cables		Des.	Pos.	Description
AWD35 OG - 1		Code	Colour	C100	E 4	Connector, 72-pole
Cable marking		BK	Black	C101	E 8	Connector, 72-pole
Cable colour (Orange)		BN	Brown	C259	C 4	Connector, 21-pole
Conductor area (mm ²)		RD	Red	C259	C 8	Connector, 21-pole
		OG	Orange	C259	F 4	Connector, 21-pole
		YE	Yellow	C259	F 8	Connector, 21-pole
		GN	Green	C261	B 4	Connector, 21-pole
		BU	Blue	C261	B 7	Connector, 21-pole
		VT	Violet	C261	E 7	Connector, 21-pole
		GY	Grey	C274-1	C 3	Splice, instrument light
		WH	White	C274-1	C 6	Splice, instrument light
		PK	Pink	C274-1	F 3	Splice, instrument light
				C274-1	F 6	Splice, instrument light
				C275-1	E 3	Splice, instrument light
				C275-1	F 6	Splice, instrument light
				C275-2	C 3	Splice, instrument light
				C275-2	C 6	Splice, instrument light
				C417	E 3	Cut cable, BWE
				G1-2	A 4	Splice, ground
				G1-2	A 7	Splice, ground
				G1-2	D 3	Splice, ground
				G1-2	D 7	Splice, ground
				G2-3	A 3	Splice, ground
				G2-3	D 3	Splice, ground
				G2-3	D 7	Splice, ground
				G4-2	A 3	Splice, ground
				G4-2	A 6	Splice, ground
				S30	B 4	Switch, PTO EG1
				S31	B 7	Switch, PTO EK
				S164	B 3	Switch, PTO EG2
				S168	D 3	Switch, PTO ED
				S169	D 3	Switch, PTO ED2
				S170/S171	D 7	Switch, PTO AWD / split shaft

PTO EK

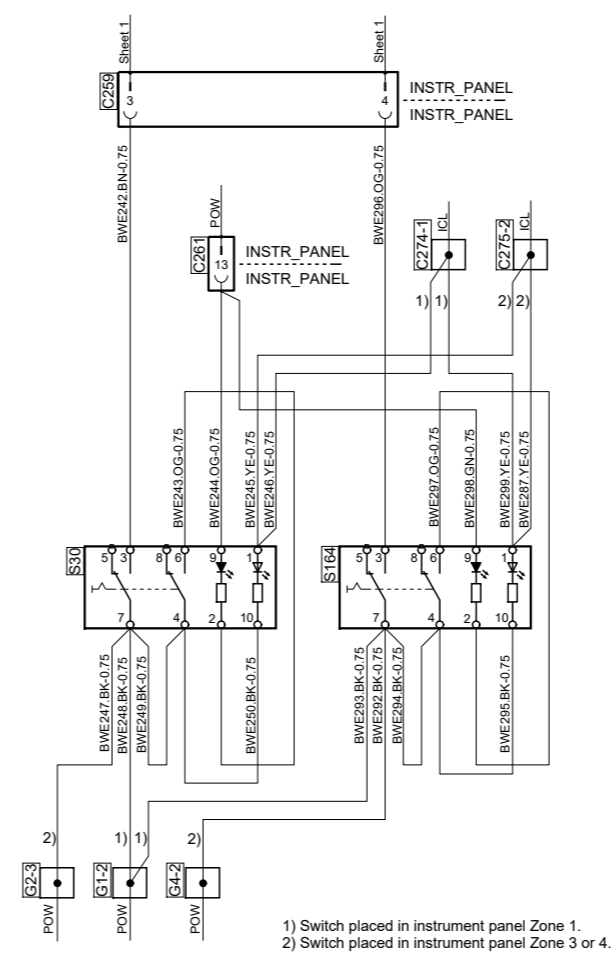

PTO EG



SCANIA

Circuit Diagram:

BWE

Drawing No.-
Sheet-Rev: **2063643-2-11**

N.B. The copyright and ownership of this drawing including associated computer data are and will remain ours. They must not be copied, used or brought to the attention of any third party without prior permission (C) Scania, Sweden