

PTO AWD / Split shaft

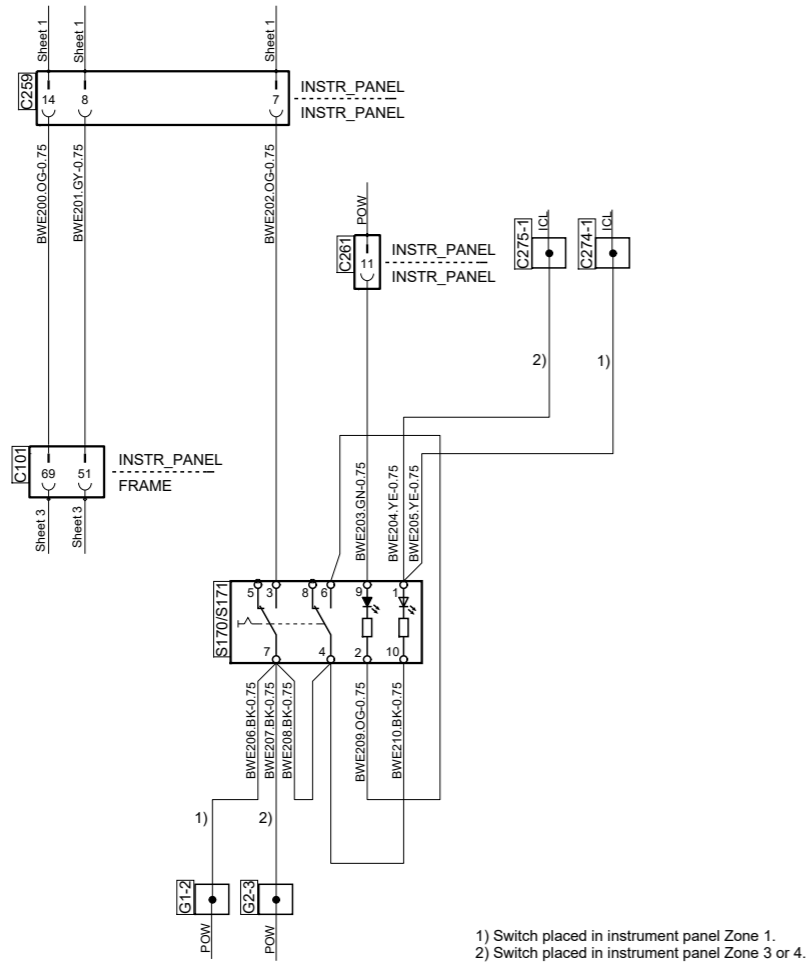

1) Switch placed in instrument panel Zone 1.
2) Switch placed in instrument panel Zone 3 or 4.

PTO ED

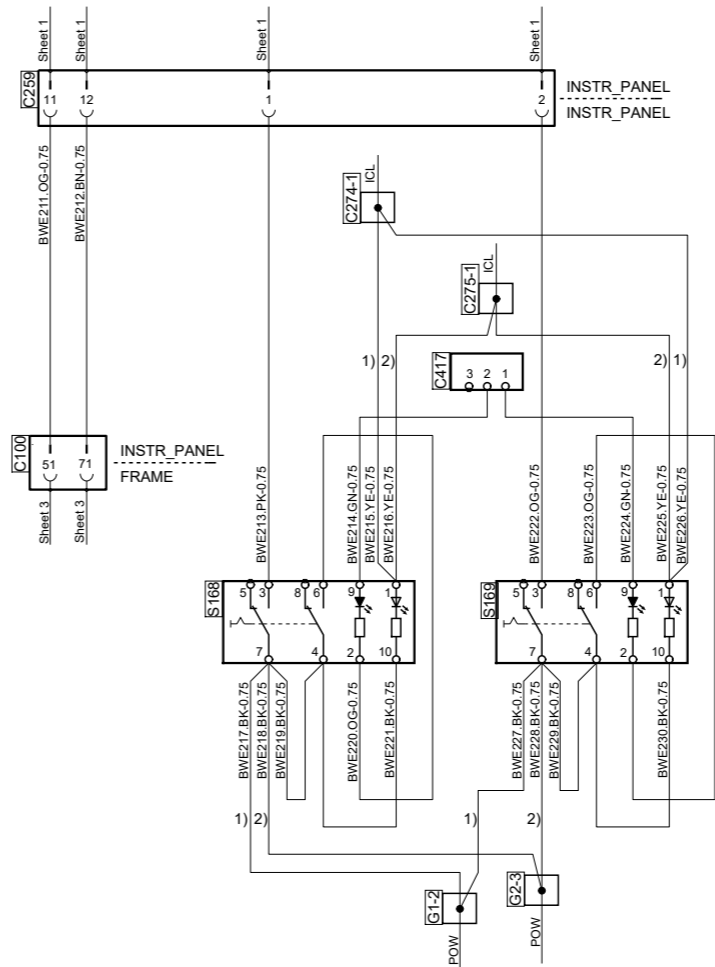

1) Switch placed in instrument panel Zone 1.
2) Switch placed in instrument panel Zone 3 or 4.

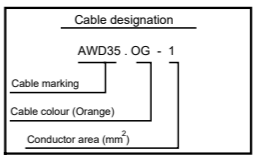

Code	Colour
BK	Black
BN	Brown
RD	Red
OG	Orange
YE	Yellow
GN	Green
BU	Blue
VT	Violet
GY	Grey
WH	White
PK	Pink

Des.	Pos.	Description
C100	E 4	Connector, 72-pole
C101	B 8	Connector, 72-pole
C101	E 8	Connector, 72-pole
C259	C 4	Connector, 21-pole
C259	C 8	Connector, 21-pole
C259	F 4	Connector, 21-pole
C259	F 8	Connector, 21-pole
C261	B 4	Connector, 21-pole
C261	B 7	Connector, 21-pole
C261	E 7	Connector, 21-pole
C274-1	F 6	Splice, instrument light
C275-1	F 6	Splice, instrument light
C275-2	C 3	Splice, instrument light
C417	E 3	Cut cable, BWE
G1-2	A 4	Splice, ground
G2-3	D 7	Splice, ground
G4-2	A 6	Splice, ground
S30	B 4	Switch, PTO EG1
S31	B 7	Switch, PTO EK
S164	B 3	Switch, PTO EG2
S168	D 3	Switch, PTO ED
S169	D 3	Switch, PTO ED2
S170/S171	D 7	Switch, PTO AWD / split shaft

PTO EK

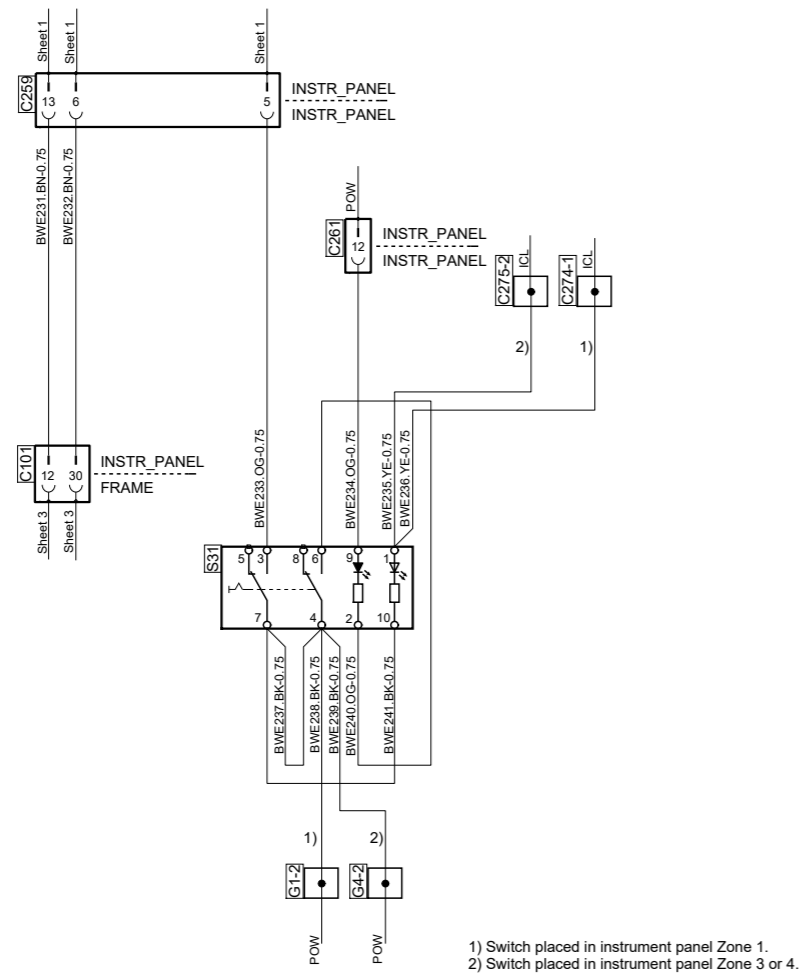

1) Switch placed in instrument panel Zone 1.
2) Switch placed in instrument panel Zone 3 or 4.

PTO EG

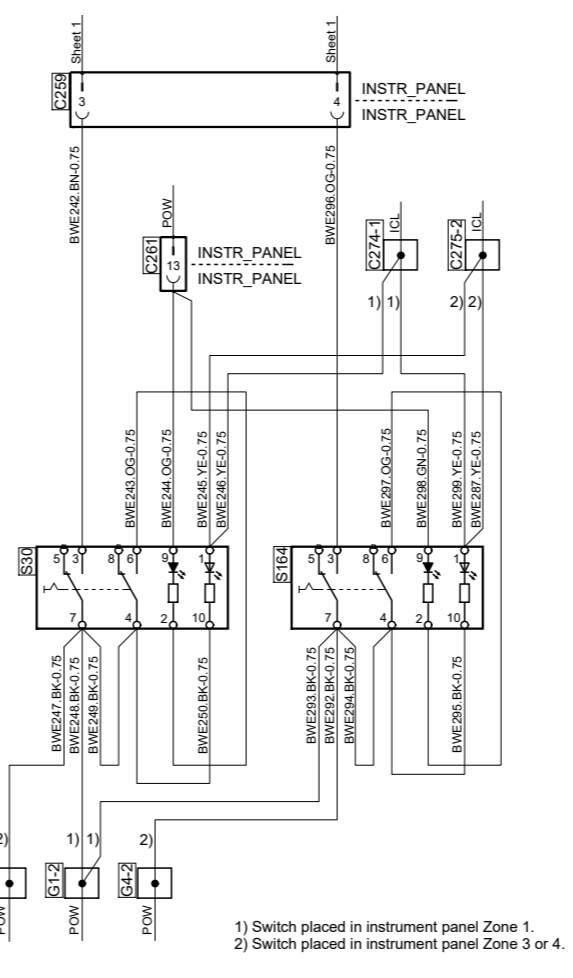

1) Switch placed in instrument panel Zone 1.
2) Switch placed in instrument panel Zone 3 or 4.



Circuit Diagram:
BWE

Drawing No.-
Sheet-Rev: **2063643-2-9**

N.B. The copyright and ownership of this drawing including associated computer data are and will remain ours. They must not be copied, used or brought to the attention of any third party without prior permission (C) Scania, Sweden