

TIPPER BODY WITHOUT TANK

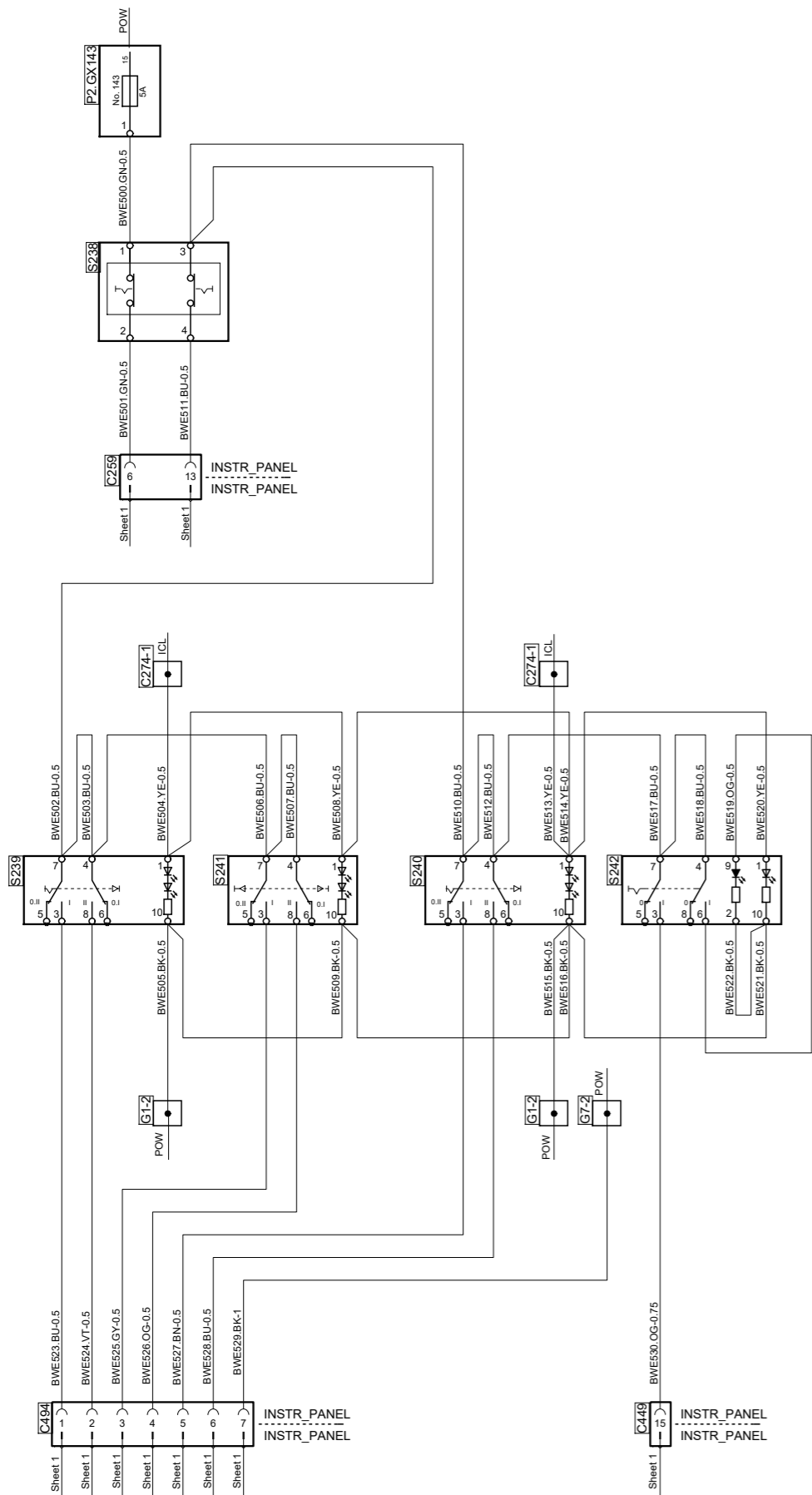

TIPPER BODY WITH TANK

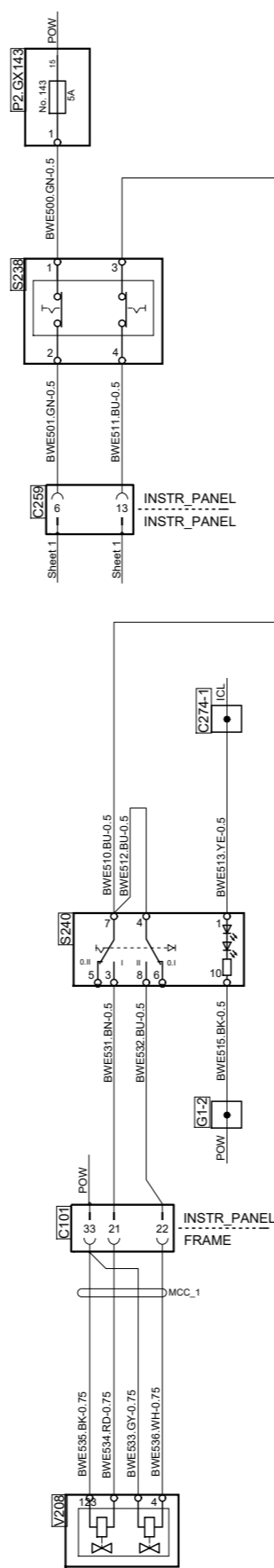

TIPPER BODY HEATING

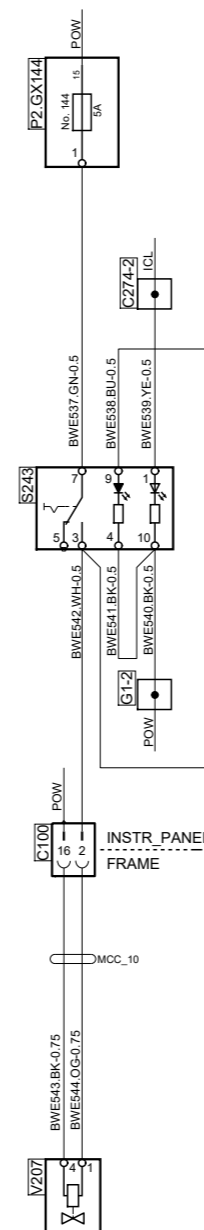

TIPPER BODY VIBRATOR

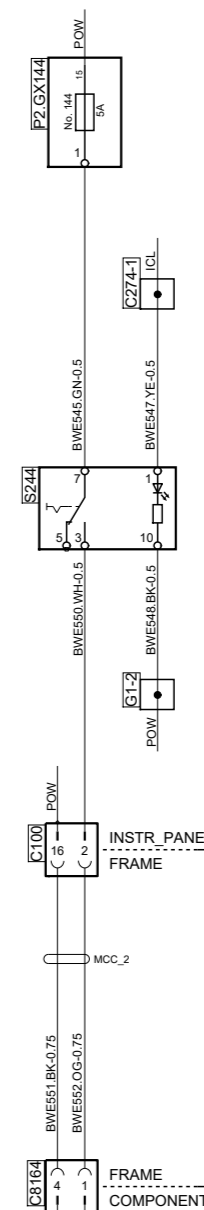

Cable designation

AWD35 OG - 1

Cable marking

Cable colour (Orange)

Conductor area (mm²)

Code	Colour
BK	Black
BN	Brown
RD	Red
OG	Orange
YE	Yellow
GN	Green
BU	Blue
VT	Violet
GY	Grey
WH	White
PK	Pink

Des.	Pos.	Description
C100	C 2	Connector, 72-pole
C100	C 3	Connector, 72-pole
C101	B 5	Connector, 72-pole
C259	D 5	Connector, 21-pole
C259	D	Connector, 21-pole
C274-1	D 8	Splice, instrument light
C274-2	E 3	Splice, instrument light
C449	A 6	Connector, 18-pole
C494	A 8	Connector, 21-pole
C8164	B 2	Connector, 4-pole
G1-2	B 8	Splice, ground
G7-2	B 6	Splice, ground
P2.GX143	F 5	Fuse socket, central electric unit
P2.GX143	F 8	Fuse socket, central electric unit
P2.GX144	E 2	Fuse socket, central electric unit
P2.GX144	E 3	Fuse socket, central electric unit
S238	E 5	Switch, emergency stop
S238	E 7	Switch, emergency stop
S239	C 8	Switch, tipper body, truck
S240	C 5	Switch, tipper body, trailer
S240	C 7	Switch, tipper body, trailer
S241	C 7	Switch, tipper hatch, truck
S242	C 6	Switch, tipper hatch, trailer
S243	D 3	Switch, tipper body heating
S244	D 2	Switch, tipper body, vibrator
V207	B 3	Solenoid valve, tipper body heating
V208	A 5	Solenoid valve, wet kit tank



Circuit Diagram:

BWE

Drawing No.-
Sheet-Rev: **2063643-5-3**

N.B. The copyright and ownership of this drawing including associated computer data are and will remain ours. They must not be copied, used or brought to the attention of any third party without prior permission (C) Scania, Sweden