

TIPPER BODY WITHOUT TANK

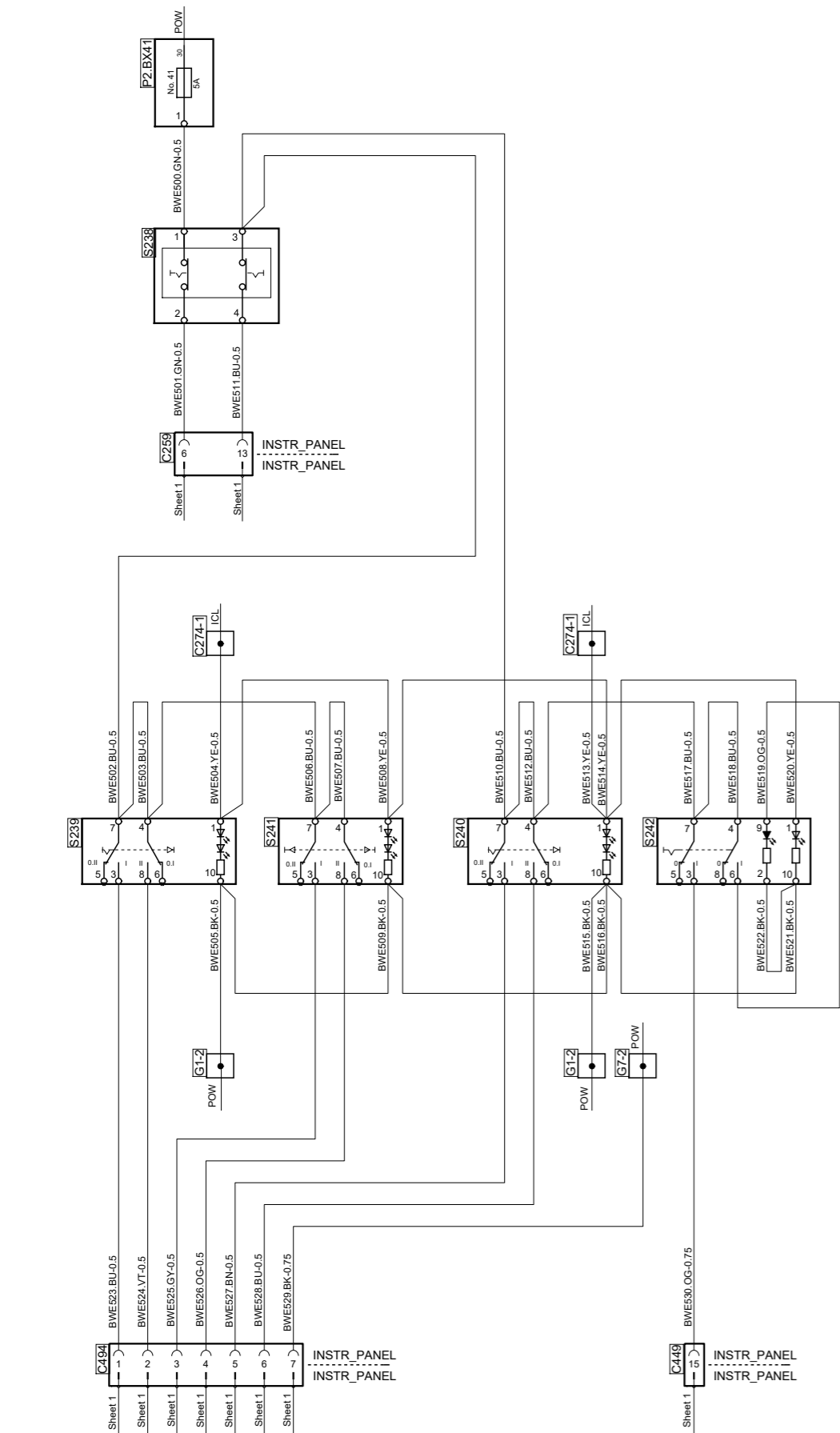

TIPPER BODY WITH TANK

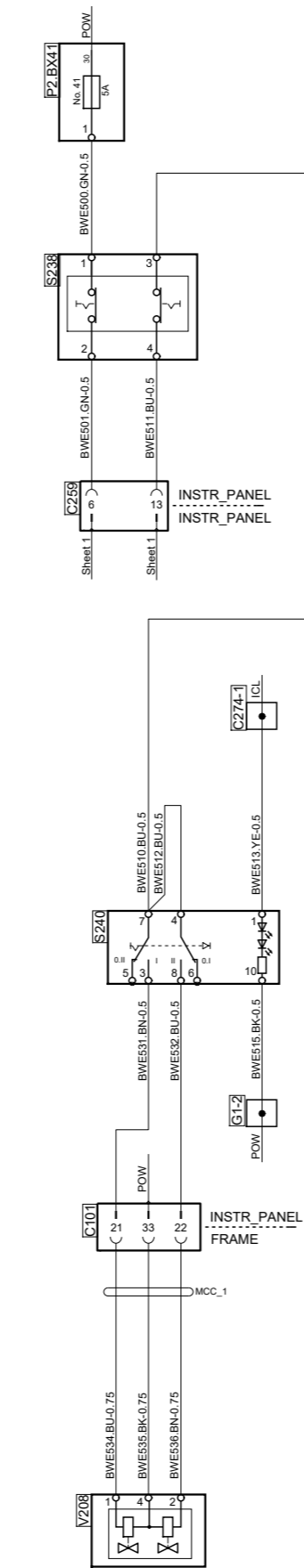

TIPPER BODY HEATING

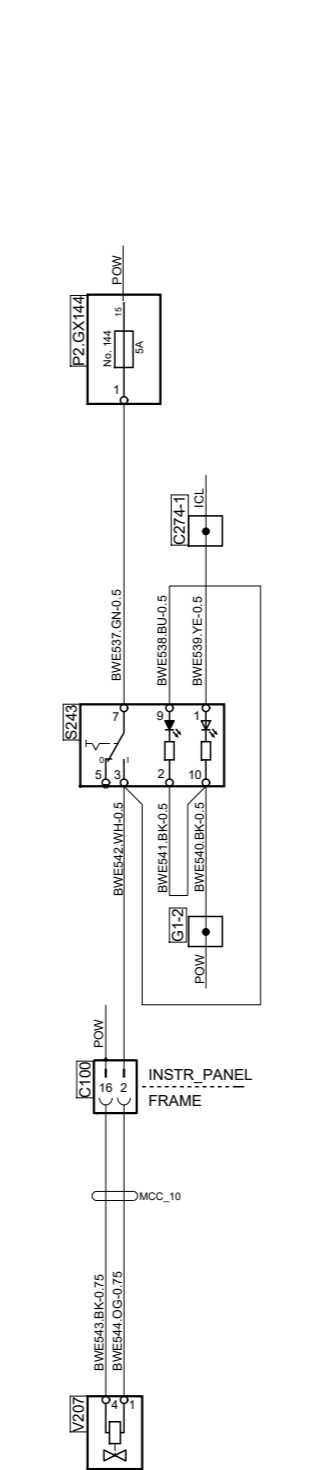

TIPPER BODY VIBRATOR

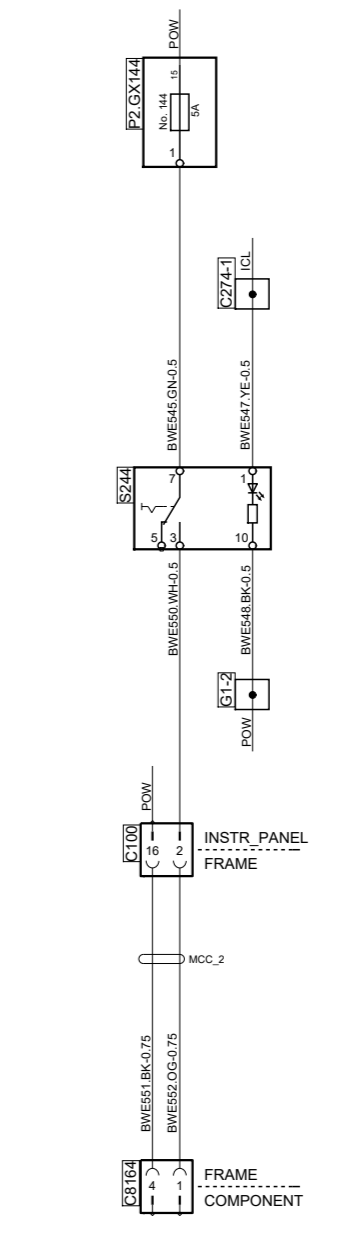

Cable designation

AWD35 OG - 1

Cable marking

Cable colour (Orange)

Conductor area (mm²)

Code	Colour	Des.	Pos.	Description
C100	Black	C100	C 2	Connector, 72-pole
C100	Black	C100	C 3	Connector, 72-pole
BK	Black	C101	B 5	Connector, 72-pole
BN	Brown	C259	D 5	Connector, 21-pole
RD	Red	C259	D 8	Connector, 21-pole
OG	Orange	C274-1	D 5	Splice, instrument light
YE	Yellow	C274-1	D 6	Splice, instrument light
GN	Green	C274-1	D 8	Splice, instrument light
BU	Blue	C274-1	E 2	Splice, instrument light
VT	Violet	C274-1	E 3	Splice, instrument light
GY	Grey	C449	A 6	Connector, 18-pole
WH	White	C494	A 8	Connector, 21-pole
PK	Pink	C8164	B 2	Connector, 4-pole
G1-2	B 5	G1-2	B 6	Splice, ground
G1-2	B 8	G1-2	B 8	Splice, ground
G1-2	D 2	G1-2	D 2	Splice, ground
G1-2	D 2	G1-2	D 2	Splice, ground
G7-2	B 6	G7-2	B 6	Splice, ground
P2.BX41	F 5	P2.BX41	F 5	Fuse socket, central electric unit
P2.BX41	F 8	P2.BX41	F 8	Fuse socket, central electric unit
P2.GX144	E 2	P2.GX144	E 2	Fuse socket, central electric unit
P2.GX144	E 3	P2.GX144	E 3	Fuse socket, central electric unit
S238	E 5	S238	E 5	Switch, emergency stop
S238	E 7	S238	E 7	Switch, emergency stop
S239	C 8	S239	C 8	Switch, tipper body, truck
S240	C 5	S240	C 5	Switch, tipper body, trailer
S240	C 7	S240	C 7	Switch, tipper body, trailer
S241	C 7	S241	C 7	Switch, tipper hatch, truck
S242	C 6	S242	C 6	Switch, tipper hatch, trailer
S243	D 3	S243	D 3	Switch, tipper body heating
S244	D 2	S244	D 2	Switch, tipper body, vibrator
V207	B 3	V207	B 3	Solenoid valve, tipper body heating
V208	A 5	V208	A 5	Solenoid valve, wet kit tank



Circuit Diagram:

BWE

Drawing No.- 2063643-5-6
Sheet-Rev.

N.B. The copyright and ownership of this drawing including associated computer data are and will remain ours. They must not be copied, used or brought to the attention of any third party without prior permission (C) Scania, Sweden