

TIPPER BODY WITHOUT TANK

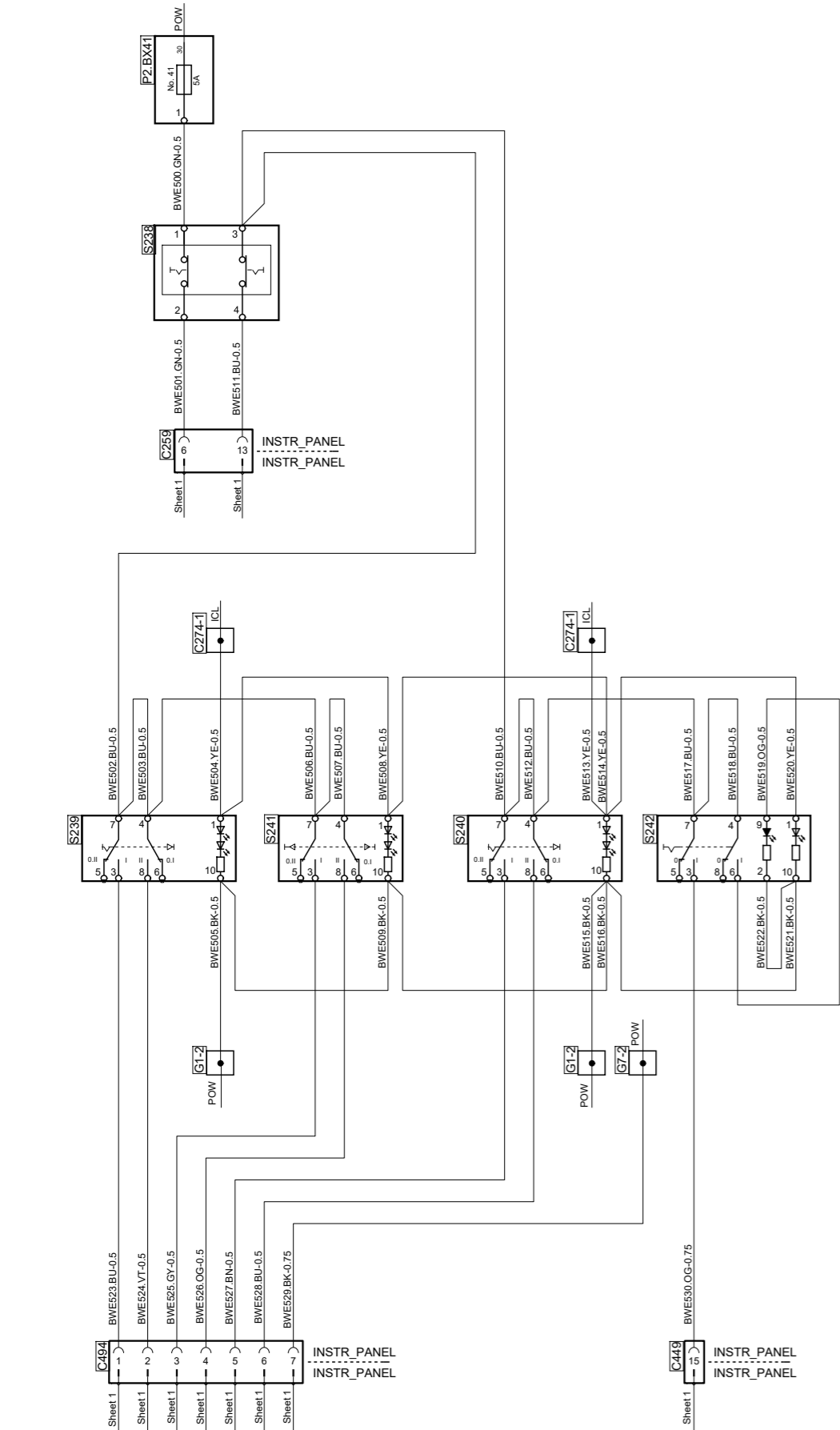

TIPPER BODY WITH TANK

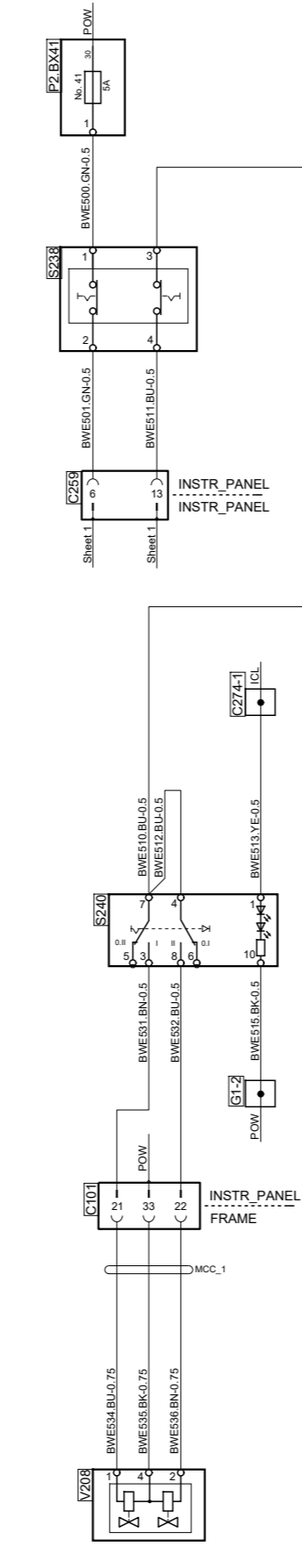

TIPPER BODY HEATING

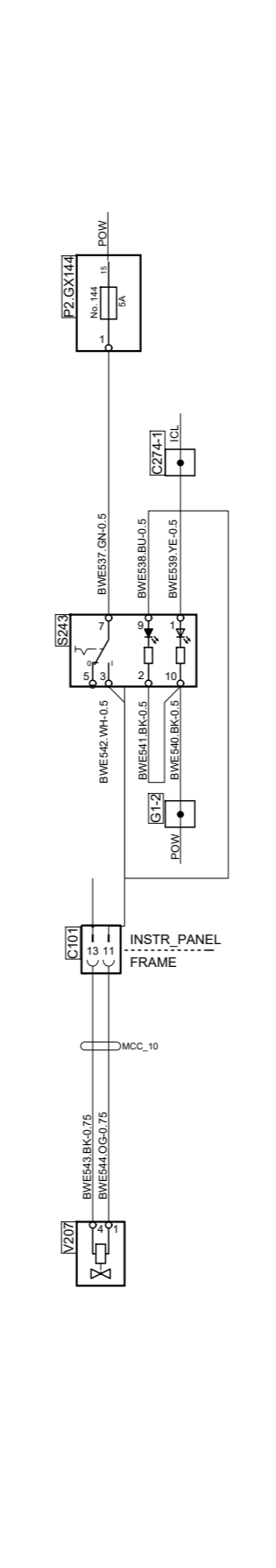

TIPPER BODY VIBRATOR

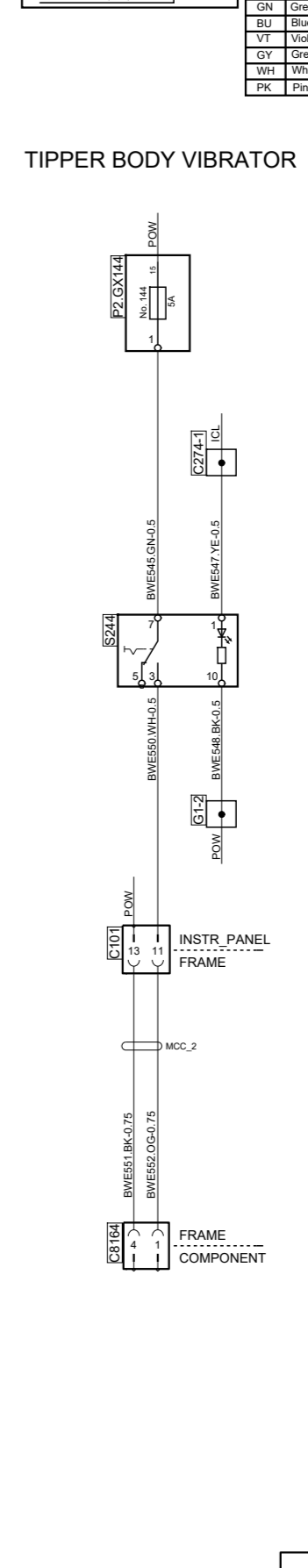

Cable designation

AWD35 OG - 1

Cable marking

Cable colour (Orange)

Conductor area (mm<sup>2</sup>)

Code	Colour	Des.	Pos.	Description
BK	Black	C101	B 5	Connector, 72-pole
BN	Brown	C101	C 2	Connector, 72-pole
RD	Red	C101	C 3	Connector, 72-pole
OG	Orange	C259	D 5	Connector, 21-pole
YE	Yellow	C274-1	D 5	Splice, instrument light
GN	Green	C274-1	D 6	Splice, instrument light
BU	Blue	C274-1	D 8	Splice, instrument light
VT	Violet	C274-1	E 2	Splice, instrument light
GY	Grey	C274-1	E 3	Splice, instrument light
WH	White	C494	A 6	Connector, 18-pole
PK	Pink	C494	A 8	Connector, 21-pole
		C8164	B 2	Connector, 4-pole
		G1-2	B 5	Splice, ground
		G1-2	B 6	Splice, ground
		G1-2	B 8	Splice, ground
		G1-2	D 2	Splice, ground
		G1-2	D 2	Splice, ground
		G7-2	B 6	Splice, ground
		P2.BX41	F 5	Fuse socket, central electric unit
		P2.BX41	F 8	Fuse socket, central electric unit
		P2.GX144	E 2	Fuse socket, central electric unit
		P2.GX144	E 3	Fuse socket, central electric unit
		S238	E 5	Switch, emergency stop
		S239	E 7	Switch, emergency stop
		S240	C 5	Switch, tipper body, trailer
		S240	C 7	Switch, tipper body, trailer
		S241	C 7	Switch, tipper hatch, truck
		S242	C 6	Switch, tipper hatch, trailer
		S243	D 3	Switch, tipper body heating
		S244	D 2	Switch, tipper body, vibrator
		V207	B 3	Solenoid valve, tipper body heating
		V208	A 5	Solenoid valve, wet kit tank



Circuit Diagram:

**BWE**

Drawing No.- 2063643-5-9  
Sheet-Rev:

N.B. The copyright and ownership of this drawing including associated computer data are and will remain ours. They must not be copied, used or brought to the attention of any third party without prior permission (C) Scania, Sweden