

Control Inverter

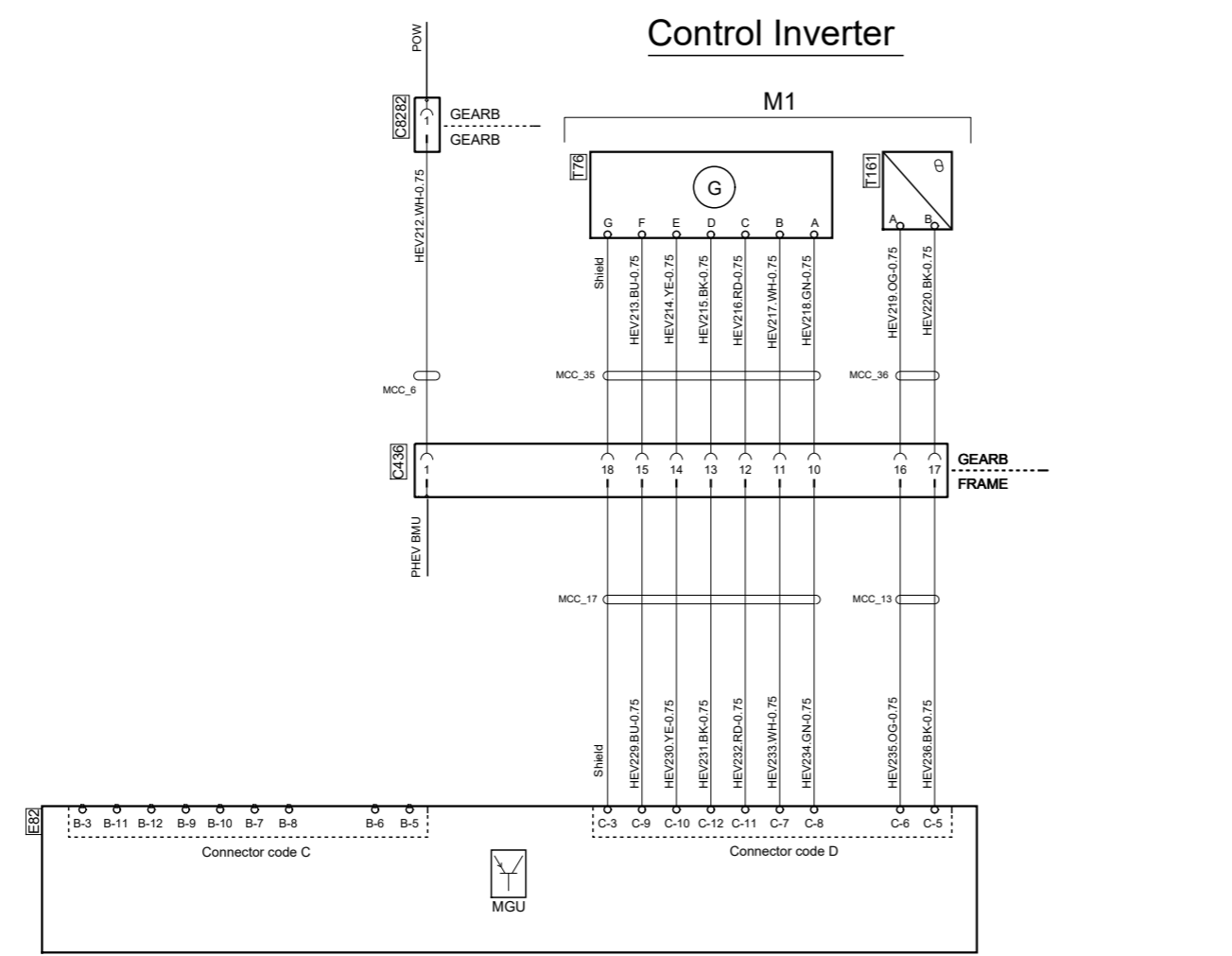

Refrigerant Compressor

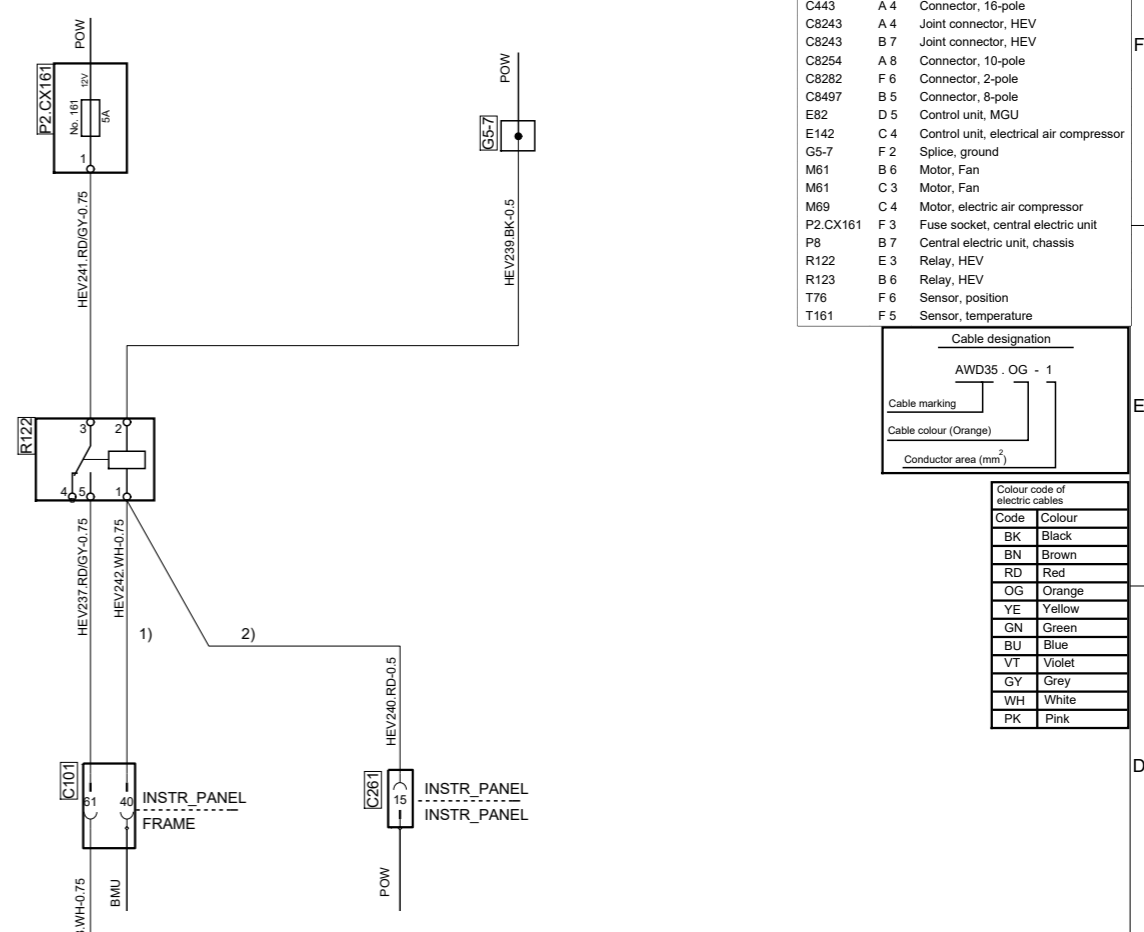

Des.	Pos.	Description
C101	D 3	Connector, 72-pole
C193	C 8	Connector, 16-pole
C261	D 2	Connector, 21-pole
C436	E 6	Connector, 18-pole
C443	A 4	Connector, 16-pole
C8243	A 4	Joint connector, HEV
C8243	B 7	Joint connector, HEV
C8254	A 8	Connector, 10-pole
C8282	F 6	Connector, 2-pole
C8497	B 5	Connector, 8-pole
E82	D 5	Control unit, MGU
E142	C 4	Control unit, electrical air compressor
G5-7	F 2	Splice, ground
M61	B 6	Motor, Fan
M61	C 3	Motor, Fan
M69	C 4	Motor, electric air compressor
P2.CX161	F 3	Fuse socket, central electric unit
P8	B 7	Central electric unit, chassis
R122	E 3	Relay, HEV
R123	B 6	Relay, HEV
T76	F 6	Sensor, position
T161	F 5	Sensor, temperature

Cable designation	
AWD35	OG - 1
Cable marking	
Cable colour (Orange)	
Conductor area (mm ²)	

Colour code of electric cables	
Code	Colour
BK	Black
BN	Brown
RD	Red
OG	Orange
YE	Yellow
GN	Green
BU	Blue
VT	Violet
GY	Grey
WH	White
PK	Pink

Note: For P80Gen2, E82.C (Machine2 reference in MGU) will be connected to M1 due to cable harness installation reasons.

Gearbox interface

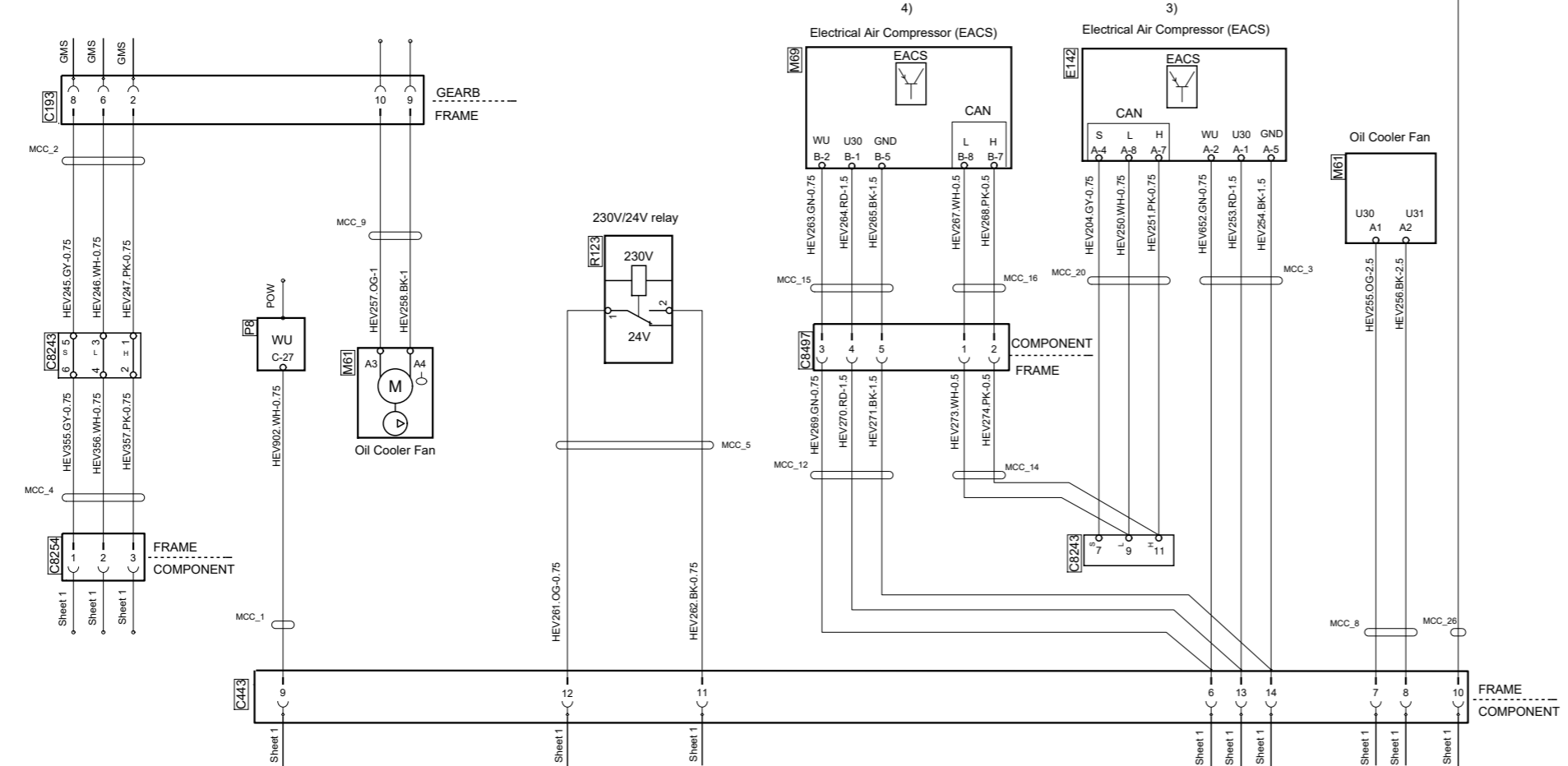

- Notes
- 1) PHEV
 - 2) HEV
 - 3) EACS1
 - 4) EACS2



Circuit Diagram:
HEV

Drawing No.- 2555000-2-23
Sheet-Rev:

N.B. The copyright and ownership of this drawing including associated computer data are and will remain ours. They must not be copied, used or brought to the attention of any third party without prior permission (C) Scania, Sweden

VCA