

Des.	Pos.	Description
C6411	E 5	Splice, 1-pole
C6416	E 7	Splice, 1-pole
C6418	E 7	Splice, 1-pole
C6422	C 6	Connector, 3-pole
C6429	E 6	Splice, 1-pole
E6047	F 5	Control unit, Expansion unit J, MBS
G6400	D 7	Ground, 1-pole
L6000	D 7	Direct Interior light 2nd circuit right
L6000.B	D 4	Direct Interior light 2nd circuit right
L6001	D 6	Direct Interior light 2nd circuit left
L6124	D 6	Indirect Interior light 2nd circuit right
L6124 B	D 3	Indirect Interior light 2nd circuit right
L6125	D 5	Indirect Interior light 2nd circuit left

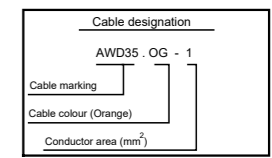

Colour code of electric cables

Code	Colour
BK	Black
BN	Brown
RD	Red
OG	Orange
GN	Green
BU	Blue
VT	Violet
GY	Grey
WH	White
PK	Pink

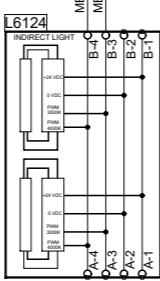
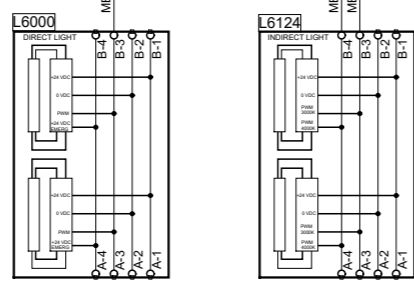
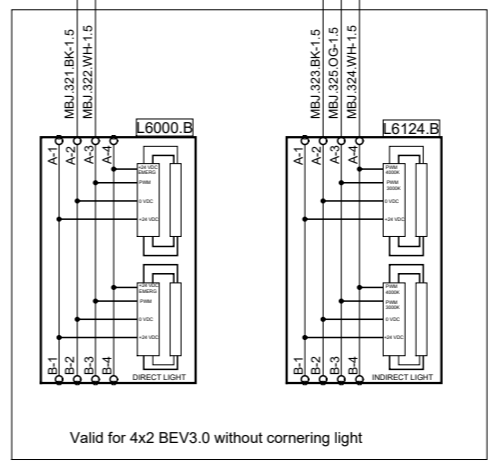
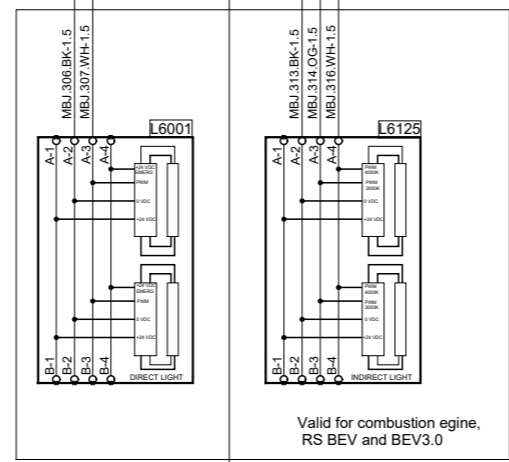
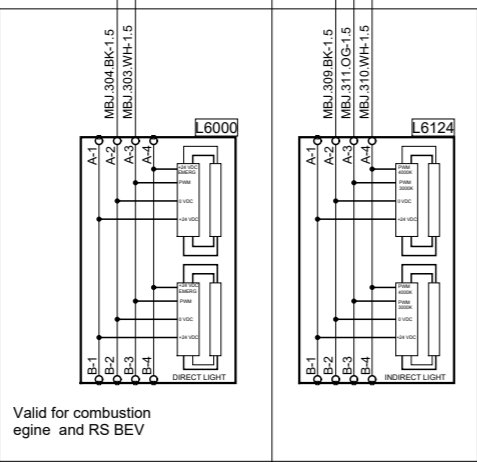
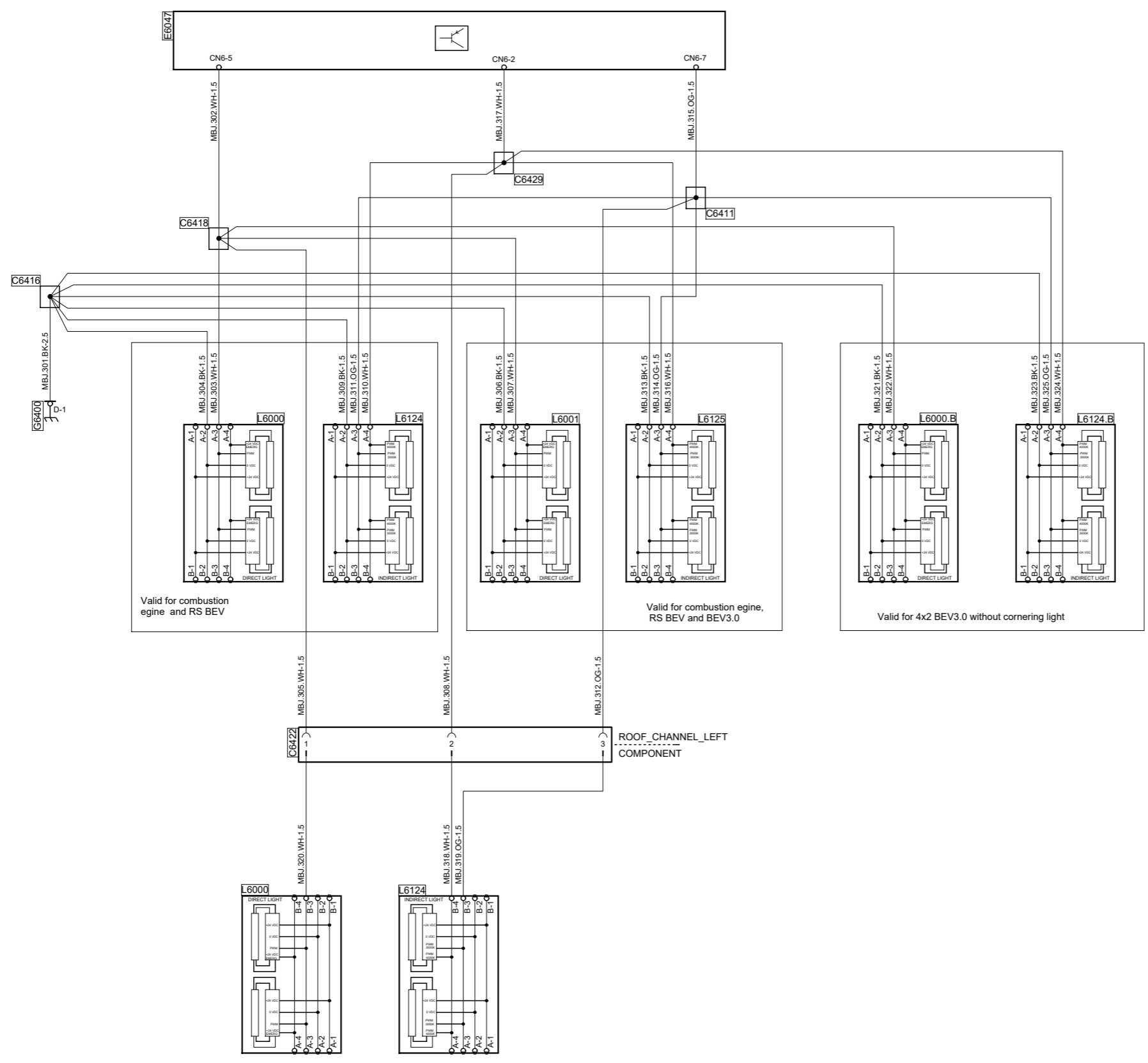

See sheet 1

SCANIA

Circuit Diagram:

MBS Node J

Drawing No.- 2710712-3-6
Sheet-Rev.

N.B. The copyright and ownership of this drawing including associated computer data are and will remain ours. They must not be copied, used or brought to the attention of any third party without prior permission (C) Scania, Sweden