

# LUBRICATION SYSTEM Overview

## Industrial and marine engines with cylinder block generation 3

The lubrication system is an important component in the engine. The oil lubricates, cools and drives other components. The oil pump is driven by the timing gear via a shaft. The oil is drawn from the oil sump via a suction pipe. The oil pump creates the flow and pressure that supplies the system with oil. Under normal conditions and operating temperature, the flow in the system varies between approx. 72 and 160 l/min at 600-2100 rpm. Depending on the design of the oil pump, the oil flow is controlled either by a built in pressure control valve or by a solenoid valve mounted on the block. In most cases, the lubricating oil is returned by being allowed to freely flow back to the oil sump via ports. The level and temperature sensor gives the engine system ongoing information about the lubricating oil temperature. The oil level is checked when starting the engine. The oil pressure is constantly monitored by the engine control unit via the oil pressure sensor.

This overview shows the lubrication system from the oil sump to the cylinder block and cylinder head. The individual components are shown in detail on the subsequent pages.

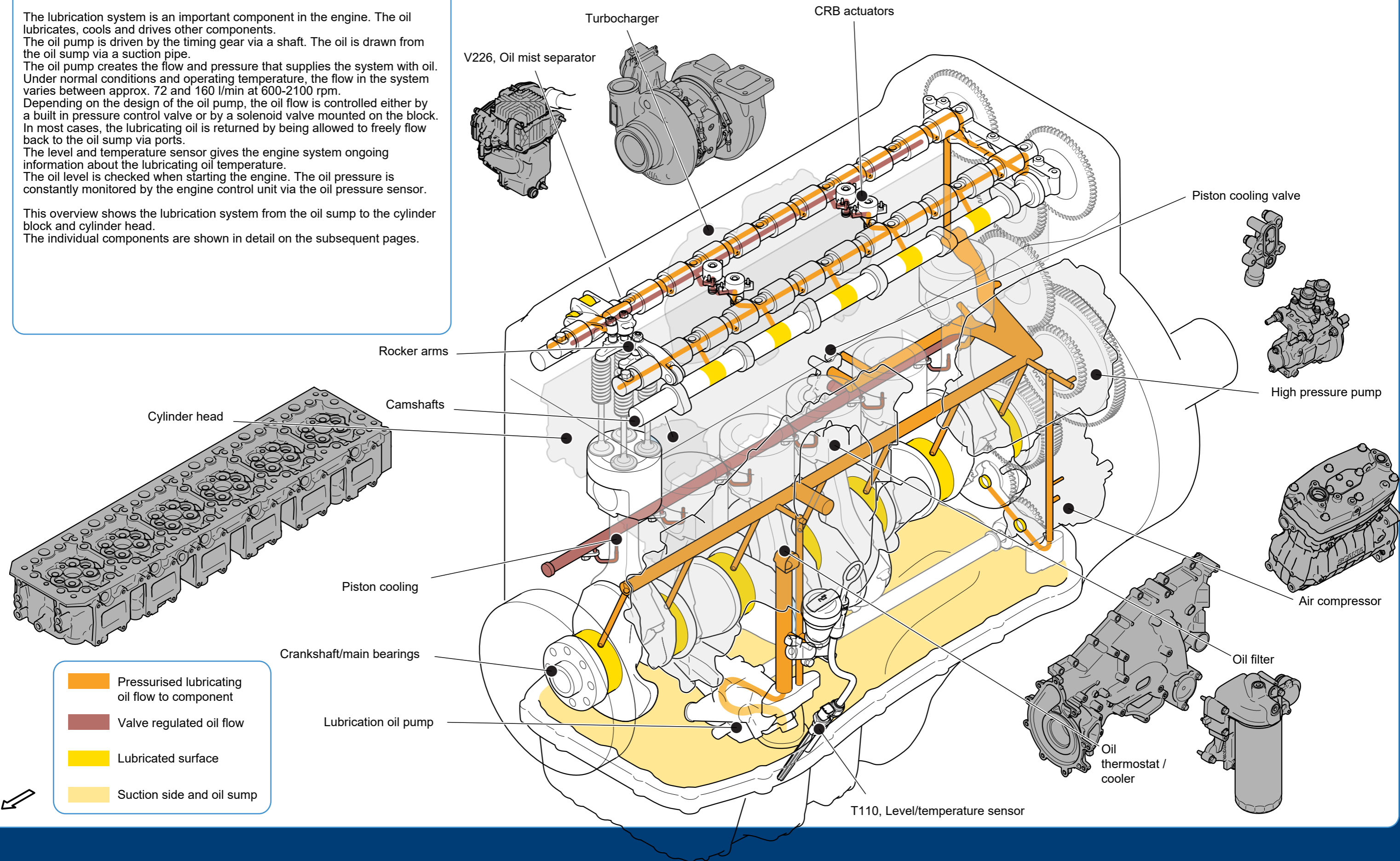

- Pressurised lubricating oil flow to component
- Valve regulated oil flow
- Lubricated surface
- Suction side and oil sump

# LUBRICATION SYSTEM High pressure pump and air compressor

## Industrial and marine engines with cylinder block generation 3



01:20-03 Issue 1 en-GB  
© Scania CV AB 2024, Sweden

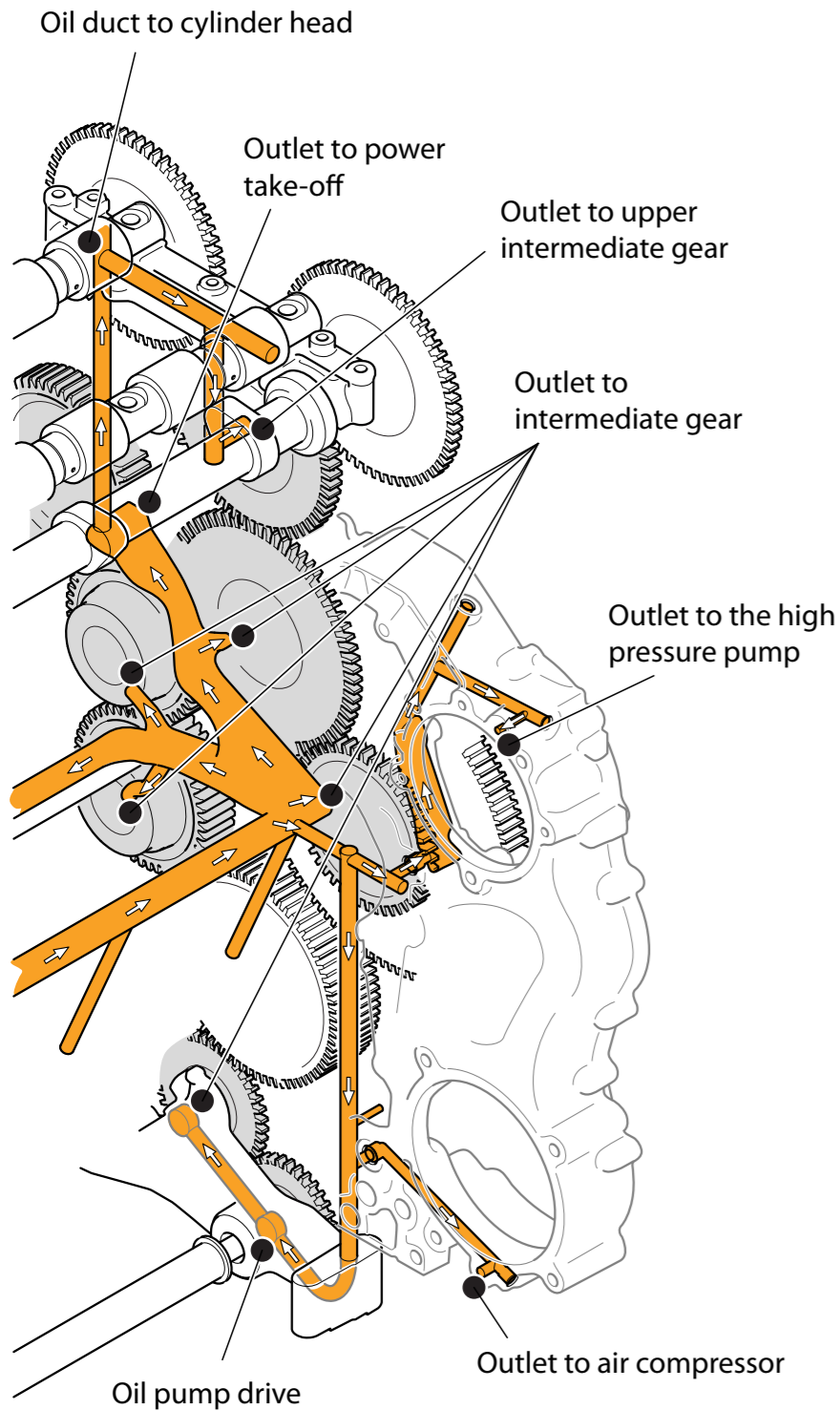

### High pressure pump (oil lubricated)

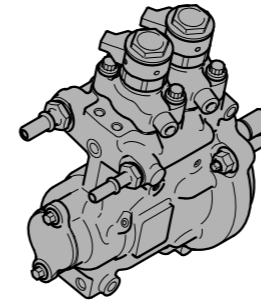

The oil-lubricated high pressure pump is driven by the engine crankshaft via the gear transmission. The lubricating oil flows from the oil gallery in the cylinder block to the high pressure pump via an oil duct in the timing gear casing. The lubricating oil is returned back to the rear crankshaft bearing and the pistons in the pump housing via ports. Once pistons, cams, other components and surfaces are lubricated, the oil collects in the bottom of the pump housing. The oil runs back to the oil sump from the high pressure pump via the timing gear casing. The flow (depending on rpm) to the high pressure pump is approx. 2-8 l/min.

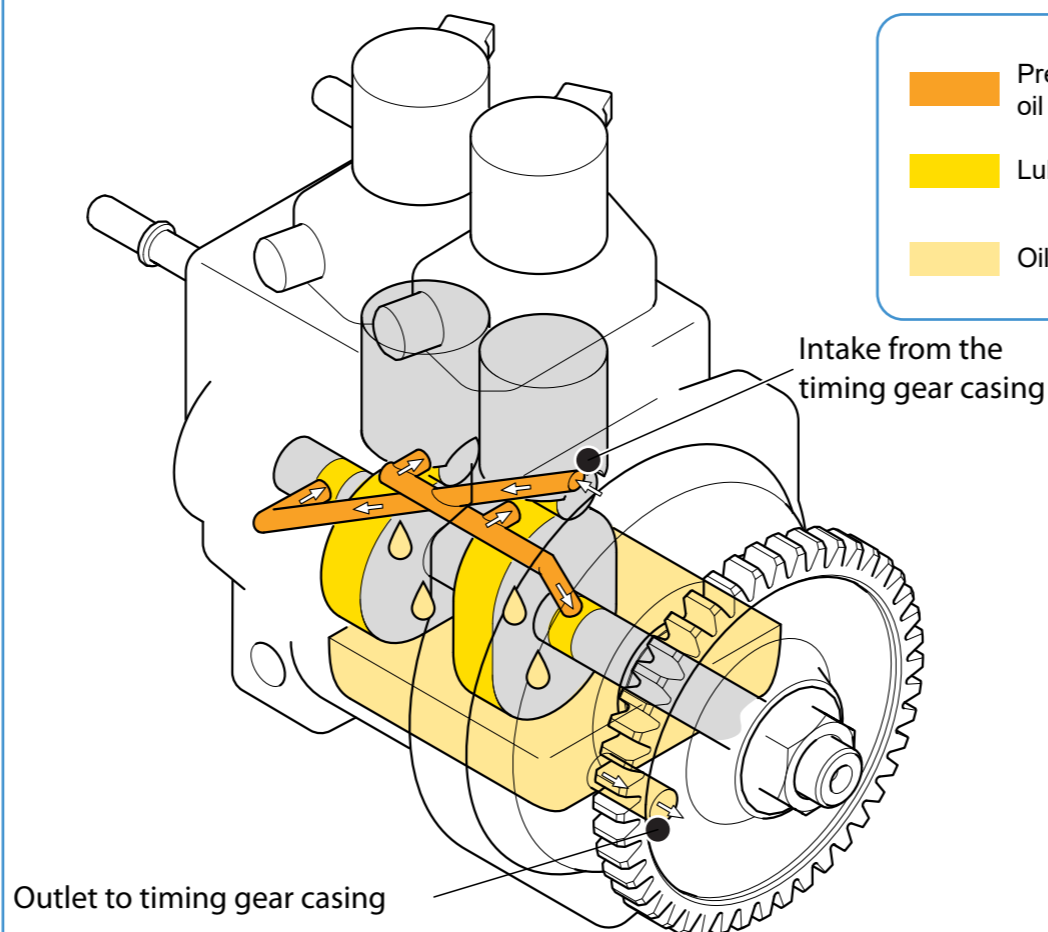

- Pressurised lubricating oil flow to component
- Lubricated surface
- Oil sump

### Air compressor

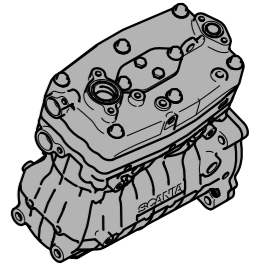

The air compressor is driven via a gear wheel in the engine timing gear. The air compressor is fluid-filled and connected to the engine cooling system. The air compressor is lubricated via the engine lubrication system. The lubricating oil flows from the oil gallery in the cylinder block to the air compressor via an oil duct in the timing gear casing. The crankshaft bearing is lubricated via ports in the crankshaft. After the rear crankshaft bearing, the lubricating oil runs down into the compressor housing and uses the crankshaft motion to splash lubricate other surfaces and components. The lubricating oil is drained via an opening in the air compressor to the timing gear casing where the lubricating oil runs down to the oil sump. The flow (depending on rotational speed) to the air compressor is approx. 3-6 l/min.

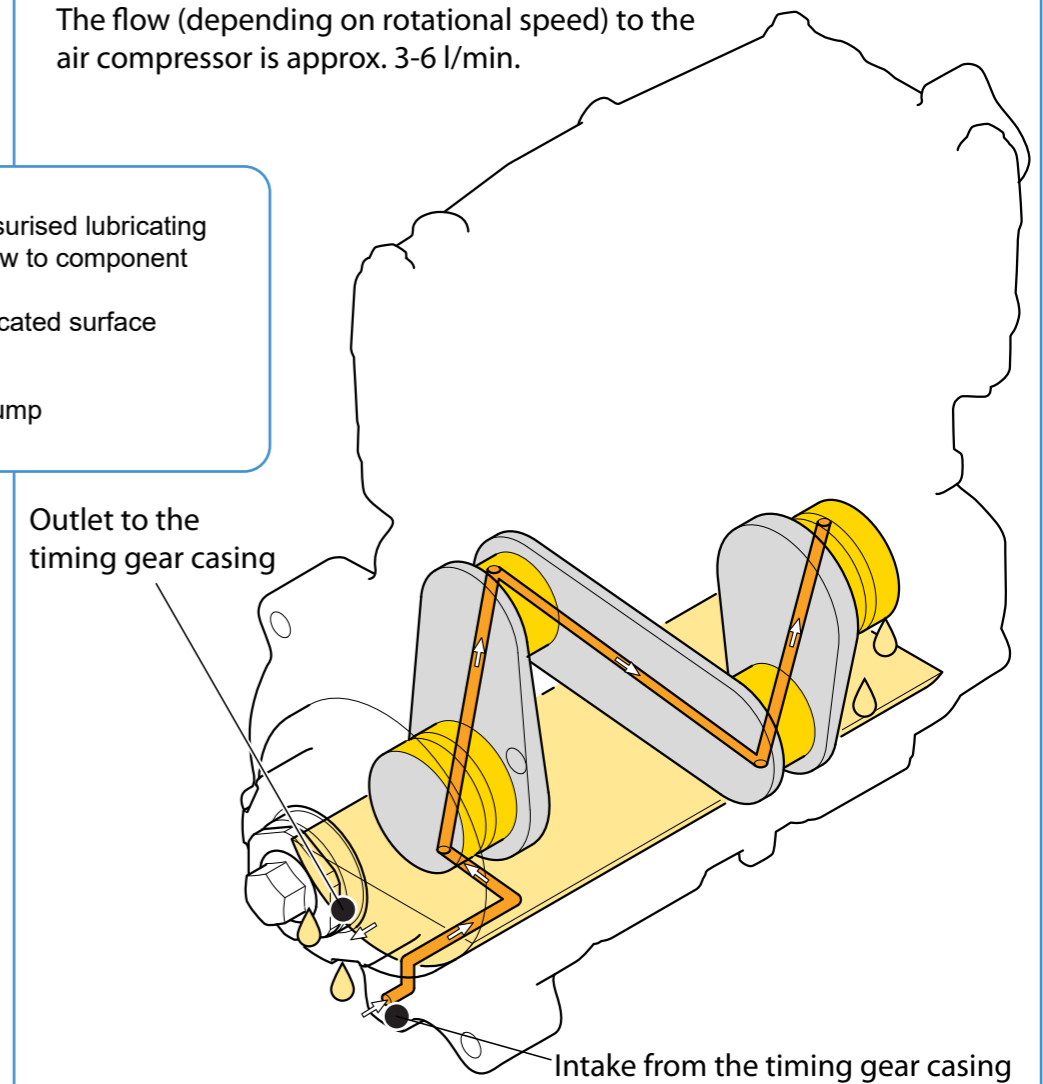

# LUBRICATION SYSTEM Oil cooler, oil thermostat and oil pump

## Industrial and marine engines with cylinder block generation 3

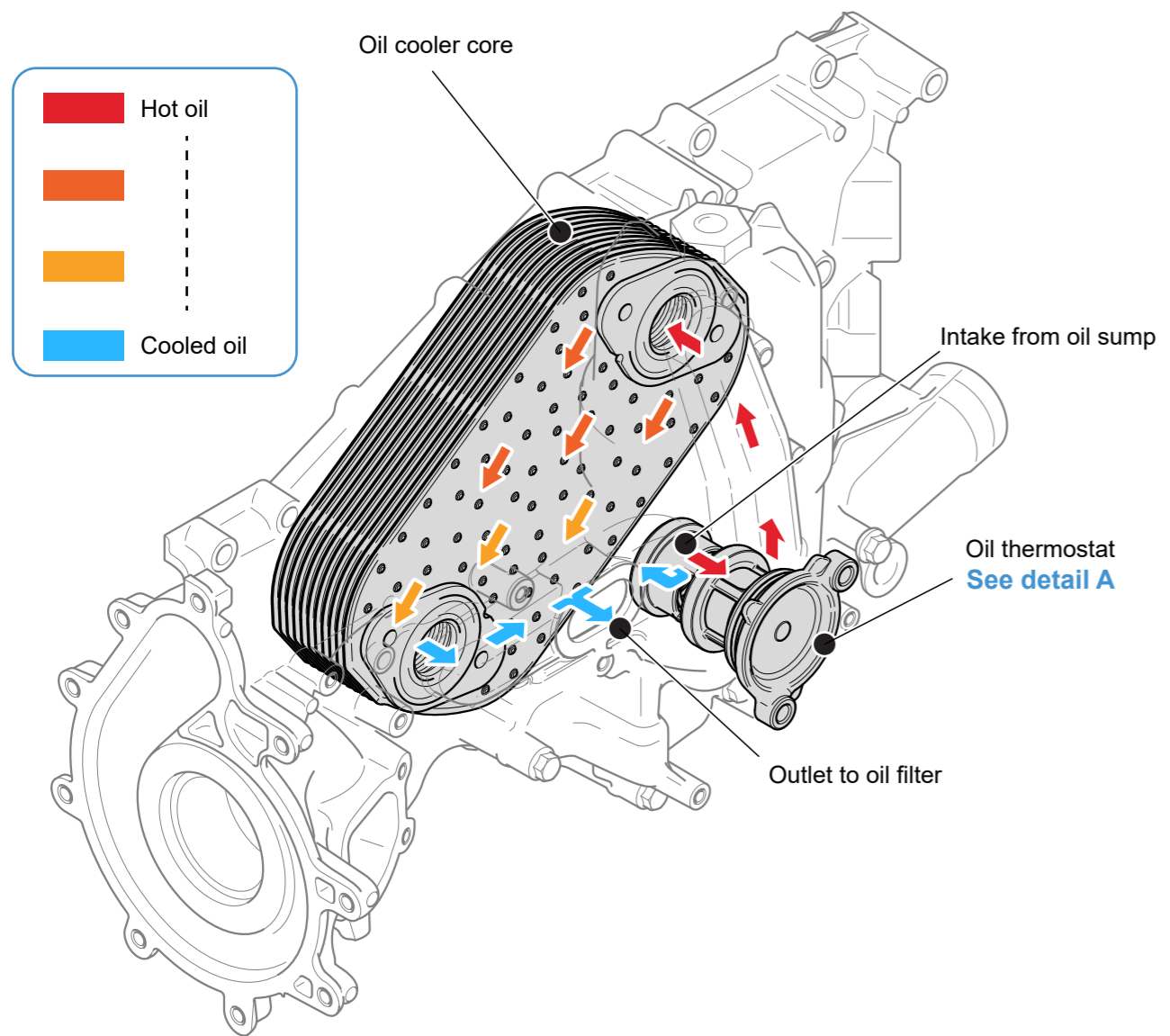

### Oil thermostat

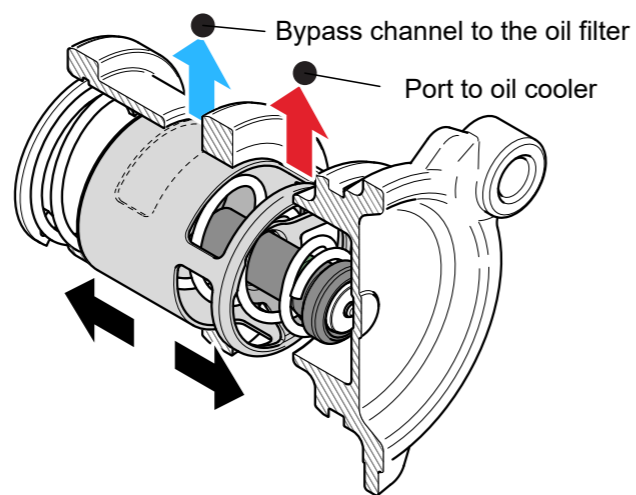

Temperature < 93°C: All oil goes directly to the oil filter via the bypass port

93-105 °C: The oil is distributed between the bypass channel and the oil cooler depending on the temperature; the higher the temperature, the more oil goes to the oil cooler

Temperature > 105°C: All oil flows to the oil filter via the oil cooler

### Pilot-controlled oil pump

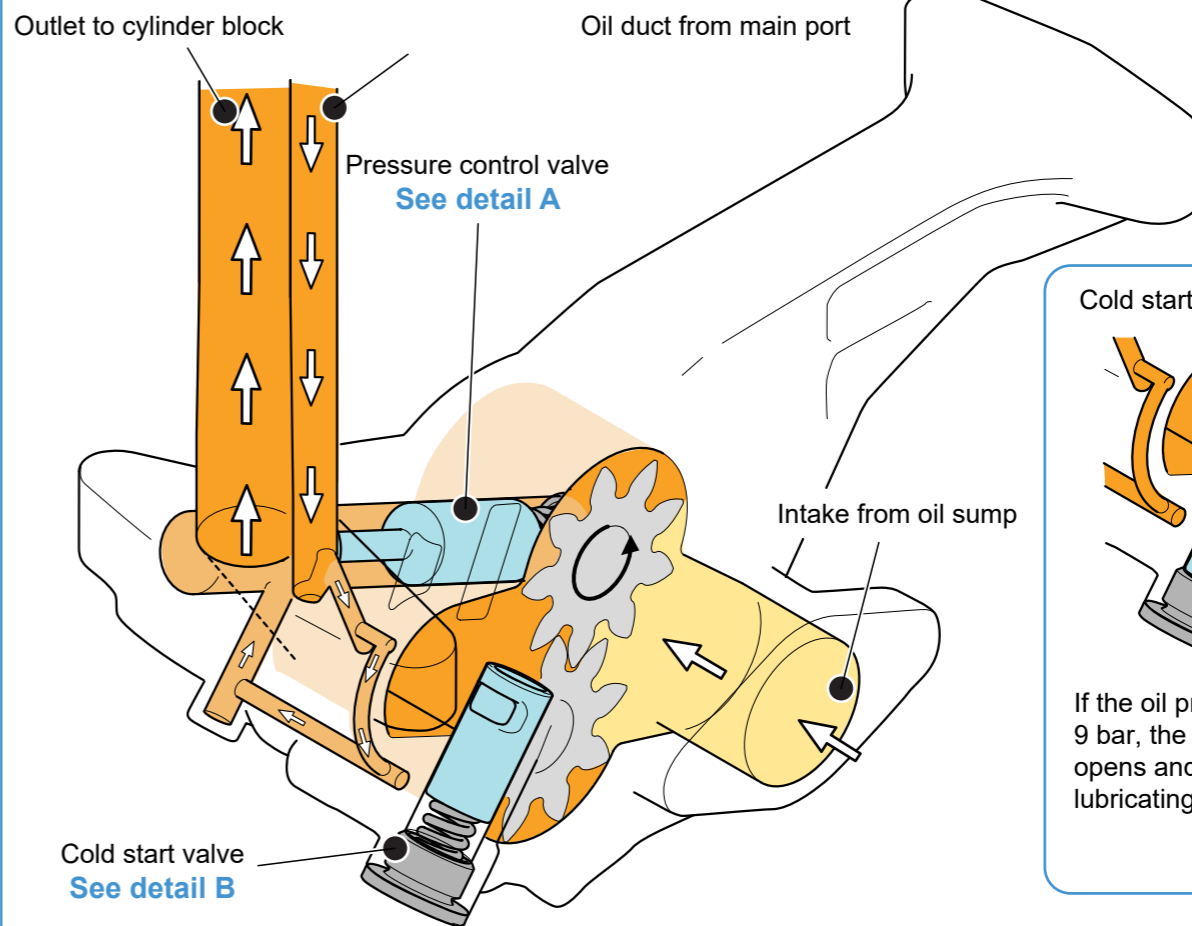

### Cold start valve Detail B



If the oil pressure exceeds 9 bar, the cold start valve opens and feeds excess lubricating oil to the oil sump.

- Pressurised lubricating oil flow to component
- Lubricating oil from the oil sump

The oil pump is driven via a shaft by the timing gear.

### Pressure control valve closed Detail A

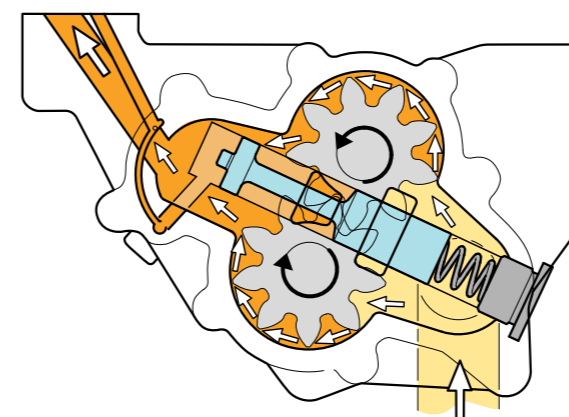

### Pressure control valve open Detail A

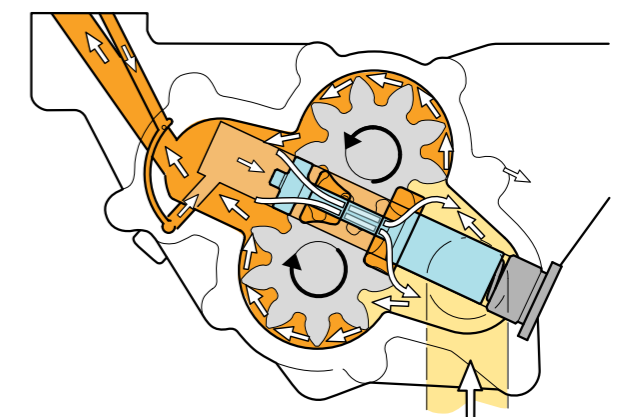

# LUBRICATION SYSTEM Valve components and compression

## release brake

### Industrial and marine engines with cylinder block generation 3

The camshaft frame is located on top of the cylinder head. The camshaft frame contains camshafts, rocker arm shafts and valve components. The lubricating oil comes up via a port in the cylinder head. From there, the oil flows out into the rocker arm shafts and from the rocker arm shafts to other components for lubrication. The compression release brake uses the oil to control the flow of oil to the compression release brake rocker arms using solenoid valves, thus braking the vehicle.

Rocker arm, exhaust valve

Detail B

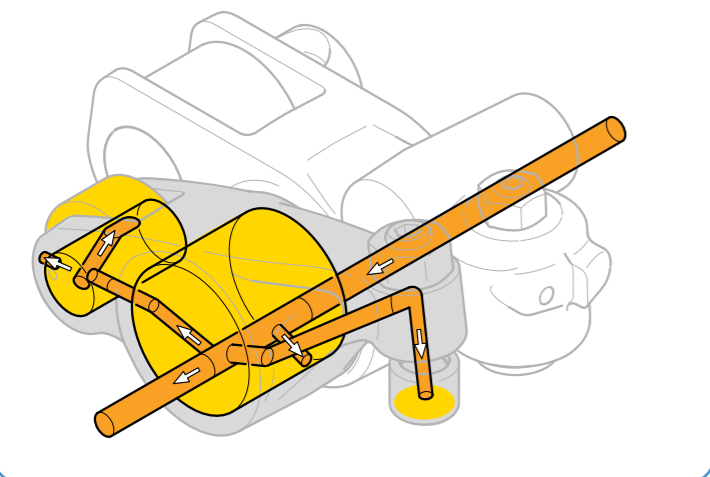

Rocker arm, compression release brake

Detail A

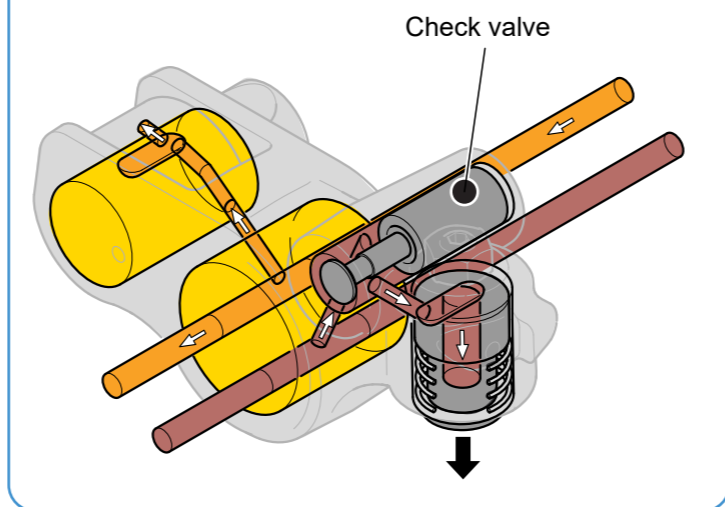

Rocker arm, compression release brake  
See detail A

Rocker arm, exhaust valve  
See detail B

Exhaust camshaft

Exhaust valve rocker arm shaft

Rocker arm, intake valve

Detail C

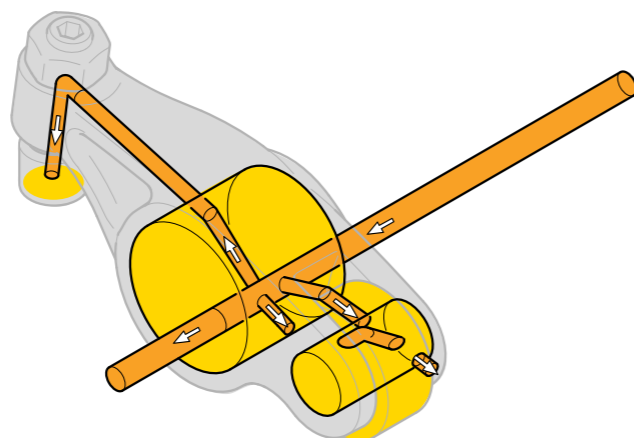

Intake valve rocker arm shaft

Rocker arm, intake valve  
See detail C

Intake camshaft

V233, Solenoid valve

V232, Solenoid valve

Oil duct in the cylinder head

V224, Solenoid valve

V223, Solenoid valve

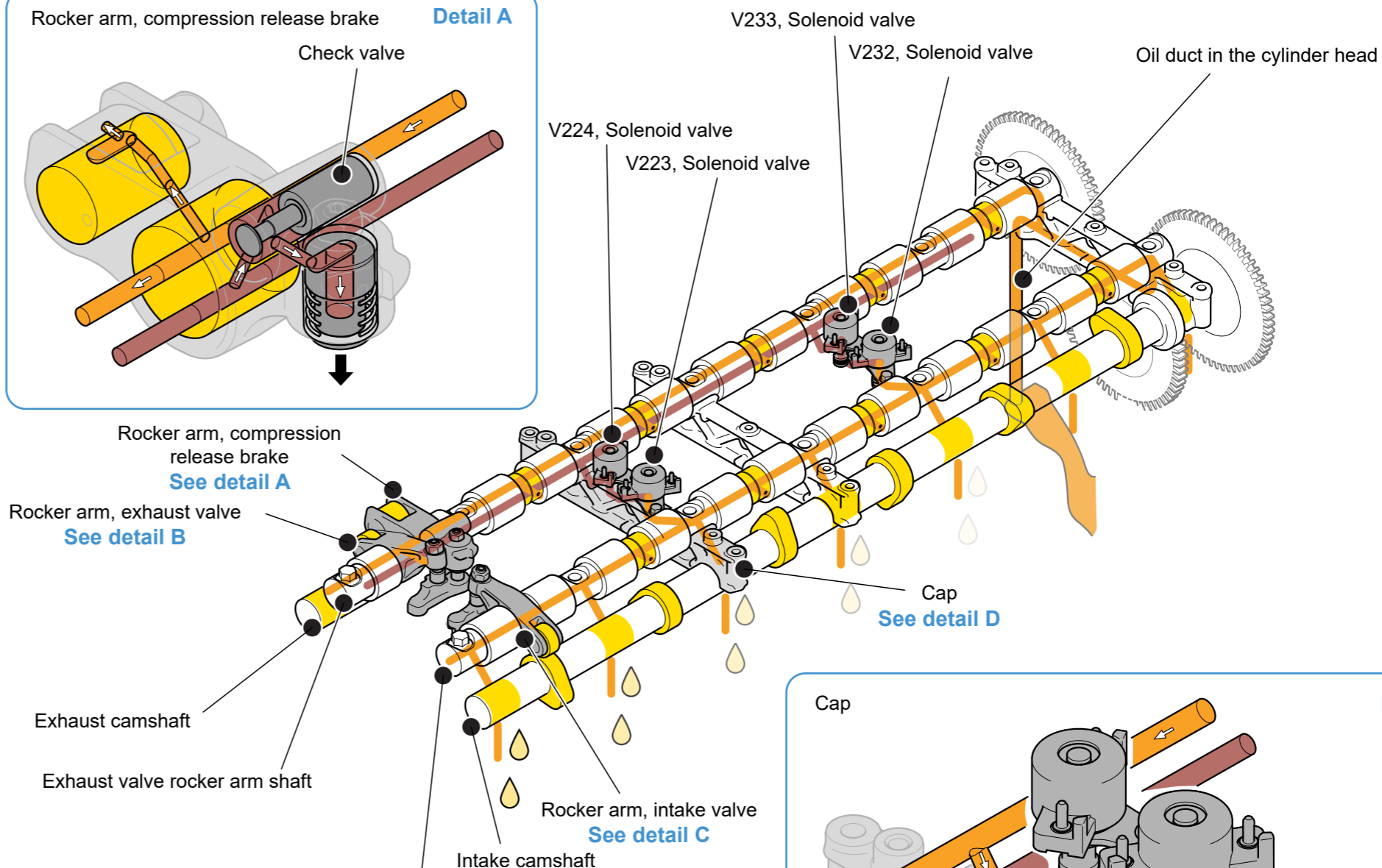

Cap  
See detail D

Cap

Detail D

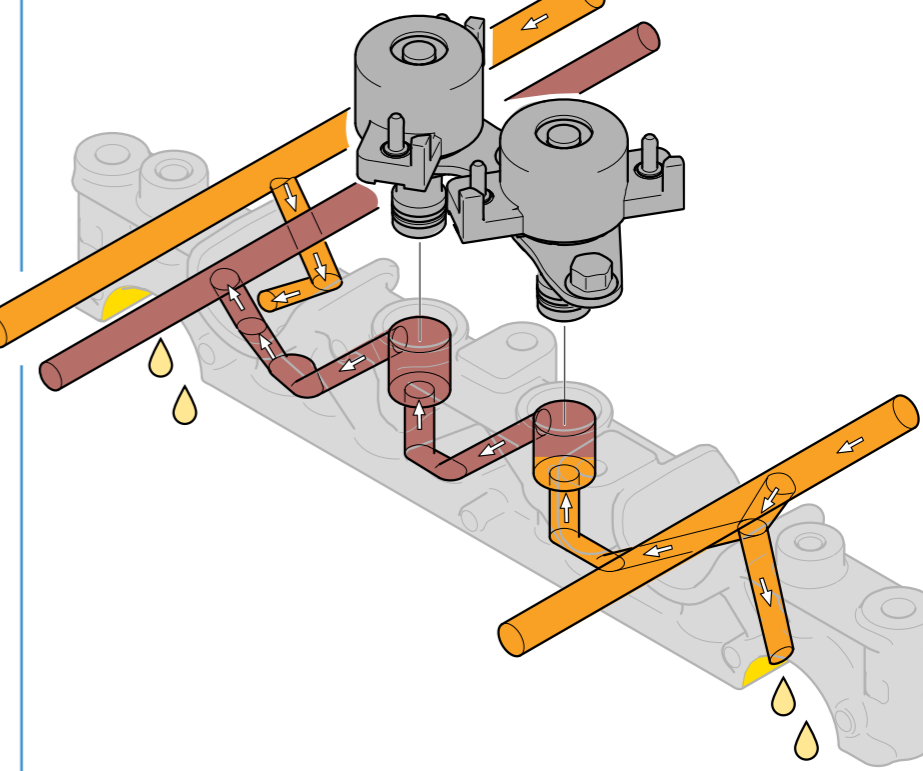

- Pressurised lubricating oil flow to component
- Valve regulated oil flow
- Lubricated surface

# LUBRICATION SYSTEM Crankshaft, connecting rods and pistons

## Industrial and marine engines with cylinder block generation 3



01:20-03 Issue 1 en-GB  
© Scania CV AB 2024, Sweden

**Detail A**

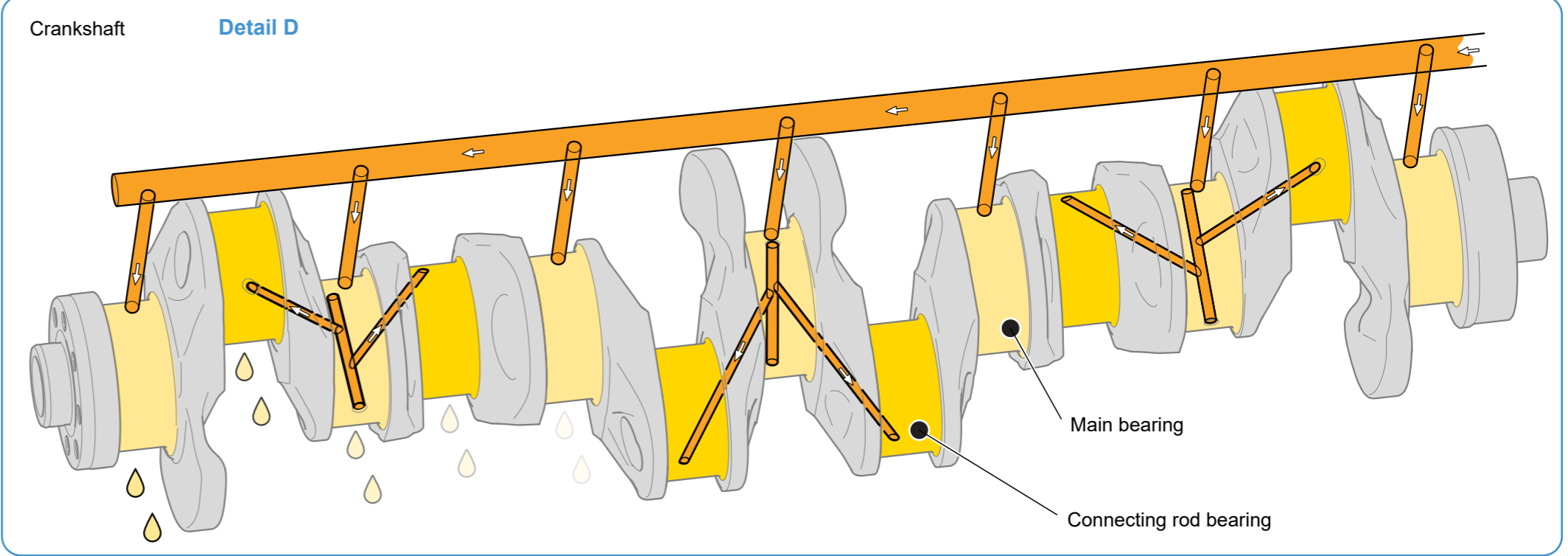
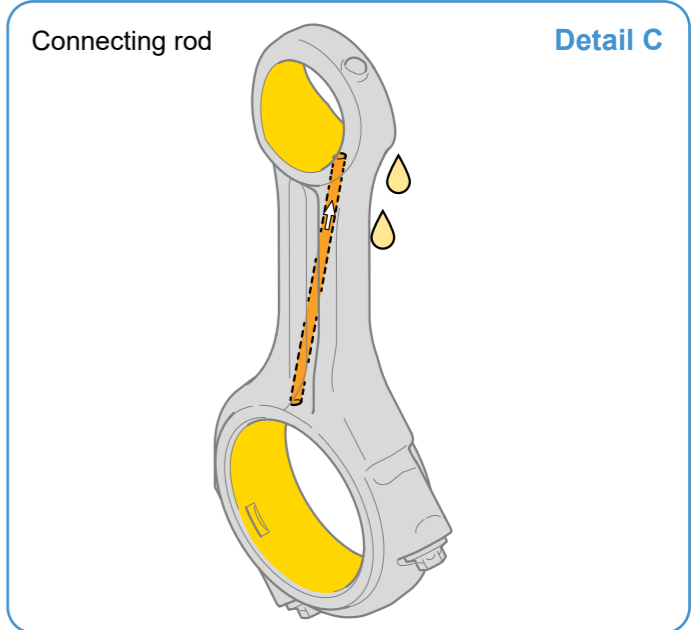
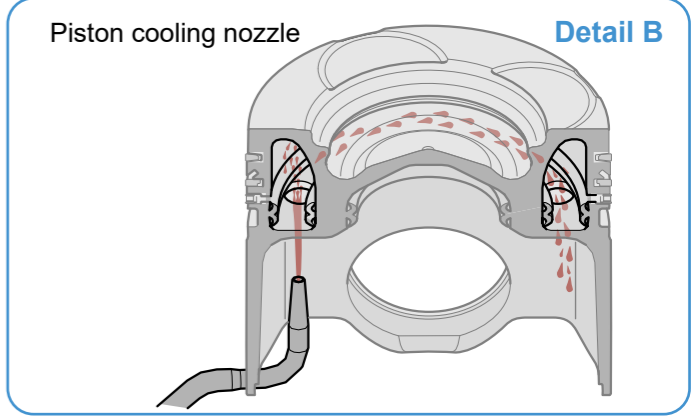
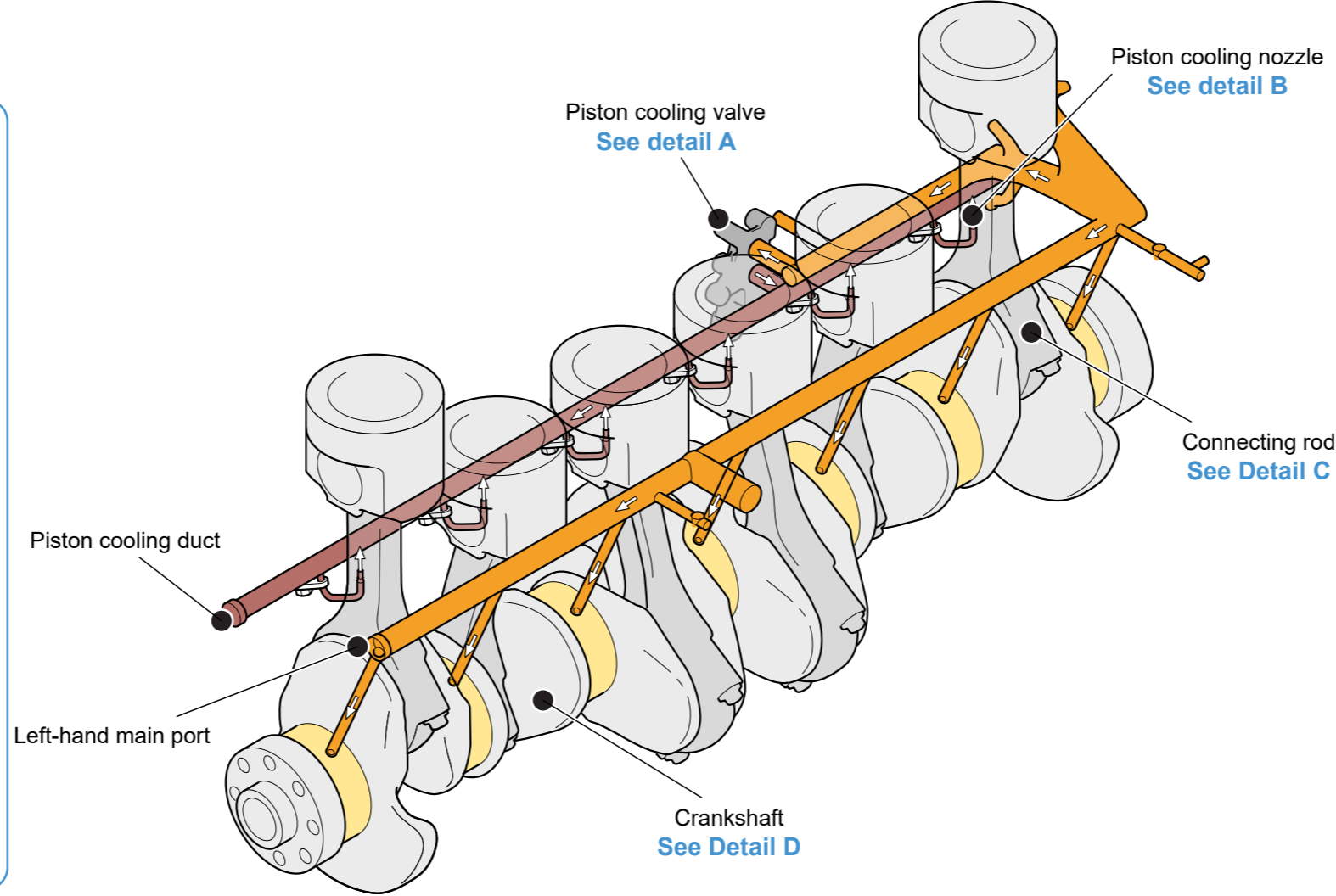
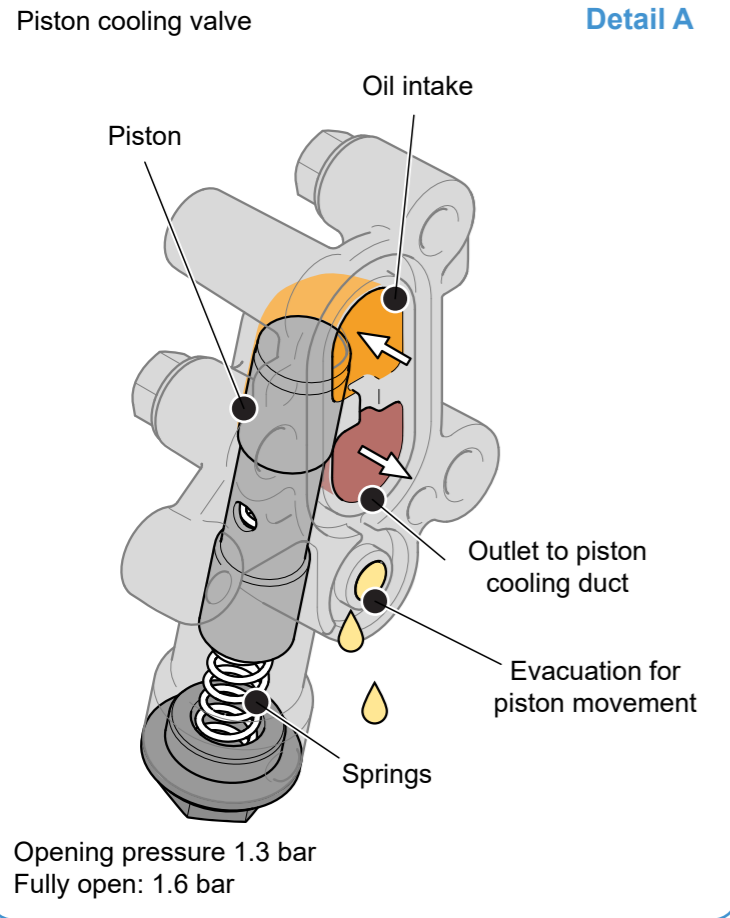

- Pressurised lubricating oil flow to component
- Valve regulated oil flow
- Lubricated surface, main bearing
- Lubricated surface, e.g. connecting rod bearing

# LUBRICATION SYSTEM Oil mist separator and turbocharger

## Industrial and marine engines with cylinder block generation 3

The crankcase gases are collected in the oil trap. Some oil is separated from the gases here and falls back into the cylinder head. From the rocker cover, the gases are transported down to the oil mist separator where the gases and the remaining oil are separated. The oil is returned to the engine crankcase. Depending on the engine configuration, the oil-separated crankcase gases are either led back to the inlet pipe upstream of the turbocharger (B) or away from the surrounding area, and in some cases out of the engine compartment through a hose (C).

The oil mist separator contains an impactor that separates oil and oil mist from the gases by allowing them to make contact with a surface where they are converted into larger drops.

The electric motor is controlled by a pressure and rotational speed sensor, which makes sure that the pressure is -5 mbar under normal operating conditions and warns if the pressure changes.

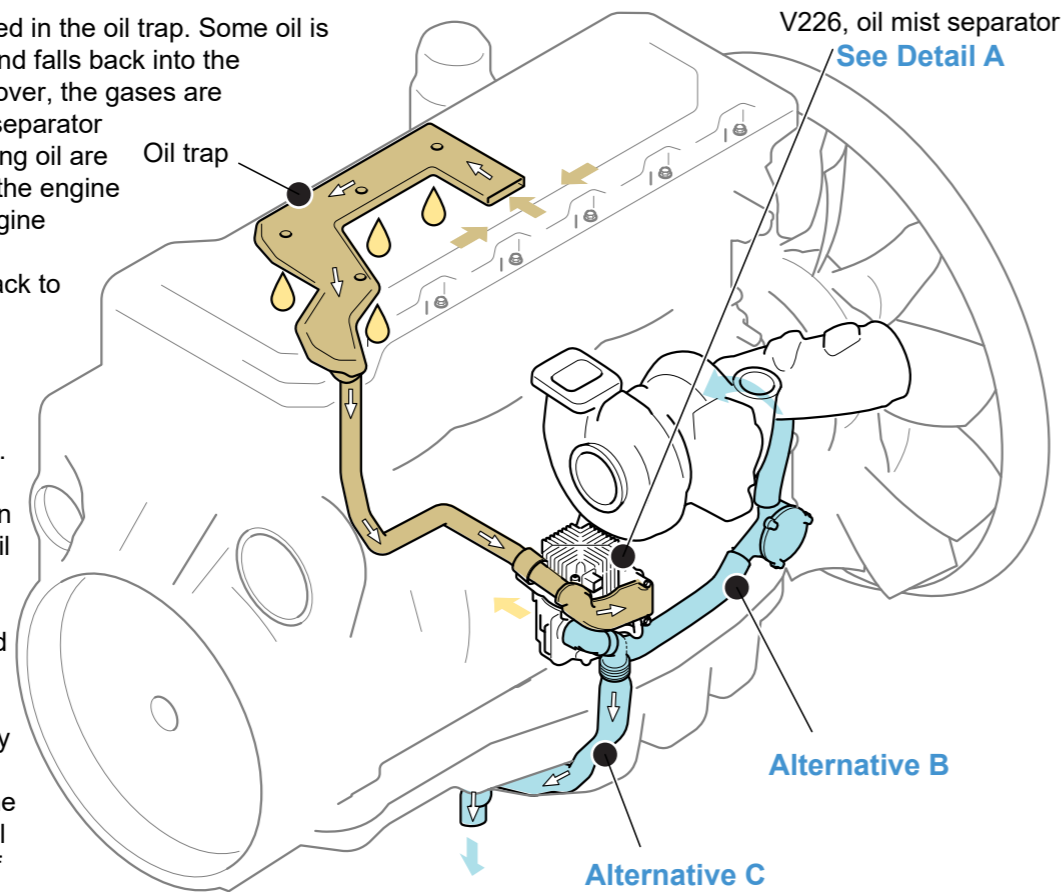

V226, oil mist separator

Detail A

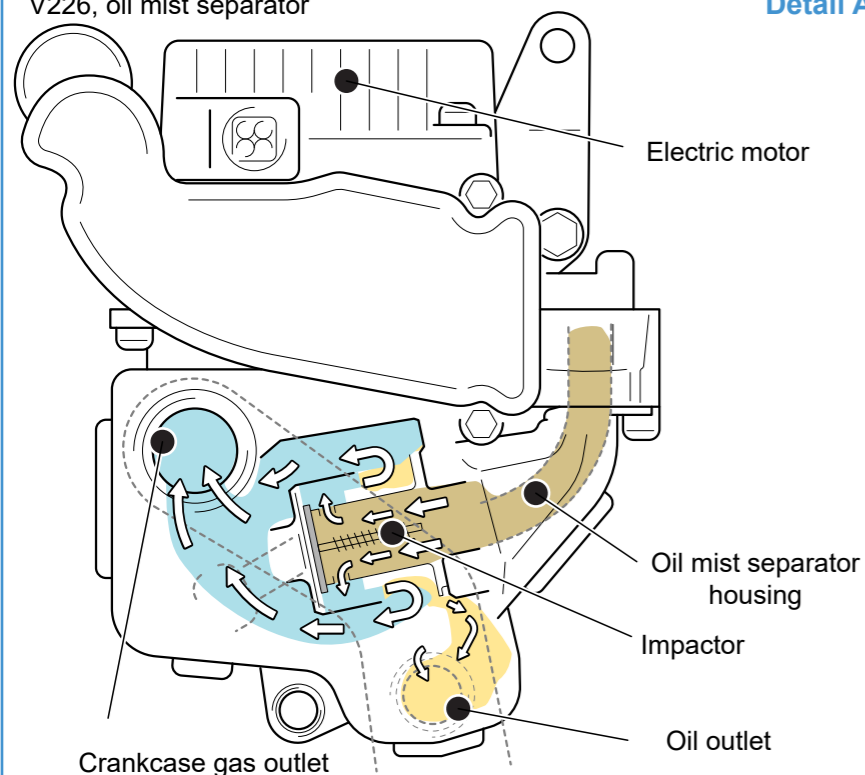

- Crankcase gases
- Oil separated crankcase gases
- Separated oil to oil sump

Compressor and turbine wheels  
See Detail D

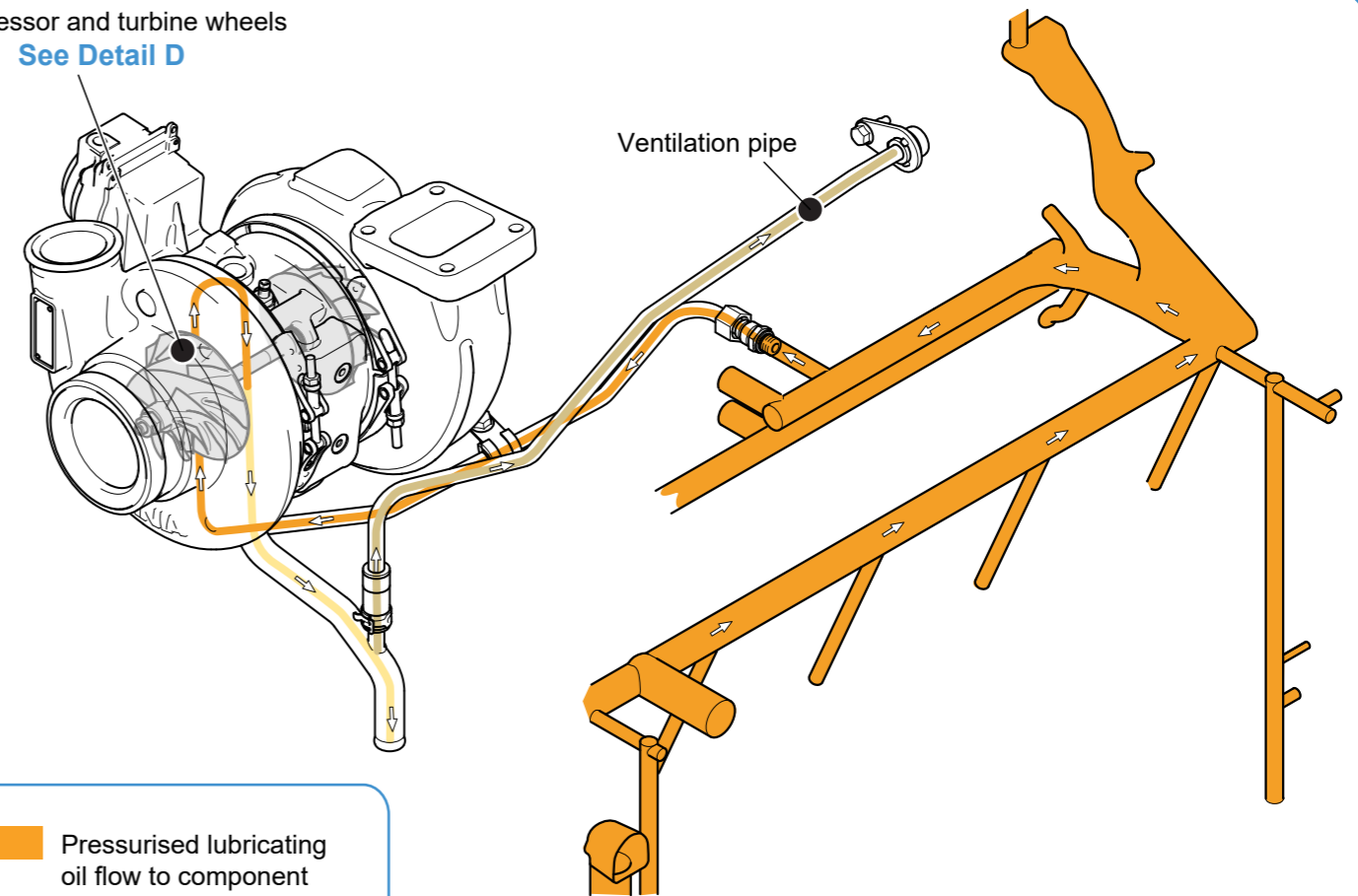

- Pressurised lubricating oil flow to component
- Lubricating oil to the oil sump

There is an oil pipe leading from the cylinder block that transports the lubricating oil to the turbocharger. The compressor and turbine wheels rotate very rapidly.

At full power, rotational speed is approx. 100,000 rpm. At the same time, the temperature at the turbine wheel is above 600°C.

This places high demands on the rotating parts, on balance, cooling, lubrication and cleanliness.

The flow (depending on rotational speed) to the turbocharger is approx. 2-4 l/min.

The shaft between the turbine and the compressor is, depending on the type of turbocharger, either mounted in two radial bearings which rotate freely (in a thin oil film) and one thrust bearing in the bearing housing, or a 2-row ball bearing with an oil damper.

After the turbocharger, the lubricating oil goes to the oil sump via a return oil pipe.

The exhaust pipe for the turbocharger has a ventilation pipe which is connected to the crankcase via the timing gear casing.

This pipe serves to ventilate blow-by-gas from the turbocharger bearing housing when the engine is running at an angle.

Compressor and turbine wheels

Detail D

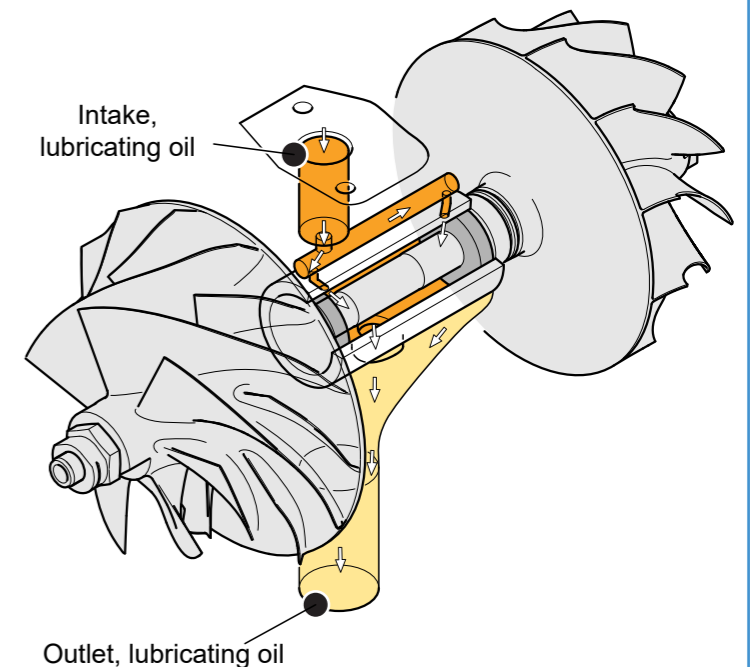

# LUBRICATION SYSTEM Oil filter

## Industrial and marine engines with cylinder block generation 3

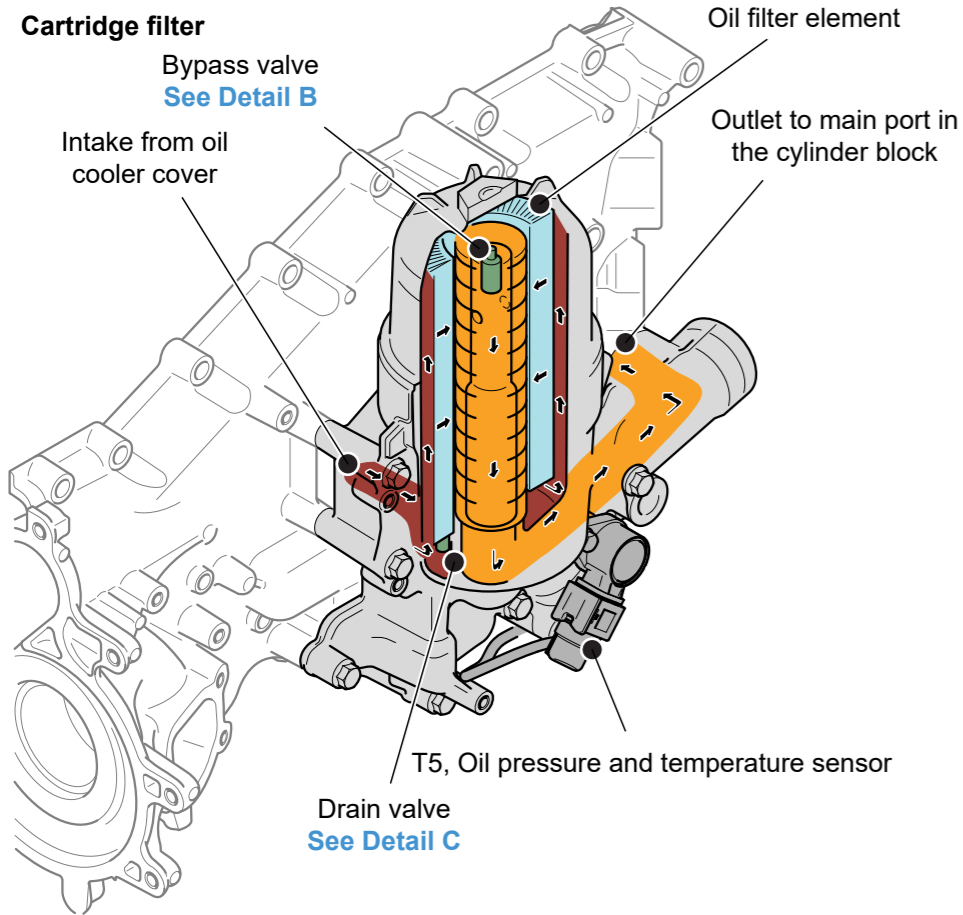

**Bypass valve** **Detail B**

Opens at 3.5 bar differential pressure across the filter element.

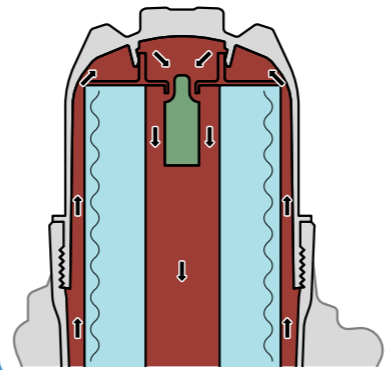

**Drain valve** **Detail C**

Opens when the filter is lifted out.

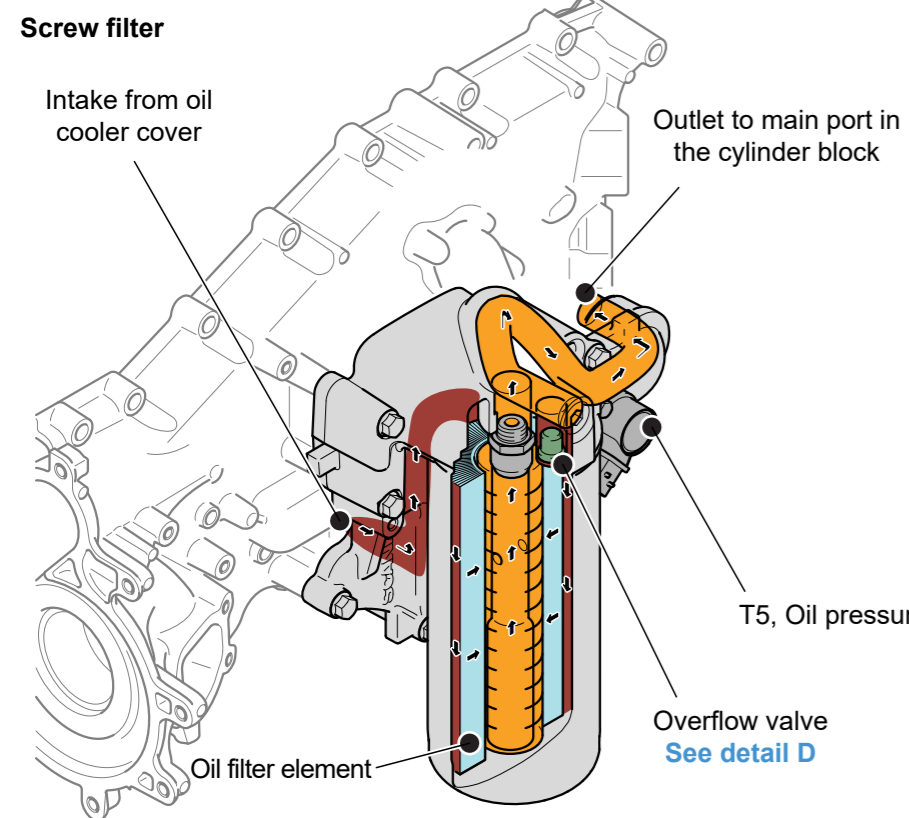
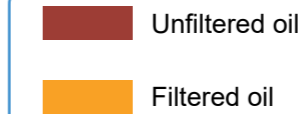
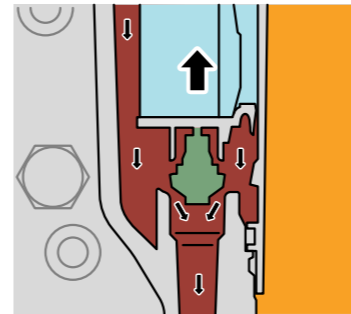

**Overflow valve** **Detail D**

The overflow valve is located in the filter head and opens at a pressure of 2 bar.

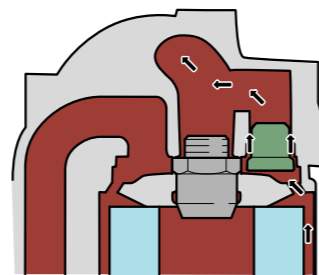

**Chassis-mounted oil filter**

