

SCANIA

07:02-01

Issue 2 en

Driving front axle AMD900

Work Description

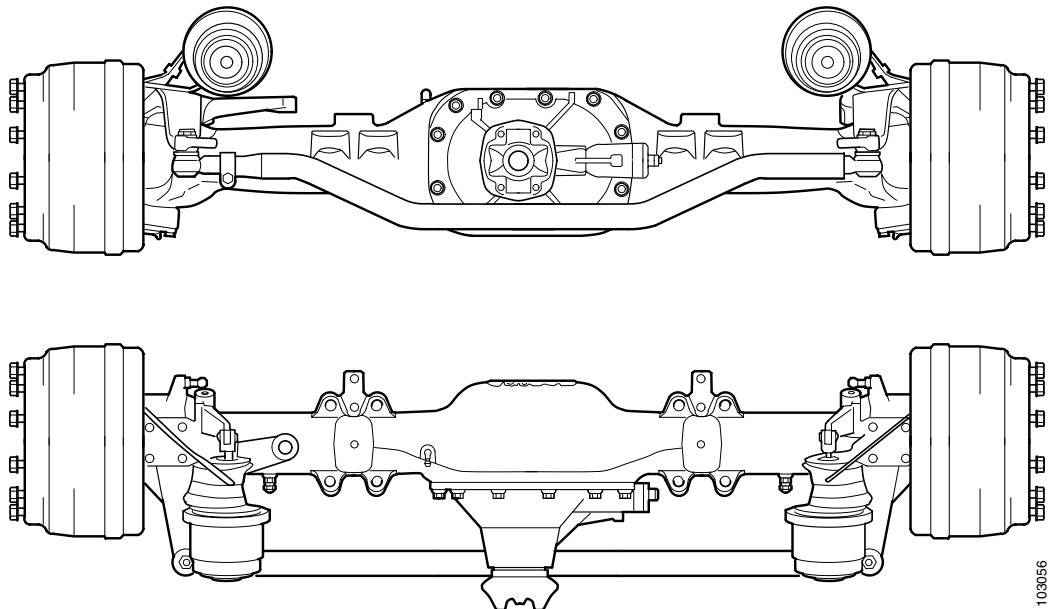

Contents

General	Important	3
	Exploded view drawing, hub reduction gear	4
	Exploded view drawing, axle beam.....	6
	Exploded view drawing, hub with ABS	8
Work Description	Renewing axle	10
	Hub dismantling	17
	Hub reduction gear	24
	Shaft journal dismantling	27
	Half shaft dismantling	31
	Axle beam dismantling.....	32
	Central gear, removing and fitting	34
	Axle beam, assembling.....	35
	Half shaft, assembling	38
	Shaft journal, assembling	40
	Hub, assembling	44
	Specifications	52

General

Important

A clean working environment is a condition for correct function and long lifetime for axle gears and wheel hubs.

Always clean the outside and surrounding parts to prevent contaminants entering the axle gear or the hub when the components are removed from the axle beam.

Clean all parts, new as well as old, before reassembling the gear.

All moving parts should be lubricated before being fitted.

Always use lubricants as specified in group 0 in the workshop manual.

Exploded view drawing, hub reduction gear

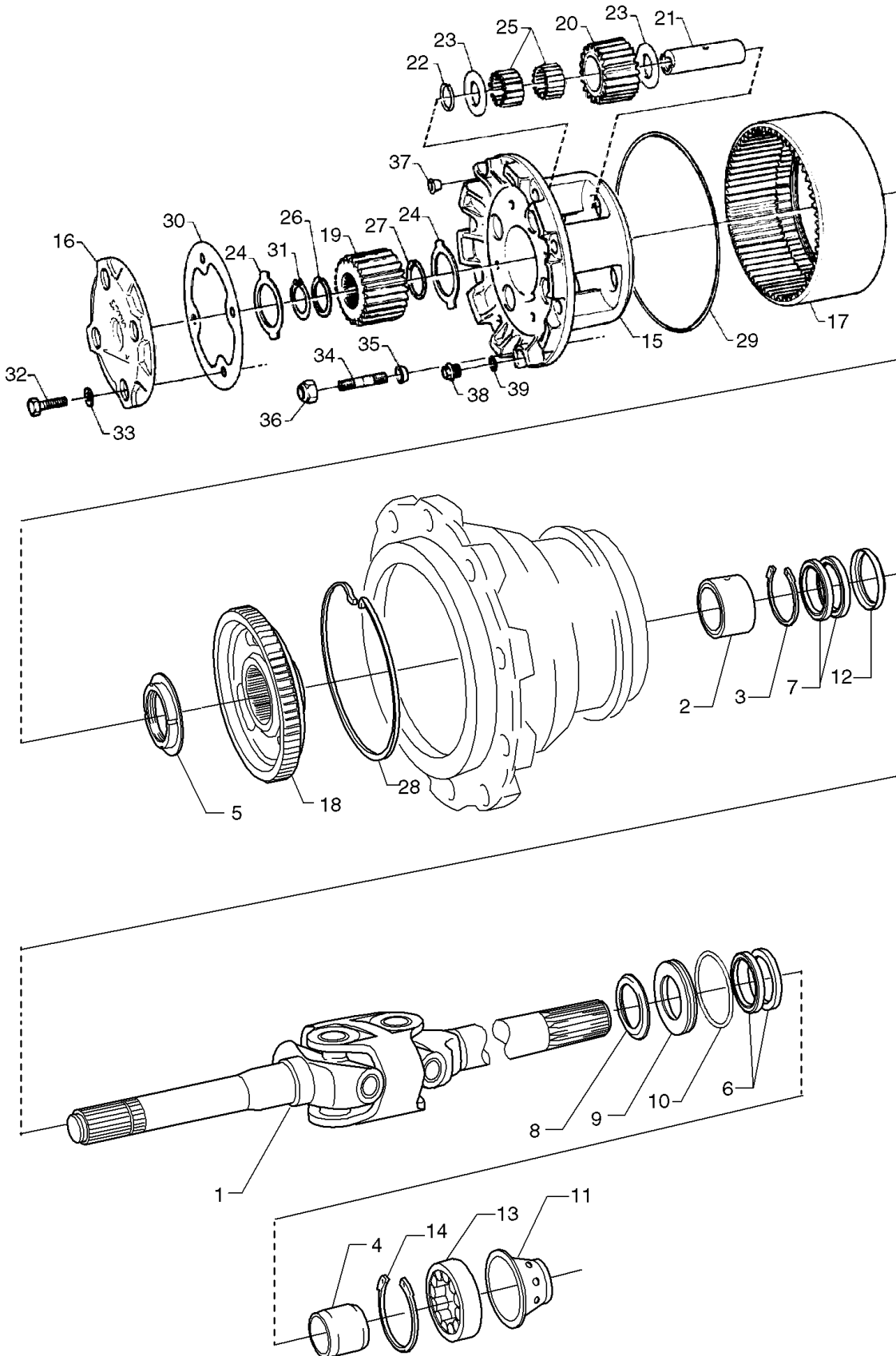

132293

- 1 *Half shaft*
- 2 *Needle bearing*
- 3 *Retaining ring*
- 4 *Bearing inner race*
- 5 *Nut*
- 6 *Seal*
- 7 *Seal*
- 8 *Seal*
- 9 *Seal seat*
- 10 *O-ring*
- 11 *Sleeve*
- 12 *Seal seat*
- 13 *Bearing*
- 14 *Snap ring*
- 15 *Planet wheel carrier*
- 16 *Cover*
- 17 *Ring gear*
- 18 *Ring gear retainer*
- 19 *Sun wheel*
- 20 *Planet gear*
- 21 *Bearing journal*
- 22 *Snap ring*
- 23 *Thrust washer*
- 24 *Thrust washer*
- 25 *Needle bearing*
- 26 *Thrust washer*
- 27 *Wire ring*
- 28 *Snap ring*
- 29 *O-ring*
- 30 *Gasket*
- 31 *Snap ring*
- 32 *Hexagon bolt*
- 33 *Cup spring*
- 34 *Stud*
- 35 *Cone*
- 36 *Nut*
- 37 *Plug*
- 38 *Magnetic plug*
- 39 *O-ring*

Exploded view drawing, axle beam

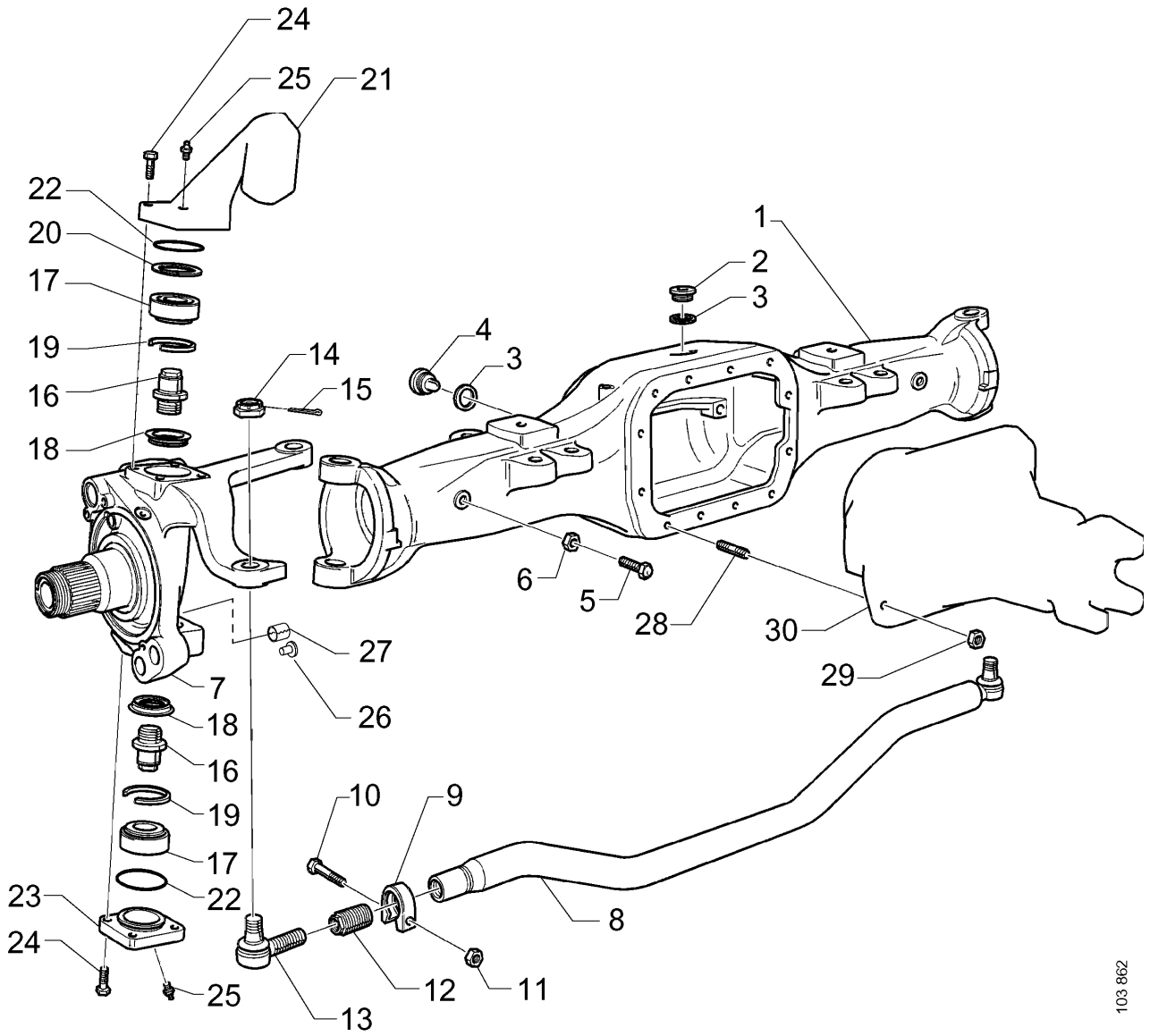

103 862

- 1 *Axle beam*
- 2 *Plug*
- 3 *Sealing washer*
- 4 *Magnetic plug*
- 5 *Bolt*
- 6 *Hexagon nut*
- 7 *Shaft journal*
- 8 *Link*
- 9 *Clamp*
- 10 *Bolt*
- 11 *Nut*
- 12 *Adjusting sleeve*
- 13 *Ball joint*
- 14 *Nut*
- 15 *Split pin*
- 16 *Swivel pin*
- 17 *Bearing*
- 18 *Seal*
- 19 *Spring*
- 20 *Shim*
- 21 *Bracket*
- 22 *O-ring*
- 23 *Cover*
- 24 *Hexagon bolt*
- 25 *Grease nipple*
- 26 *Plug*
- 27 *Sleeve*
- 28 *Stud*
- 29 *Nut*
- 30 *Axle gear*

Exploded view drawing, hub with ABS

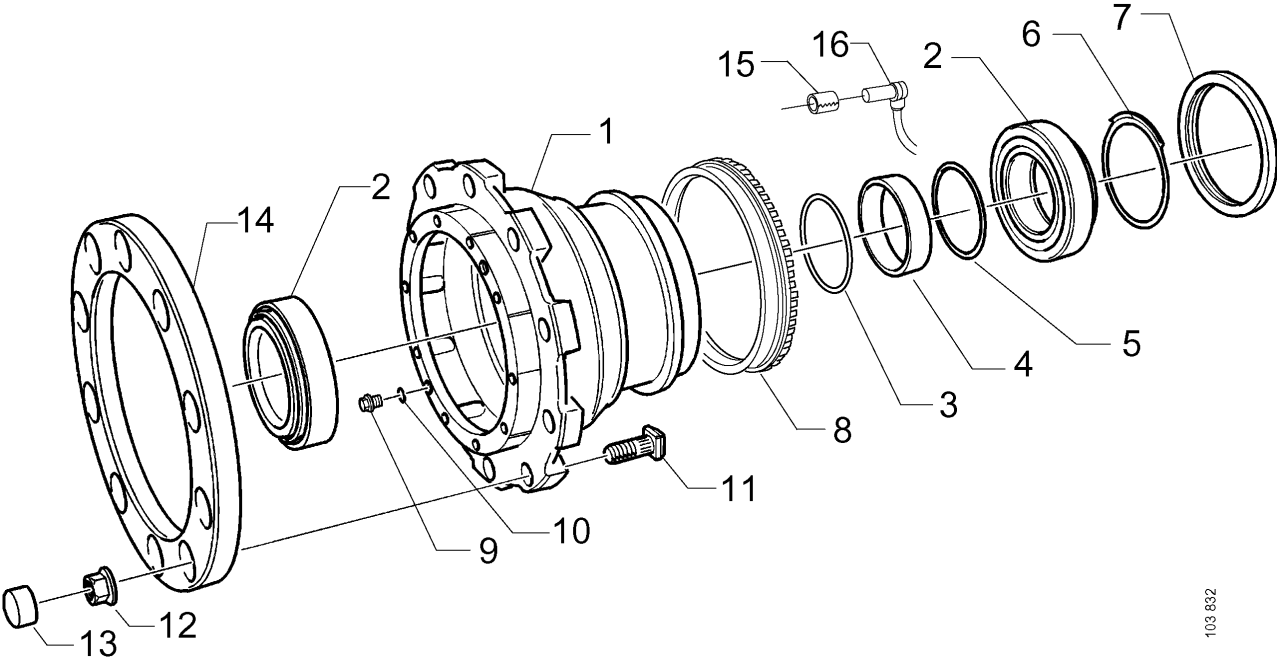

103 832

- 1 *Wheel hub*
- 2 *Roller bearing*
- 3 *O-ring*
- 4 *Spacing sleeve*
- 5 *Shim*
- 6 *Protective plate*
- 7 *Seal*
- 8 *Pulse wheel*
- 9 *Magnetic plug*
- 10 *O-ring*
- 11 *Wheel stud*
- 12 *Wheel nut*
- 13 *Nut cap*
- 14 *Cover*
- 15 *Sleeve*
- 16 *Sensor*

Work Description

Renewing axle

Tools

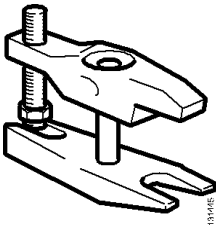
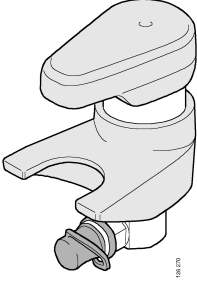
Number	Designation	Illustration	Tool board
99 345	Puller		AM3
588 608	Hydraulic ball joint puller		

Removal



WARNING!

Never work under a vehicle with air suspension, which is not fully secured against falling, in case there is a change of pressure in the air bellows. There is a risk of getting trapped and injured.

Both the chassis and moving axle suspension components must be secured against falling with stands to ensure absolute safety when working under a raised vehicle.

- 1 Lift up the vehicle and place it on stands as shown in the picture.
- 2 Remove the wheels.
- 3 Detach brake hoses and any connections for the ABS.
- 4 Detach electric and compressed air lines for the differential lock.
- 5 Remove the propeller shaft.

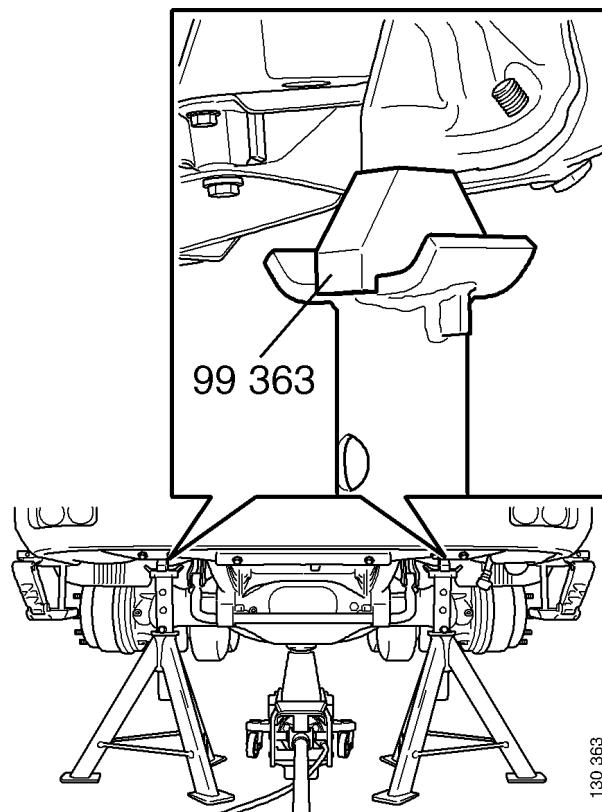

130 363

- 6 Disconnect the anti-roll bar from the front bracket.

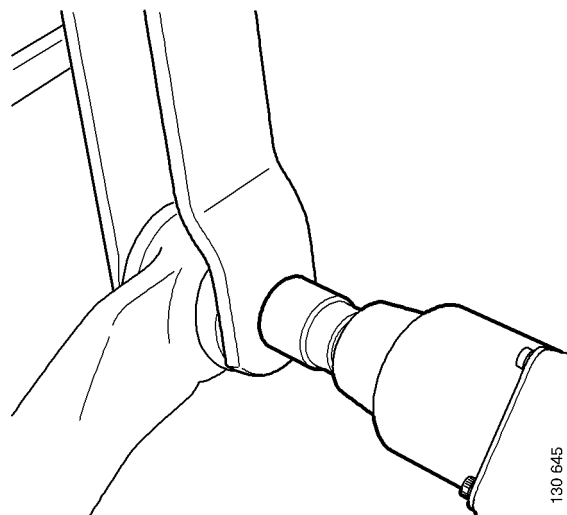

130 645

7 Remove the draglink using tool as shown in picture.

- Tighten the puller.
- Lightly tap the draglink arm and the puller as shown in the picture.
- Repeat these steps until the drag link comes off.



WARNING!

Keep in mind the risk of tipping when the axle is lowered and drawn out from the vehicle.

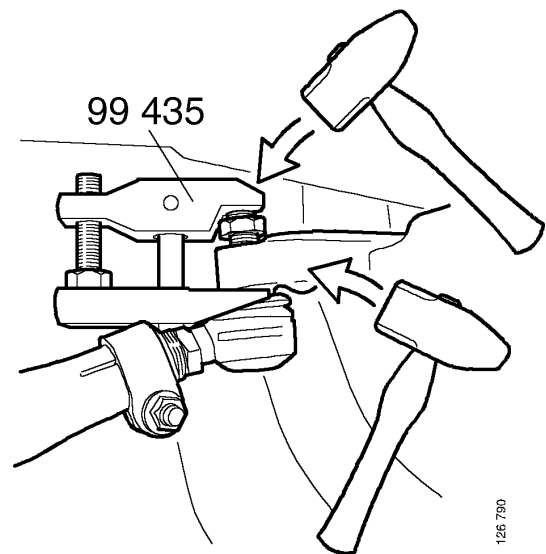
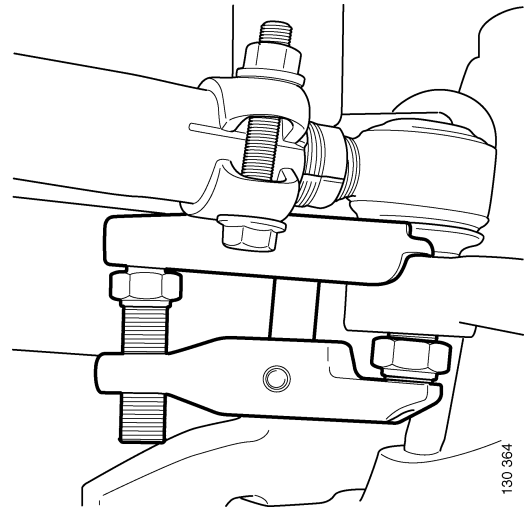

8 Remove the U-bolts and lower the axle onto two axle stands.

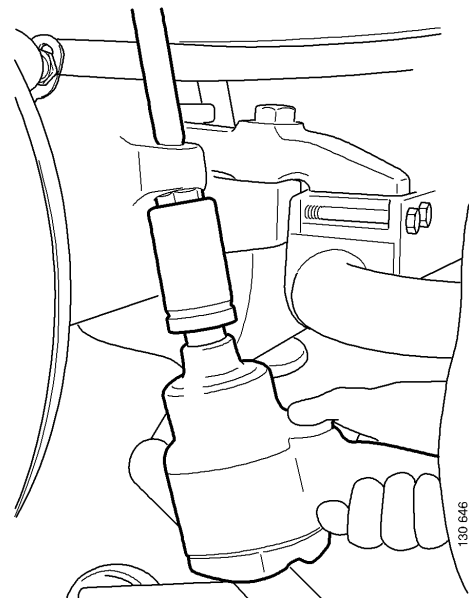

9 Draw out the axle using two pallet jacks.

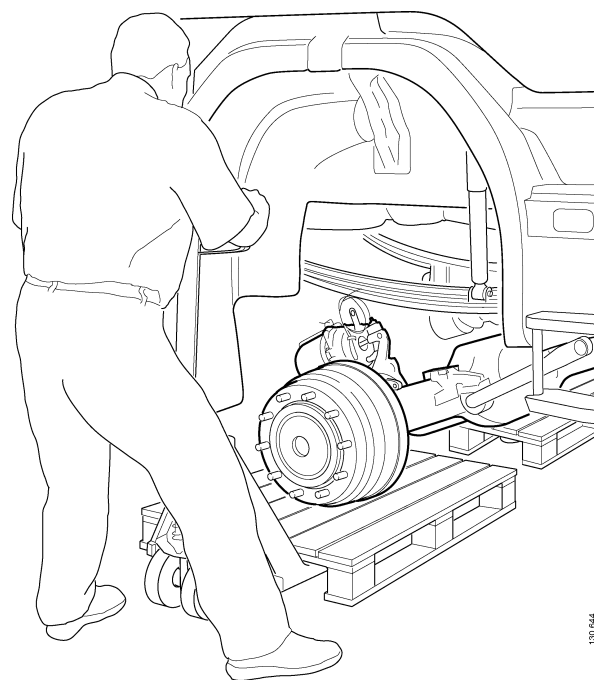

139 644

Fitting

- 1 Run the axle in under the vehicle.



WARNING!

Keep in mind the risk of tipping when the axle is run in under the vehicle and when it is lifted up against the springs.

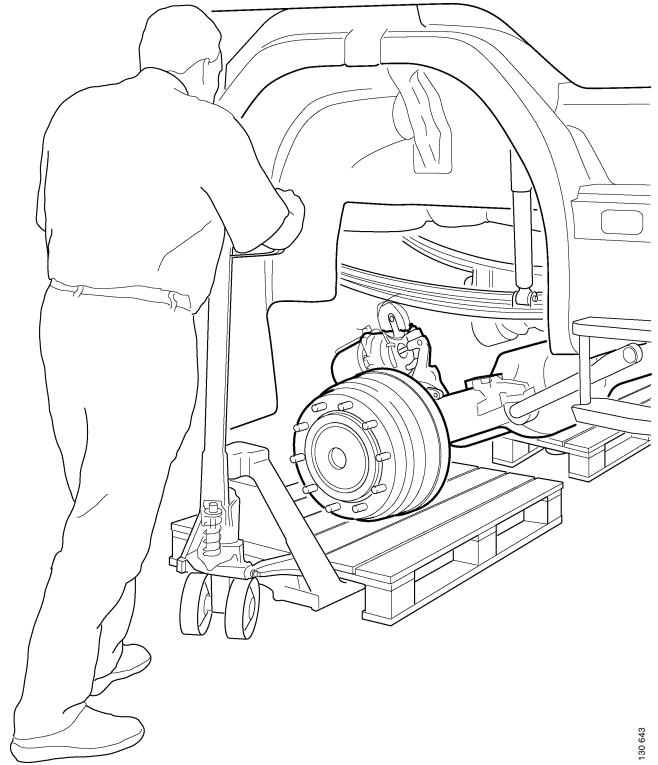

130 643

- 2 Clean and oil the U-bolt threads.

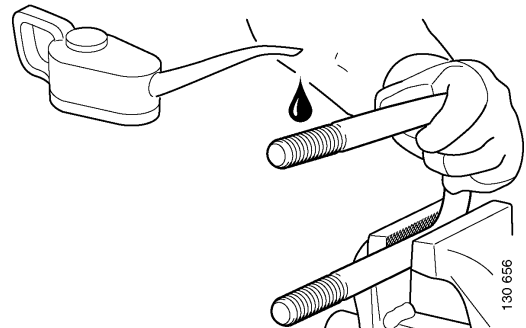
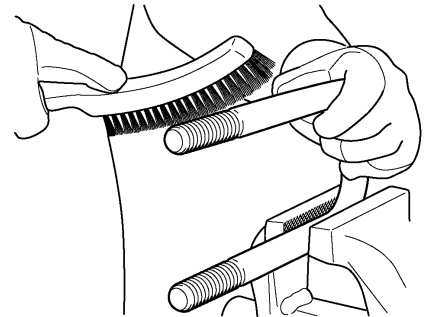

130 656

IMPORTANT! Tighten the U-bolts as specified in the tightening diagram described in service literature 12:01-01.

- 3 Fit new nuts and tighten the U-bolts as shown in the diagram.

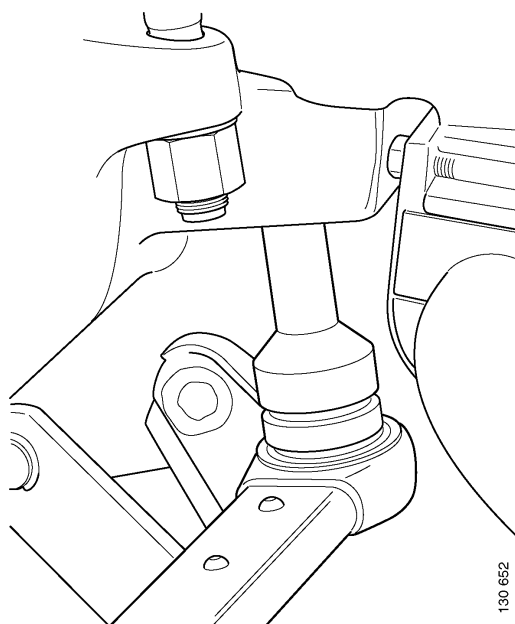

- 4 Fit the anti-roll bar and tighten the nuts to 180 Nm.

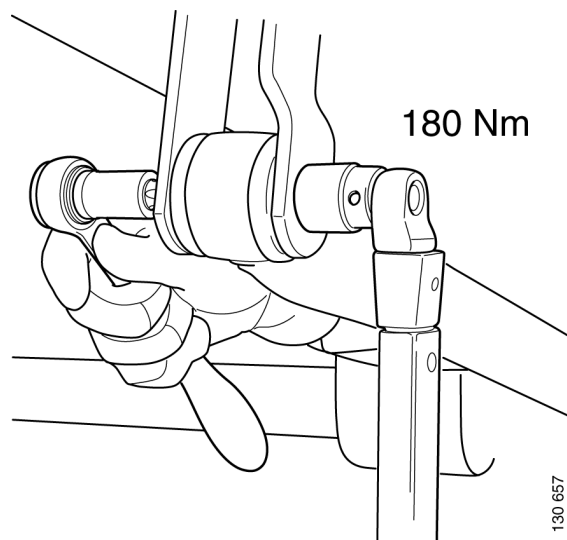

- 5 Fit the draglink and tighten the ball joint nut to 250 Nm and then further to the nearest hole.

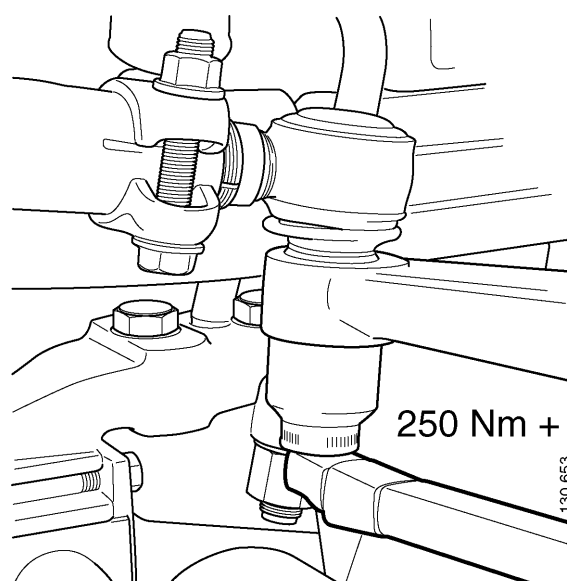

- 6 Lock the nut with a split pin.
- 7 Fit the propeller shaft and tighten the bolts as described in the workshop manual 06:01-01.
- 8 Fit the brake hoses and any connections for ABS.
- 9 Fit the electrical wiring and compressed air lines for the differential lock.
- 10 Adjust the brakes as described in the workshop manual 10:02-06.
- 11 Fill with oil (see Hub, assembly and Specifications).
- 12 Fit the wheels and lower the vehicle.
- 13 Retighten the U-bolt nuts when the axle is loaded.

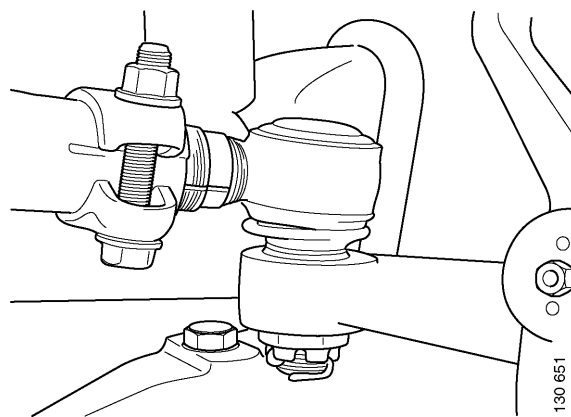





Note: The U-bolt nuts should be retightened after the vehicle has been in use equivalent to R-inspection. Refer to Workshop Manual group 0.

Hub

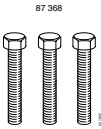
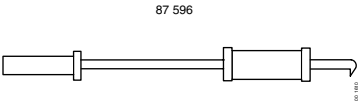
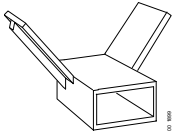
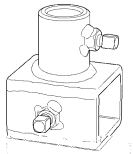
Dismantling

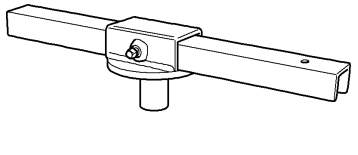
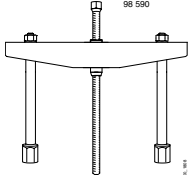
Tools

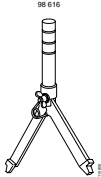
Number	Designation	Illustration	Tool board
87 368	Puller bolts		AD/AS1, B1
87 596	Slide hammer		D2
98 401	V block		F1
98 402	Holder for fixture shafts		F1
98 404	End yoke bracket		F1
98 405	Bracket and fixture beam		A
98 590	Puller		ADAS1

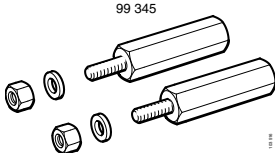
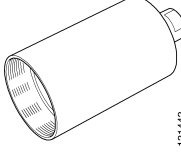
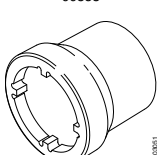
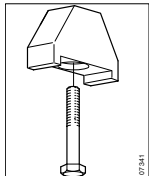
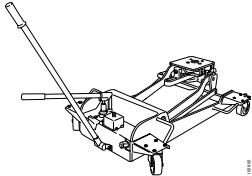
Number	Designation	Illustration	Tool board
98 616	Adjustable drift		AD2, R2
98 691	Support drift		AD/AS1
98 700	Short fixture shaft		F2
99 345	Adapter		B2
99 351	Sleeve for wheel bearing setting		AM3
99 353	Special sleeve		AM3
99 363	Stand tool		C1
587 313	Jack		A

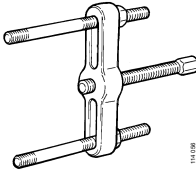
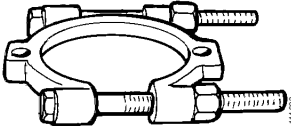
Number	Designation	Illustration	Tool board
587 428	Bearing puller		XA1
587 432	Puller plate		XA1

**WARNING!**

Never work under a vehicle with air suspension, which is not fully secured against falling, in case there is a change of pressure in the air bellows. There is a risk of getting trapped and injured.

Both the chassis and moving axle suspension components must be secured against falling with stands to ensure absolute safety when working under a raised vehicle.

- 1 Lift and support the front axle. Remove the wheel(s) and brake components as specified in Workshop Manual 10:02-06.

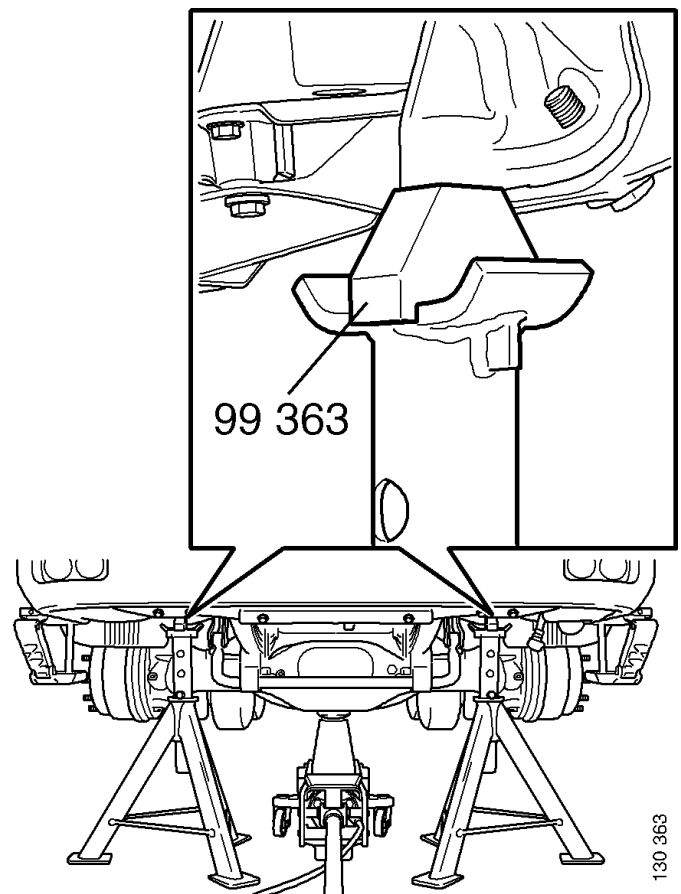

130 363

- 2 Drain the oil.

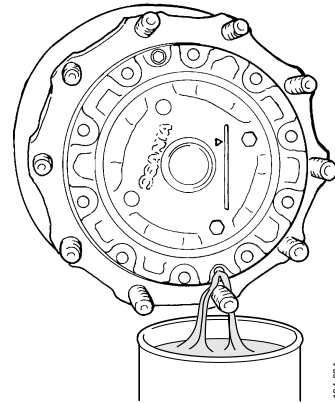

- 3 Remove the cover and outer thrust washer.

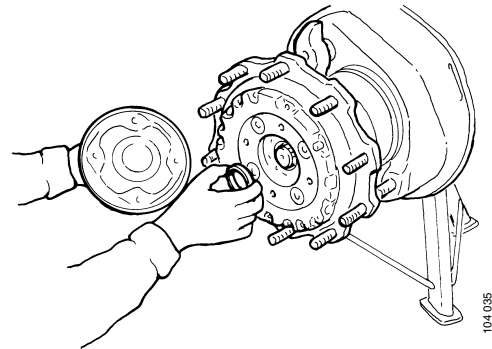

- 4 Loosen the nuts which hold the planetary unit in place, but leave them threaded a few turns.



WARNING!

If the lock nuts are not left in place, there is a great risk of the cones flying off at high speed when they release.

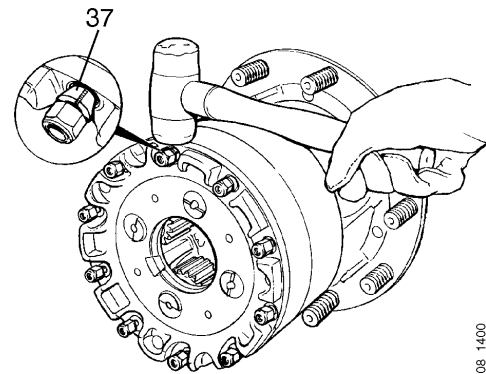

- 5 Tap on the sides of the planetary unit to loosen the cones.

- 6 Remove the plastic plugs for the puller hole.

- 7 Clean the puller hole with a pilot tap and remove the planetary unit using the puller bolts.

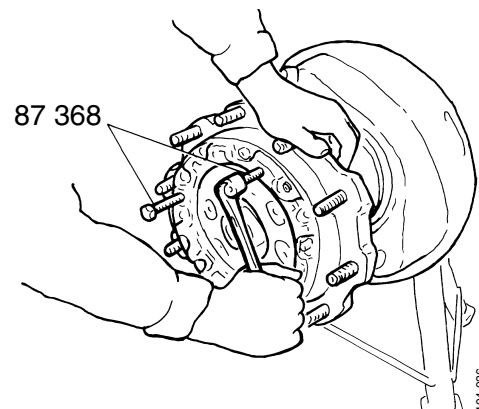

- 8 Remove snap ring 31, thrust washer 26, sun wheel 19, thrust washer 27 and wire ring 24.

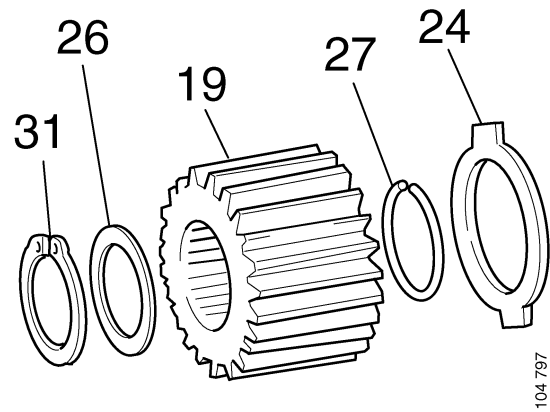

- 9 Remove the hub nut using splined socket 99 353.

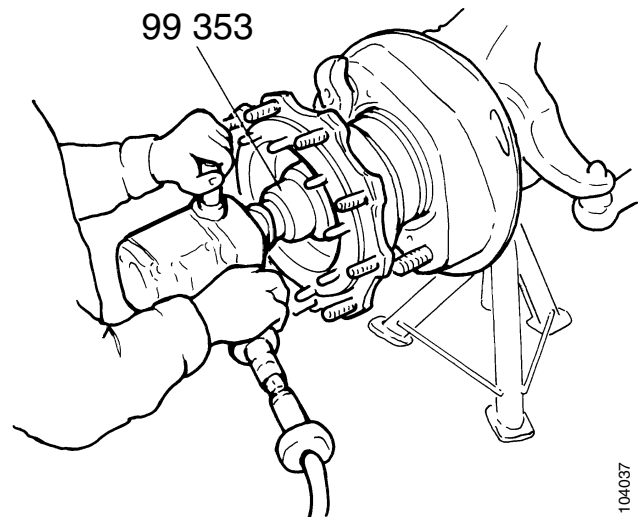

- 10 Set up gearbox jack 587 313 as shown in the picture.

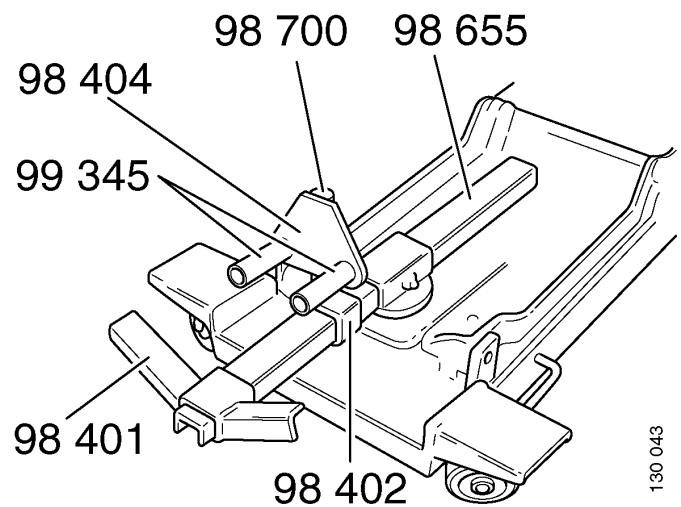

- 11 Set the gearbox jack up against the hub as shown in the picture.
- 12 Screw 99 351 (without thrust bearings and threaded dowel) on the shaft journal, screw pull rods 98 690 on two opposite wheel studs, fit puller 98 590, hold 98 691 against 99 351 and screw in the puller bolt.
- 13 Draw out the hub with internal ring gear and ring gear retainer.
- 14 Remove internal ring gear and ring gear retainer from the hub.
- 15 Remove the internal ring gear from the ring gear retainer.

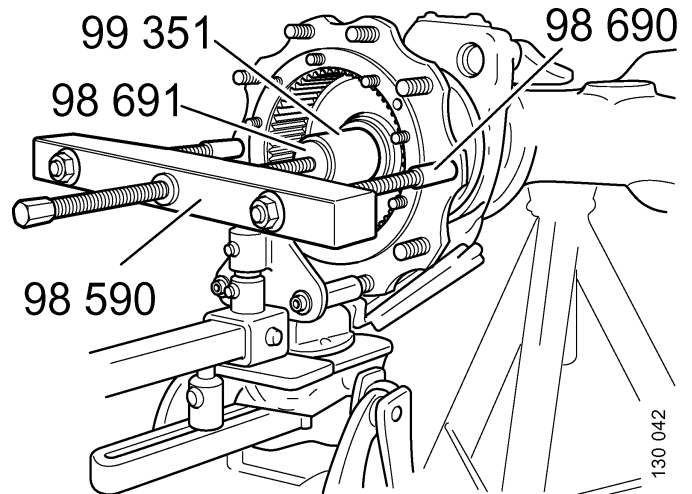

- 16 Remove the outer wheel bearing from the ring gear retainer as shown in the picture, using three fully threaded bolts M10x80.

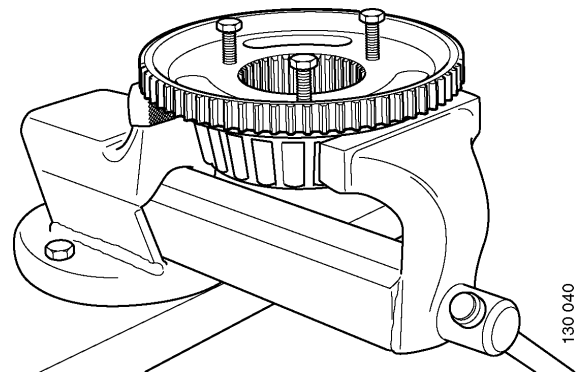

- 17 Remove the hub seal using a slide hammer.

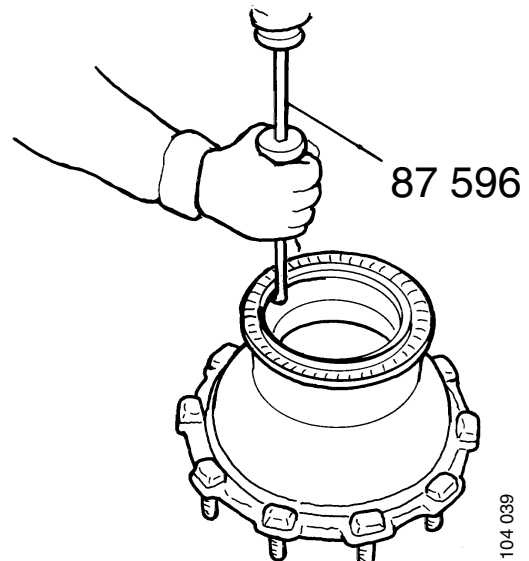

- 18 Remove four wheel studs (see picture) to facilitate supporting under the hub.
- 19 Remove the bearing outer races using 98 616.

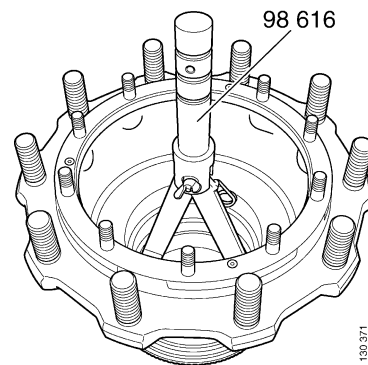
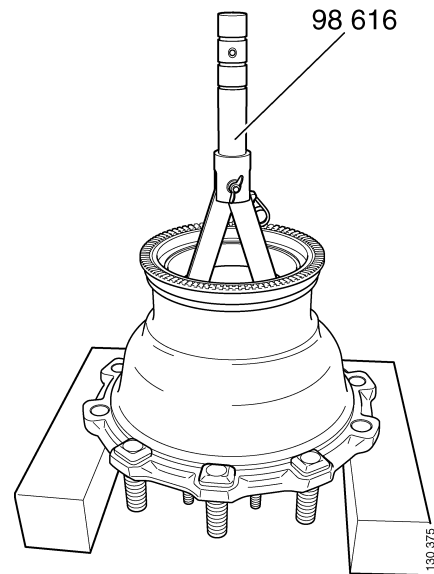

- 20 Remove the spacing sleeve, O-ring and shims.
- 21 Remove the brake camshaft and brake shield as described in the workshop manual 10:02-06.
- 22 Remove the inner wheel bearing using puller 587 428 and puller plate 587 432 (tighten the puller plate bolts hard so it grips well), spacer 99 691 and sleeve 99 351 (without thrust bearing and threaded dowel). Remove the protective plate on the inside of the bearing.

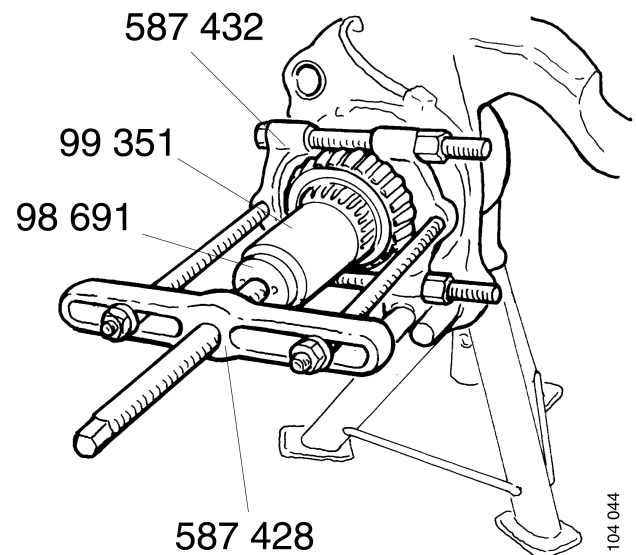

Hub reduction gear

Renewing planet wheel bearings

Tools

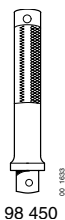
Number	Designation	Illustration	Tool board
98 450	Shank		AM1, AD/AS2, R2

- 1 Check that the four planet wheels rotate easily and without noise. Where there is a suspicion that one of the bearings are defective, all four bearings should be renewed at the same time.
- 2 Place the planet wheel carrier in a press as shown in the picture and press out the bearing journals.

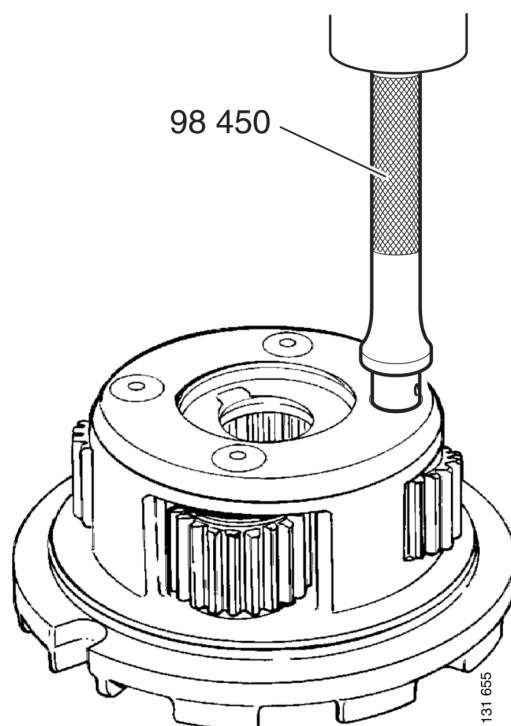

- 3 The needle bearings for each planet wheel consist of two rows of needles. The bearings are supplied in an outer and an inner cardboard tube, which can be used as a fitting tool. The inner cardboard tube is provided with plastic plugs on both sides of each bearing set.

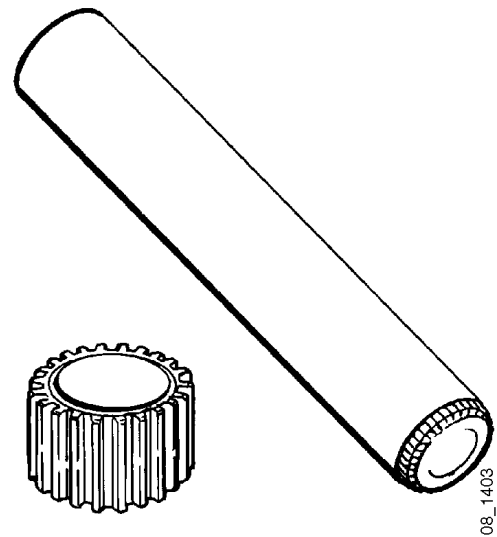

- 4 Oil the race in the planet wheel and then press in a set of needle bearings using, for example, shank 98 450.

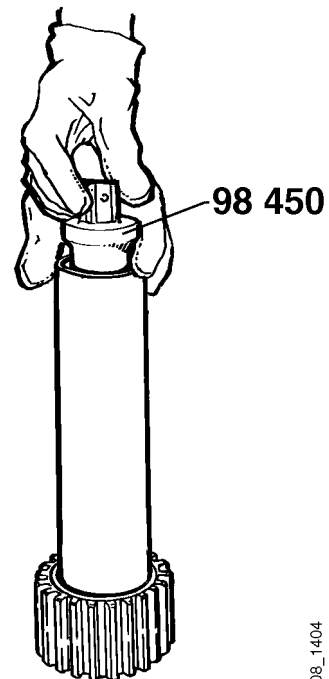

- 5 Carefully remove the plastic cover from the inner pipe.
- 6 Fit the two thrust washers, one on each side of the planet wheel. The washers should be oiled. Press down the inner pipe a little so that it centres the lower thrust washer.
- 7 Slip in the planet wheel with the two thrust washers in the planet wheel carrier.
- 8 Position the planet wheel carefully in the middle of the hole in the planet wheel carrier. Press down the inner pipe by hand so that it enters the hole for the bearing journal (a few mm).

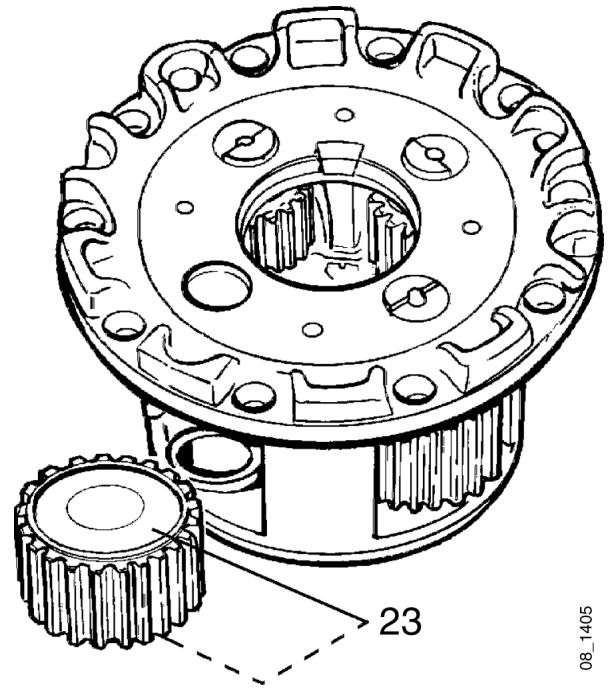

08_1405

- 9 Oil the bearing journal and turn it so the raised part is pointed towards the middle of the planet wheel carrier.

Note: The bearing journal's raised part must be directed in towards the middle of the planet wheel carrier as shown in the picture. The cover cannot otherwise be fitted.

- 10 Tap in the bearing journal using a plastic mallet, which forces out the cardboard pipe.

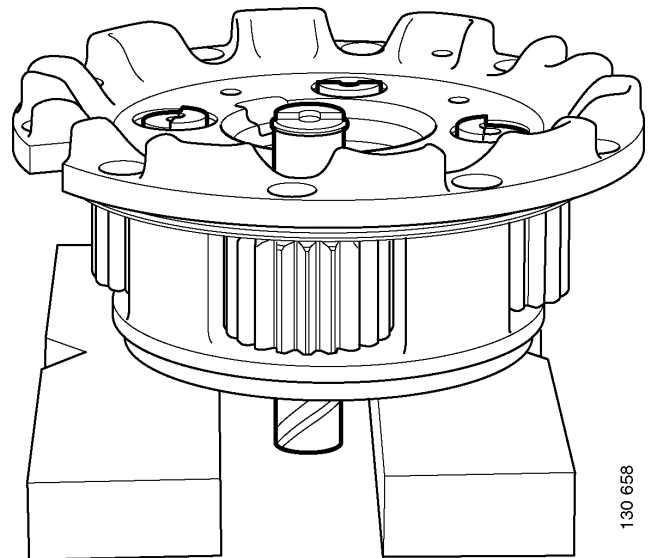



130 658

Shaft journal

Dismantling

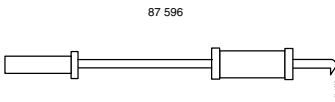
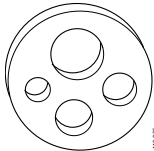
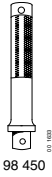
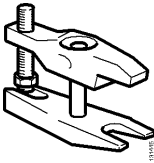
Tools

Number	Designation	Illustration	Tool board
87 596	Slide hammer		D2
98 224	Pressplate		
98 450	Shank		AM1, AD/AS2, R2
99 345	Puller		AM3
588 608	Hydraulic ball joint puller		

- 1 Remove the brake slack adjuster and the brake chamber (hang it up so that the brake hose is not strained). For working with brake components, see workshop manual 10:02-06.
- 2 Remove the brake chamber bracket.

3 Remove the draglink using puller 99 435.

- Tighten the puller.
- Tap lightly on the draglink arm and the puller as shown in the picture.
- Repeat these steps until the drag link comes off.

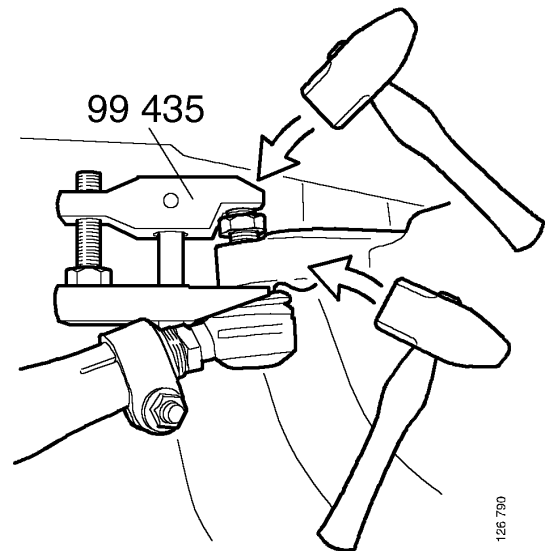
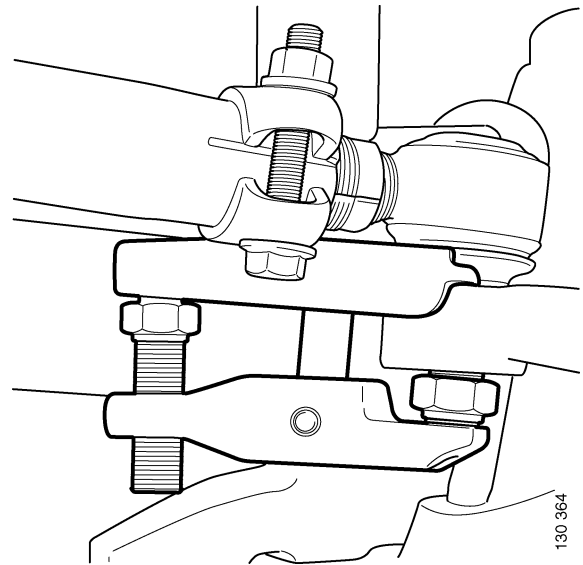

4 Remove the cover for the lower swivel pin. The outer bearing race can loosen and fall down.

5 Remove the lower swivel pin including bearing, spring and sealing.

Note: The thread is locked with locking compound. Careful heating may be needed to release the locking compound.

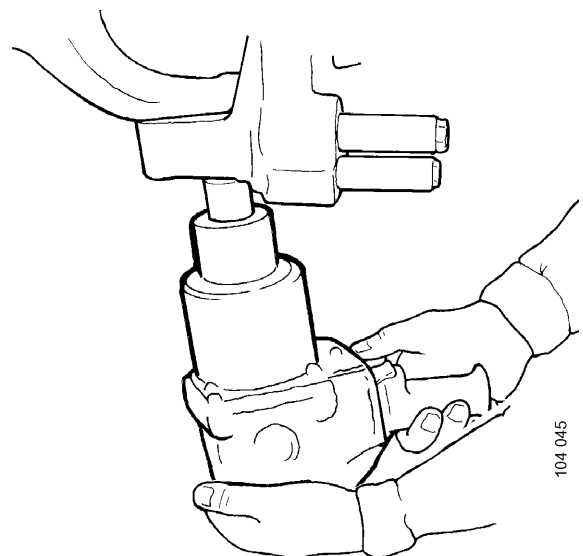

- 6 Remove the upper swivel pin including bearing, spring, sealing and shims. Save the shims and use them when assembling.

Note: The thread is locked with locking compound. Careful heating may be needed to release the locking compound.

- 7 Lower the shaft journal.

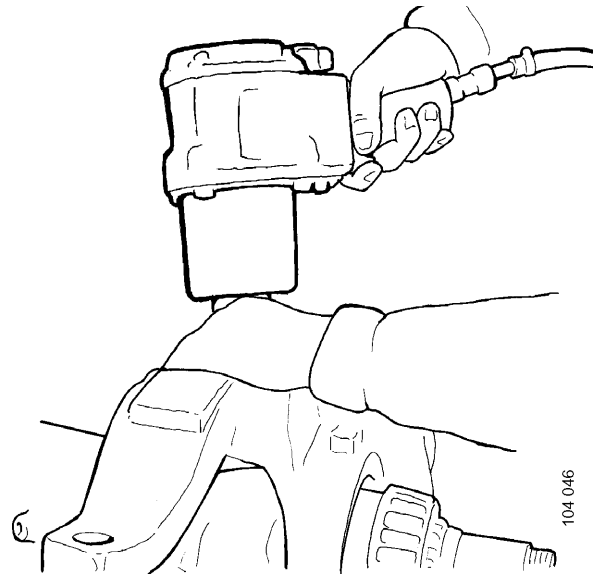

- 8 Remove the sealing ring retainer and the sealing rings using slide hammer 87 596.

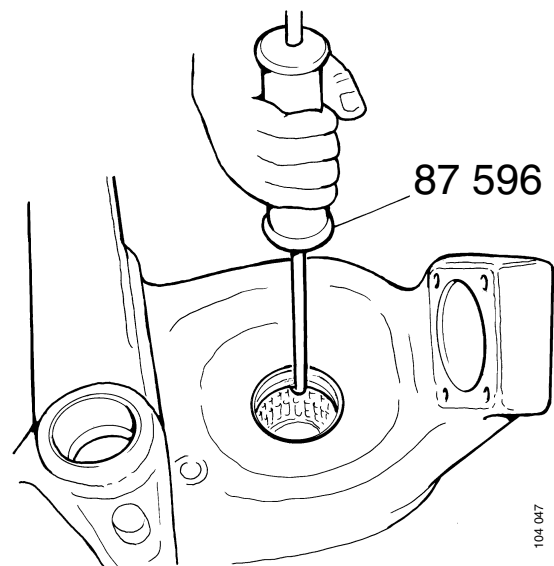

- 9 Remove the snap ring.

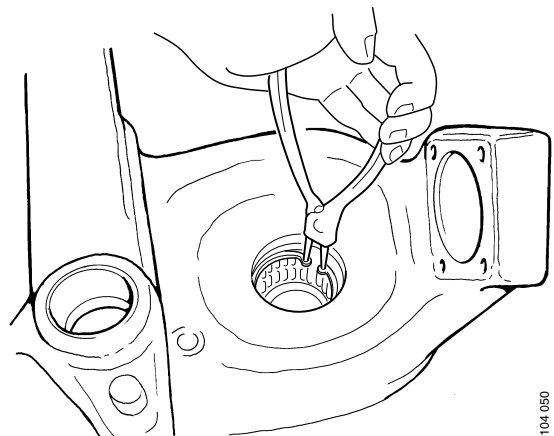

- 10 Tap loose the half shaft bearing using a drift.

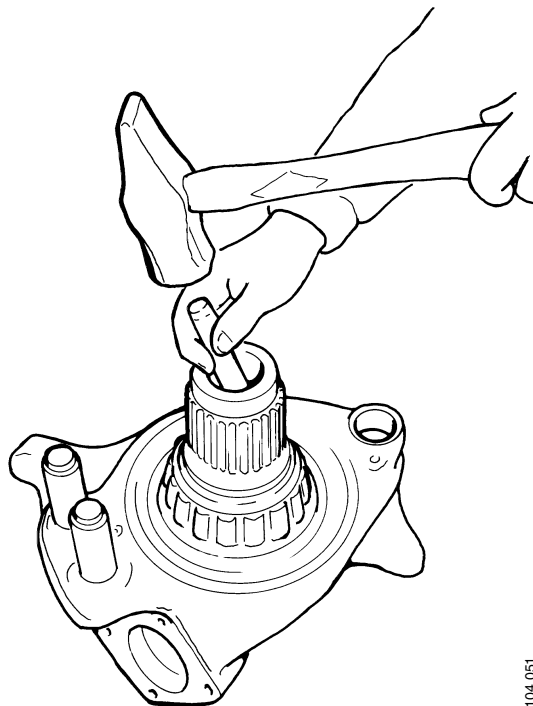

104 051

- 11 Remove the swivel pin bearing inner races in a press using pressplate 98 224, shank 98 450.

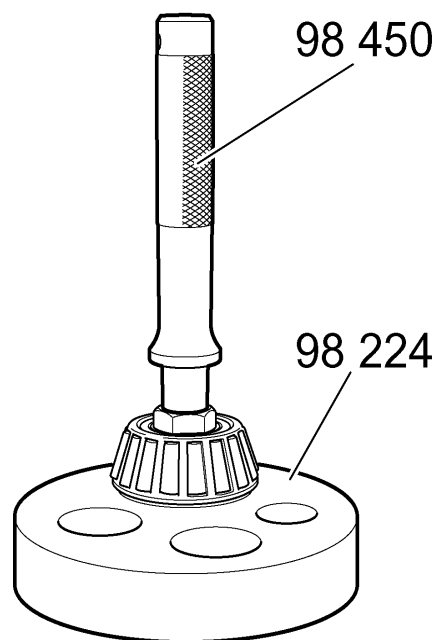

130 377

Half shaft

Dismantling

- 1 Draw out the half shaft. To remove the half shaft, the differential lock must be engaged using compressed air.



WARNING!

Wear protective goggles!

- 2 Remove the bearing inner races by grinding a groove and cracking them with a chisel. Protect the half shaft joint from grinding dust.

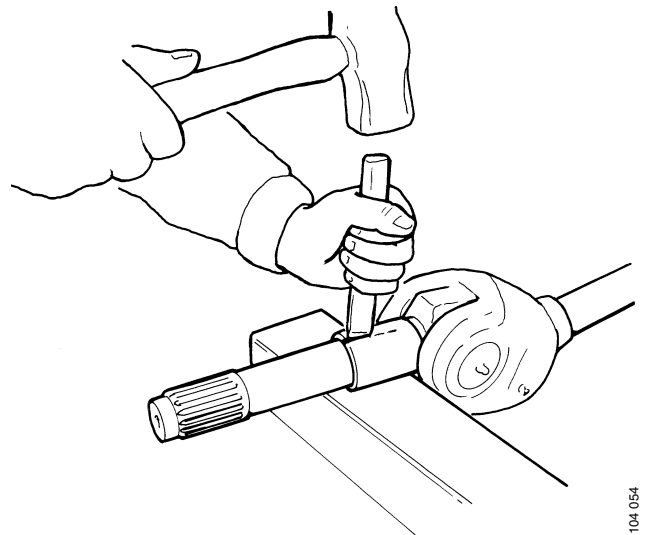



104 054

Axle beam

Dismantling

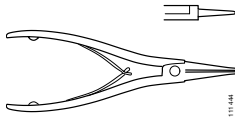
Tools

Number	Designation	Illustration	Tool board
587 311	Retaining ring pliers		G1
587 316	Puller		XA2
587 317	Expanding sleeve		XA2

1 Draw out the sealing ring retainer.

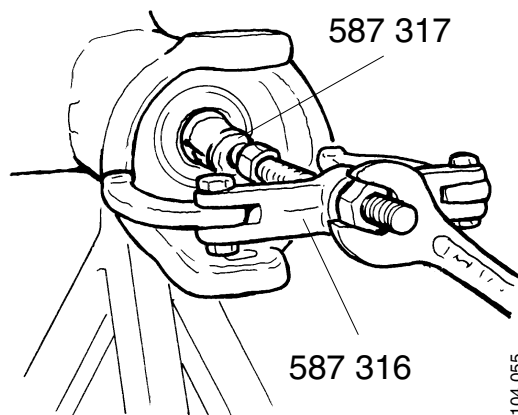

2 Remove the snap ring using 587 311.

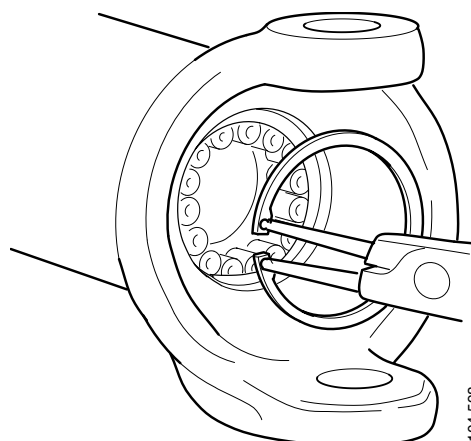

3 Draw out the half shaft bearing using puller 587 316 and 587 317.

Note: Carefully centre the puller.

4 Remove the sleeve.

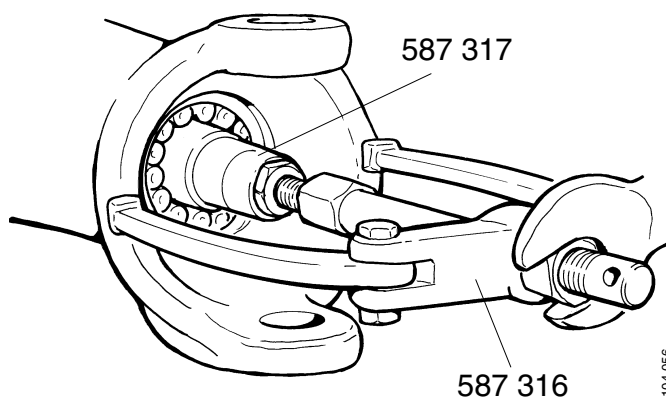

Central gear

Removing and fitting

Before the axle gear can be removed the shaft journals on both sides must be removed and the half shafts drawn out of the axle gear.

- For removing and fitting the central gear, see the workshop manual 08:05-01.
- For work on the central gear, see the workshop manual 08:05-01.

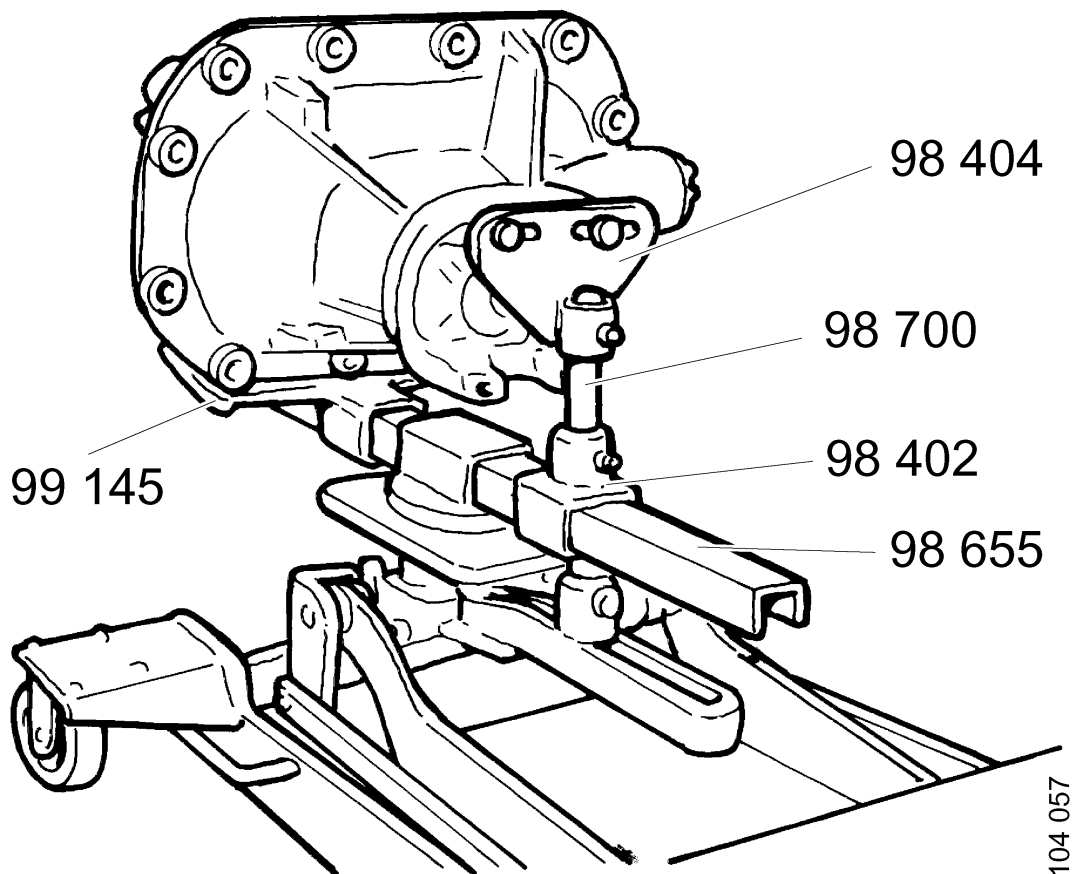

Axle beam

Assembling

Tools

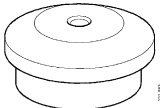
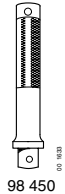
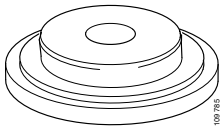
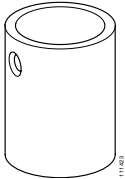
Number	Designation	Illustration	Tool board
87 441	Drift		AM1
98 450	Shank		AM1, AD/AS2, R2
99 191	Drift		G4
99 005-1	Pusher adapter		H1

- 1 Fit the sleeve and tap the bearing into the axle beam using 87 441 and 98 450 and fit the snap ring.

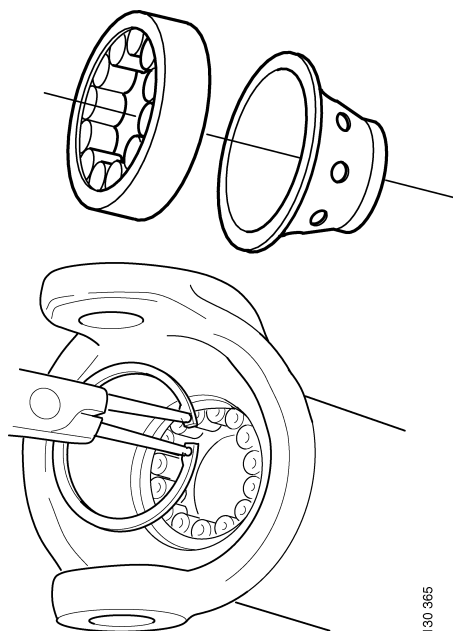

- 2 Lubricate the holder for the sealing ring. Press the inner sealing ring carefully into the sealing ring retainer and then the outer sealing ring using the tool as shown in the picture.

Note: Ensure that the sealings are correctly turned (see picture).

- 3 Fit a well oiled O-ring on the sealing ring retainer and tap it into the axle beam using drift 87 441 and shank 98 450.
- 4 Fill with axle gear oil up to the hole in the sleeve.
- 5 Smear a bearing with grease and make sure that it is evenly distributed around the sealings.

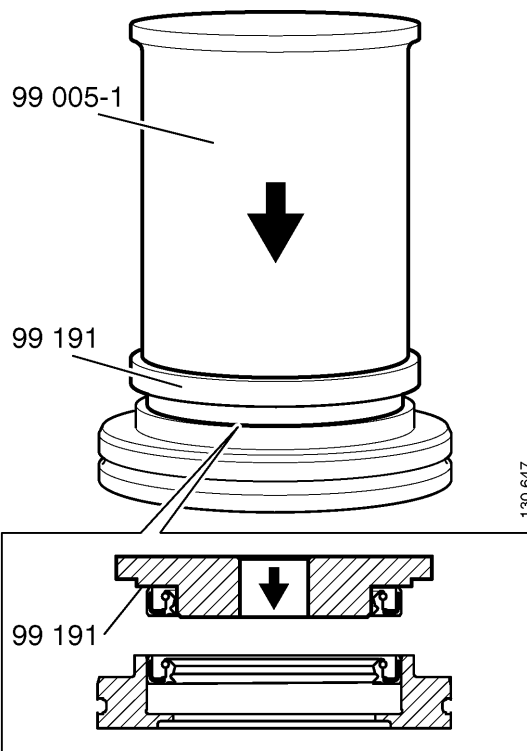

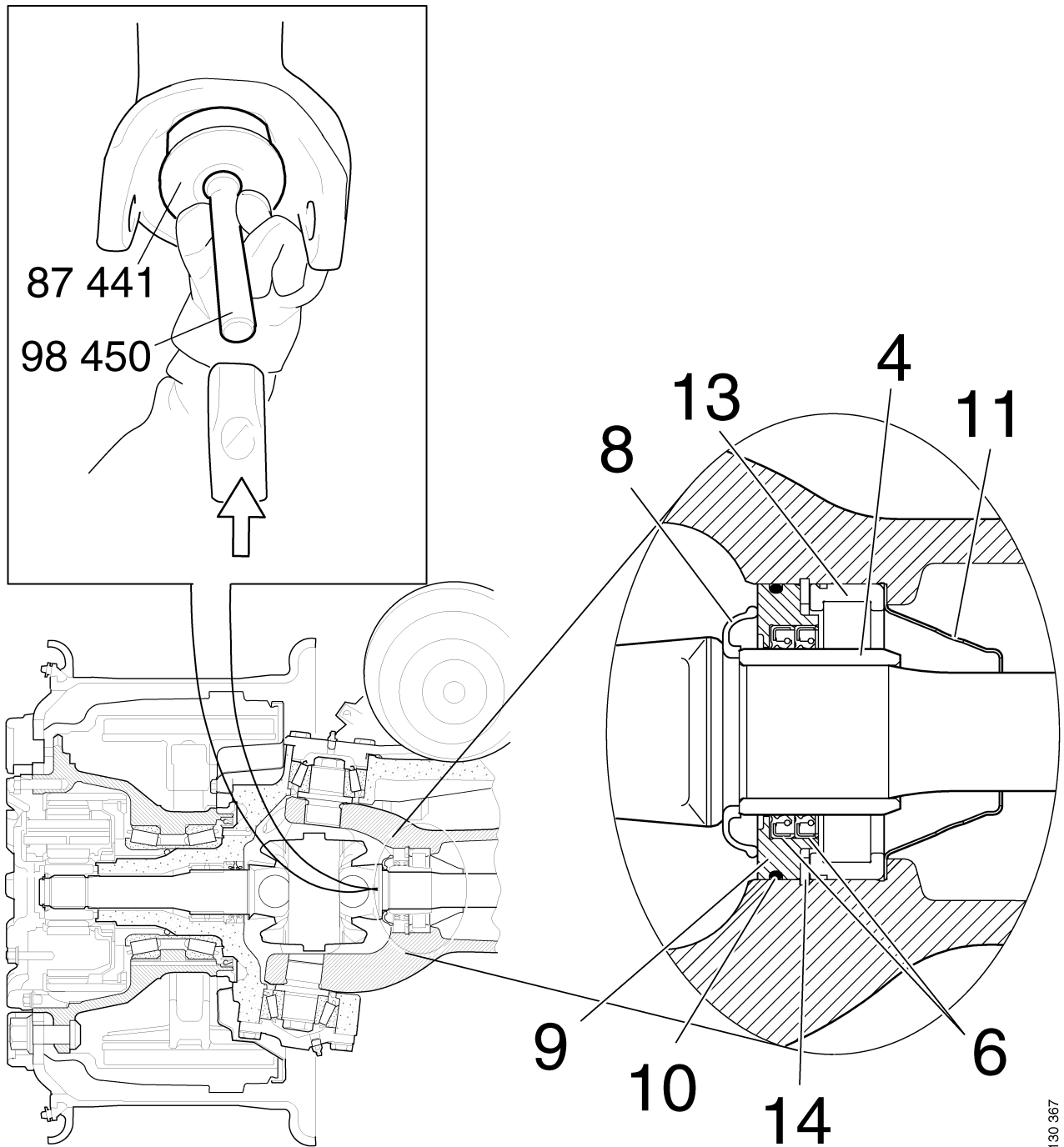

130 367

Half shaft

Assembling

General

Adhesive

816 064

Tools

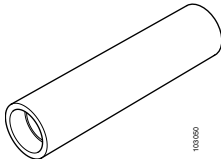
Number	Designation	Illustration	Tool board
99 352	Assembly sleeve	99352 	AM3

- 1 Fit the dust cover to the half shaft joint, on the inner part of the half shaft. Glue the sealing with adhesive 816 064.
- 2 Fit the bearing races on the half shaft using 99 352.

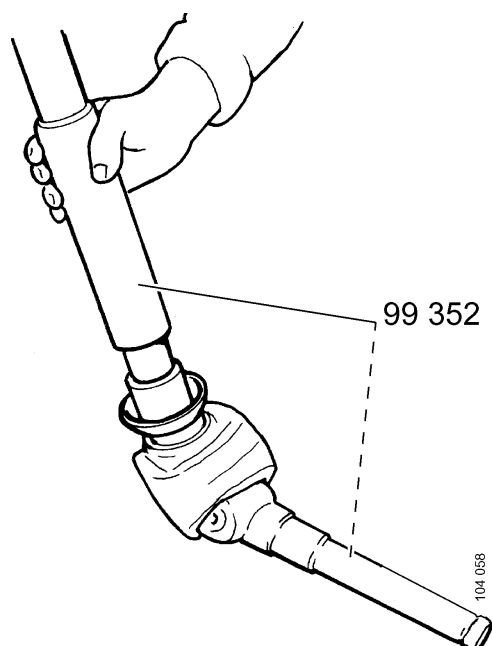

- 3 Fill the space between the dust cover and the sealing ring retainer with grease, see picture.

Note: Feel with a finger whether the bearing rollers sit correctly in the bearing in the axle beam.

- 4 Apply the differential lock using compressed air and push the half shaft into the axle beam.

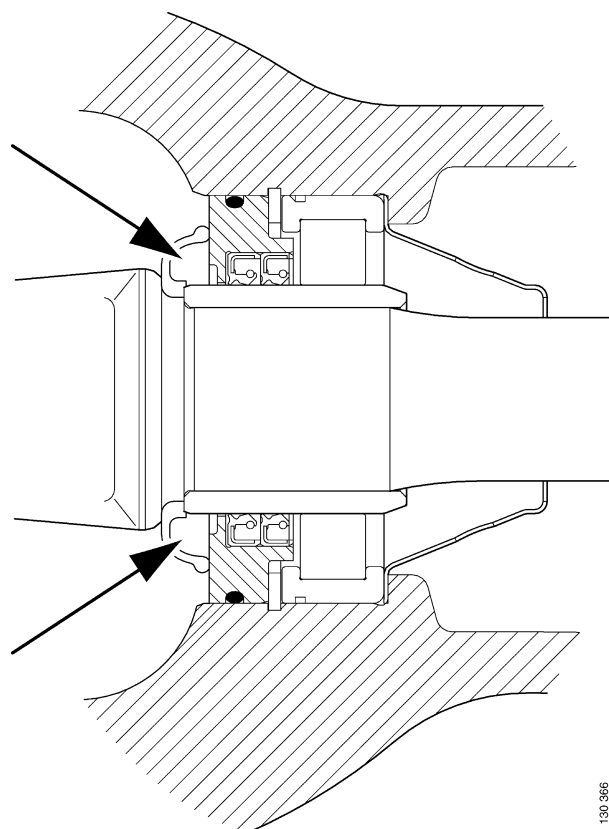

130 966

Shaft journal

Assembling

Specifications





General

Locking compound

Part No.

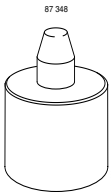
561 200

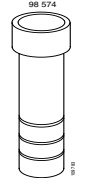
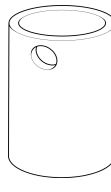
Tools

Number	Designation	Illustration	Tool board
87 348	Drift		AM1
87 579	Drift		R1
98 574	Drift		R1
99 477	Drift		AM3
587 588	Spring balance		A

- 1 Press the half shaft bearing outer race onto the shaft journal using drift 99 477.
- 2 Fit the snap ring.
- 3 Press carefully on the first sealing using drift 99 477.
- 4 Lubricate the sealing ring retainer and press in the sealing ring by hand.

Note: Make sure that the sealings are correctly turned.

- 5 Press the sealing ring retainer into the shaft journal using 99 477.
- 6 Smear a bearing with grease and make sure that it is evenly distributed around the sealings.

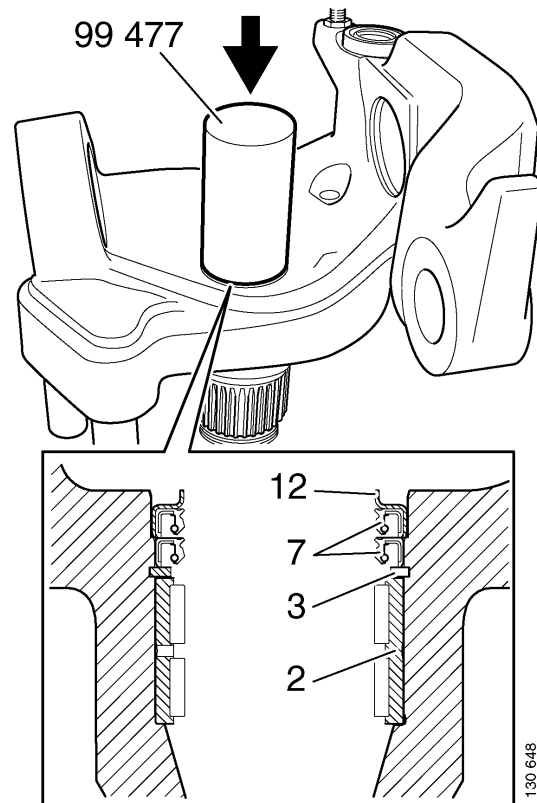

- 7 Press the sealing rings for the swivel pins onto the shaft journal by hand.

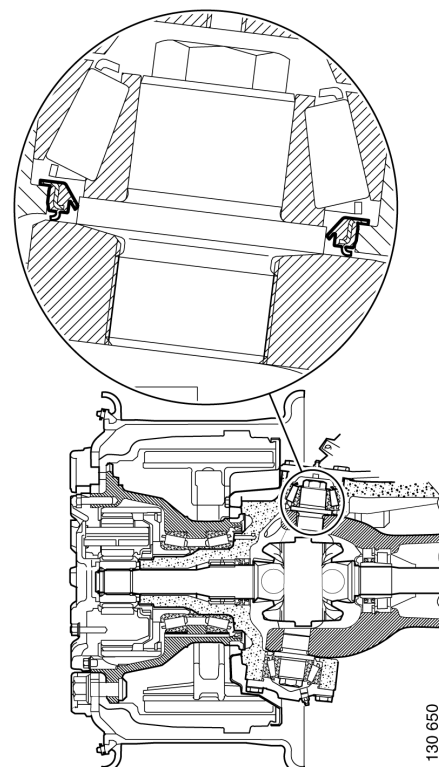

- 8 Press the bearing inner races onto the swivel pins using drift 98 574.
- 9 Lift the stub axle and feed the half shaft into the stub axle.

Note: Take care not to damage the sealings.

- 10 Push the shaft journal carefully into place.
- 11 Apply locking compound 561 200 to the thread.
- 12 First fit the upper and then the lower swivel pin.

Note: Take care not to damage the threads.

- 13 Tighten the swivel pins to 1,400 Nm.

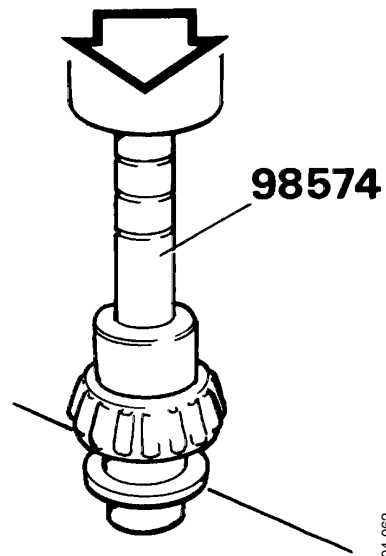

- 14 Fit the springs and the swivel pin bearing outer races using drift 87 579.
- 15 Fit the old shims on the upper bearing outer race. Fit the oiled O-rings and tighten the brake chamber bracket and the lower cover to 135 Nm.

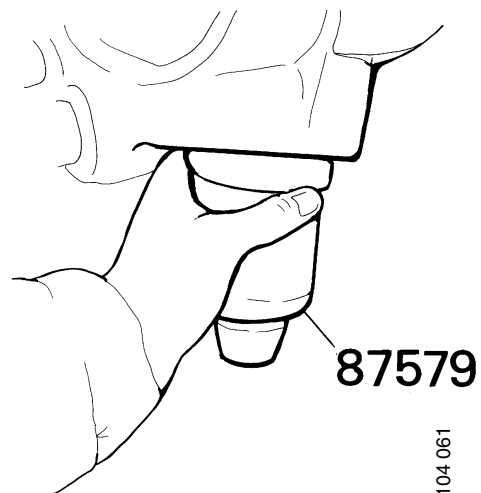

16 Fit a spring balance to the track rod bracket. Check that resistance to rotation is around 130 N. Adjust where necessary by adding or removing shims from the upper swivel pin.

- Shims are available in thicknesses: 0.10, 0.178, 0.25, 0.50 and 1.0 mm.

17 Fit the track rod and the drag link. Tighten the ball joint nuts to 250 Nm and further to the next hole. Lock using a split pin.

18 Fit brake shield, brake camshaft and brake chamber.

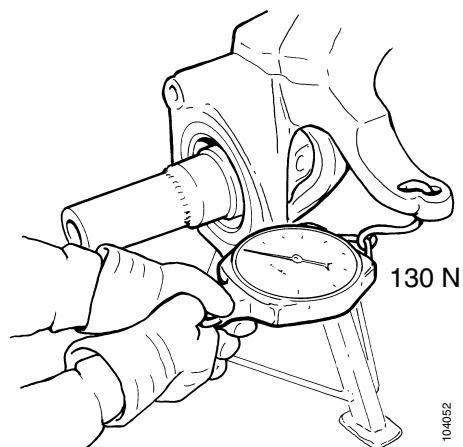



104052

Hub

Assembling

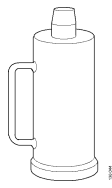
Tools

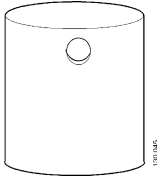
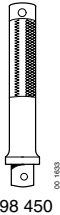
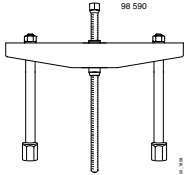
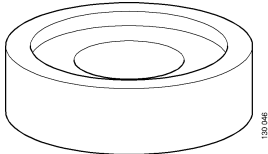
Number	Designation	Illustration	Tool board
87 550	Drift		AD2
98 075	Dial gauge		D2
98 364	Assembly drift		R1
98 450	Shank		AM1, AD/AS2, R2
98 590	Puller		AD1
99 120	Pressplate		AM1

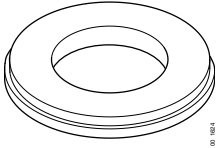
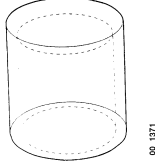
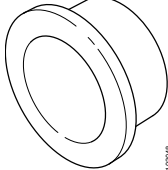
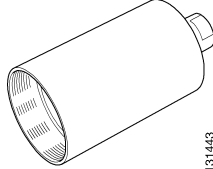
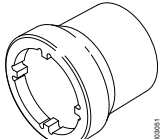
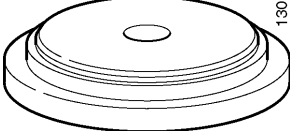
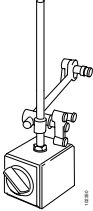
Number	Designation	Illustration	Tool board
99 142	Support ring		PT1
99 147	Drift		
99 350	Adapter for wheel bearing setting		AM3
99 351	Sleeve for wheel bearing setting		AM3
99 353	Special sleeve		AM3
99 476	Drift		AD/AS4
587 250	Indicator stand		A

- 1 Fit the protective plate on the inside of the inner bearing inner race. Turn it in the correct orientation as shown.
- 2 Check the venting.
- 3 Fit the inner wheel bearing on the shaft journal using drift 87 550.

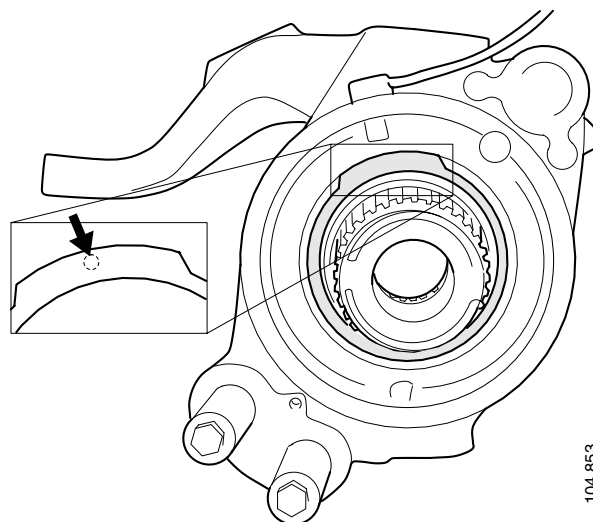

104 853

- 4 Press the outer races into the wheel hub using the tool as shown in the pictures.

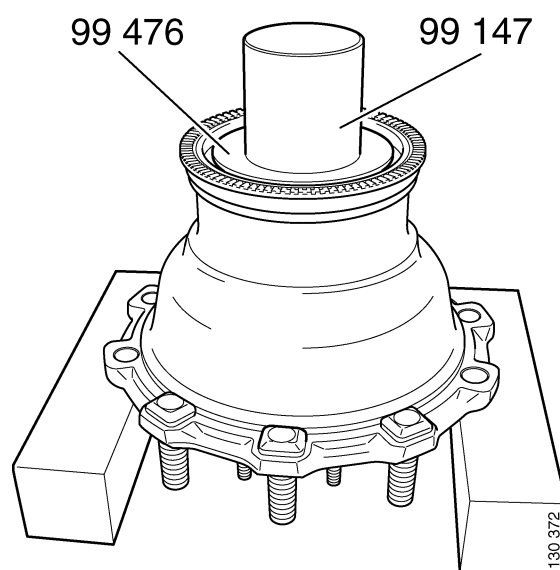

130 372

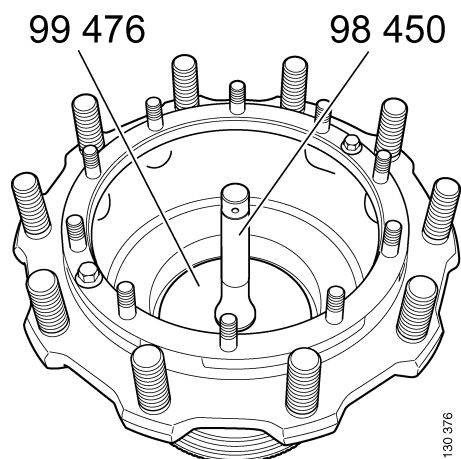

130 376

- 5 Press on the ABS gear wheel using drift 99 142 and 99 283, if it was removed.
- 6 Fit 4 x 1.3 mm shims to the shaft journal. The shims' total thickness should be at least 5.2 mm to always provide a measurable bearing play. Fit the spacing sleeve and an O-ring to hold the sleeve in place.

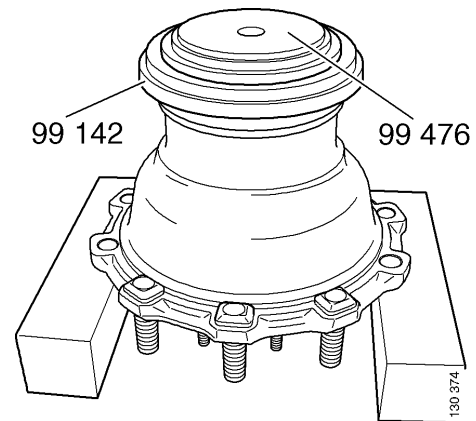

- 7 Fit the inner race to the adapter 99 350.

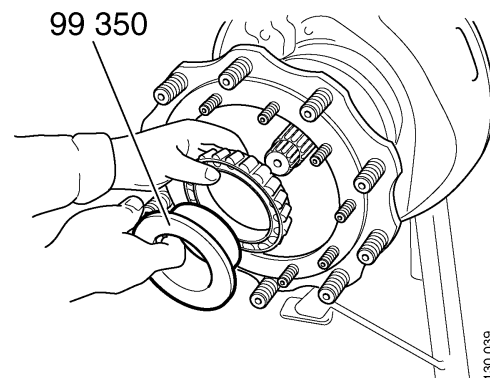

- 8 Fit the wheel hub using the tool as shown in the picture.
- 9 Fit the bearing and the adapter instead of the ring gear retainer.

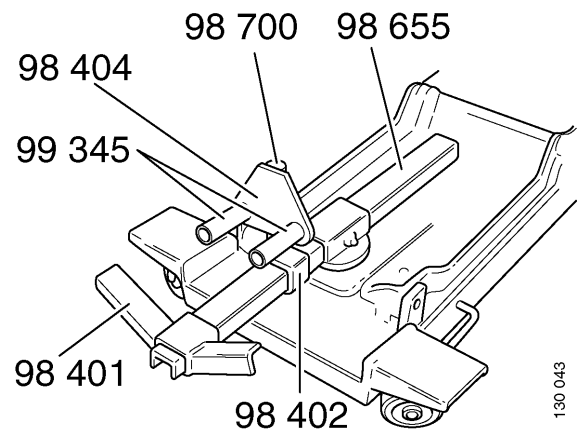

- 10 Oil the shaft journal thread and thread on the hub nut. Tighten the nut to 400 Nm using splined socket 99 353. Rotate the hub at least 5 rotations and continue to tighten, with the hub rotating, to 900 Nm.

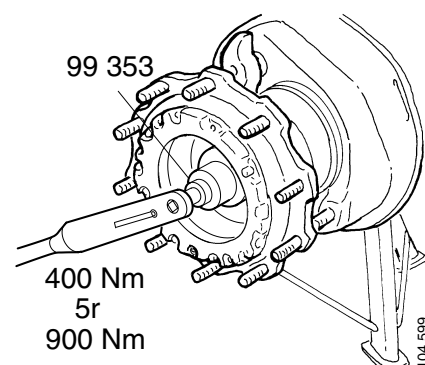

- 11 Fit the indicator stand to the hub as shown in the picture, with the dial gauge against the end plate on 99 351.
- 12 Set up tool 98 590 as shown in the picture.
- 13 Tighten the puller bolt clockwise to 20 Nm. Rotate the hub 5 rotations. Zero the dial gauge. Mark the measurement point on 99 351.

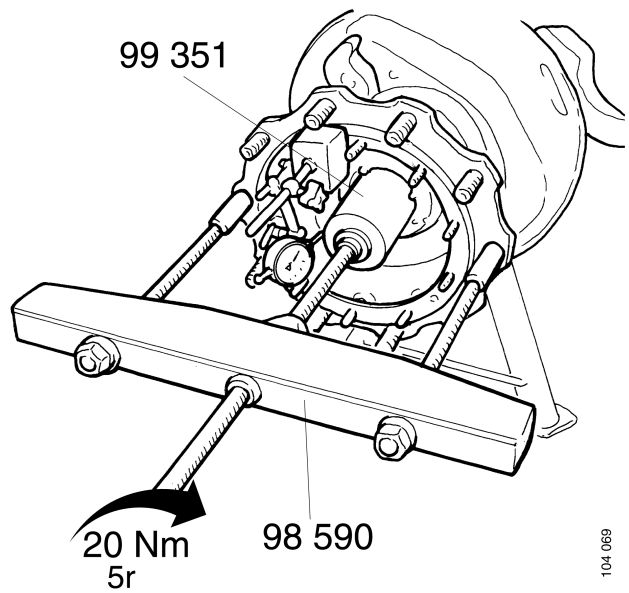

- 14 Tighten the puller bolt anticlockwise to 20 Nm. Rotate the hub 5 rotations. Turn the hub so that dial gauge tip is in the same position as when it was zeroed. Read the dial gauge.
- 15 Remove the tool, the adapter and the hub. Reduce the thickness of the washer assembly by the value read on the dial gauge, the bearing play. Reduce a further 0 - 0.10 mm to obtain the correct bearing preload. Try to get as close to 0.10 mm bearing preload as possible.

- Shims are available in thicknesses: 1.00, 1.05, 1.20 and 1.30 mm.

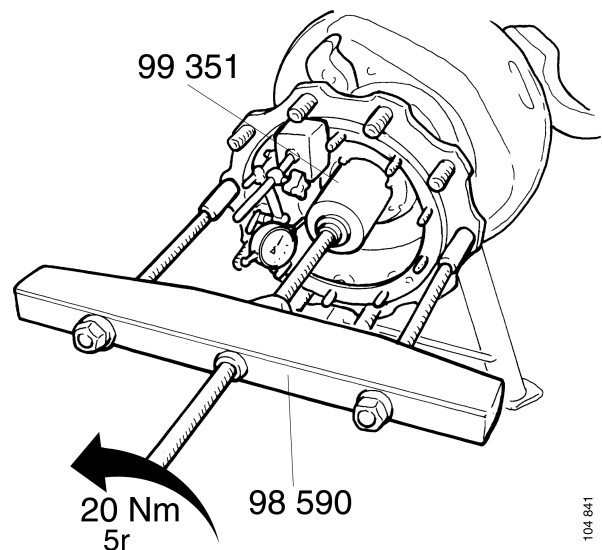

- 16 Press the bearing onto the ring gear retainer using tool as shown in the picture. Centre the tool precisely.
- 17 Assemble the internal ring gear and the ring gear retainer.

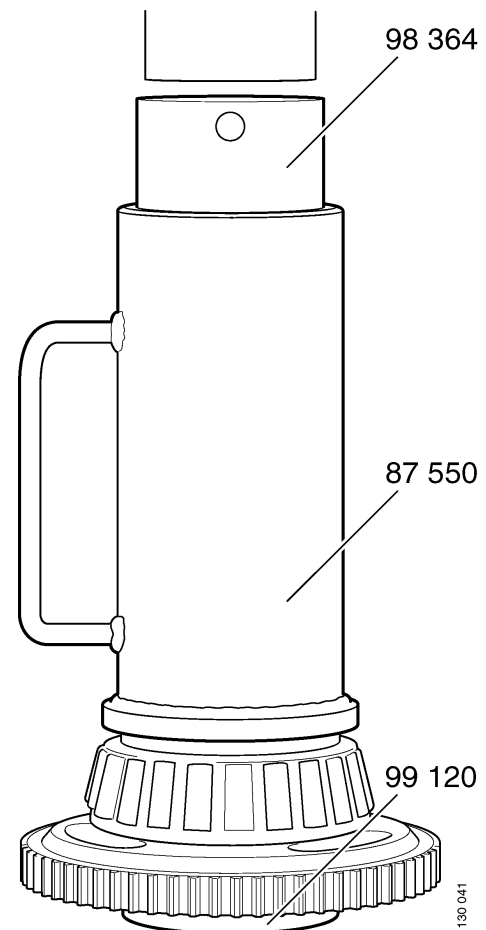

- 18 Turn the sealing ring with the text 'oil side in' and press the sealing ring into the hub using the tool and as shown in the picture.
- 19 Fit the four wheel studs which were removed when dismantling.
- 20 Lubricate the sealing ring inside diameter with oil.

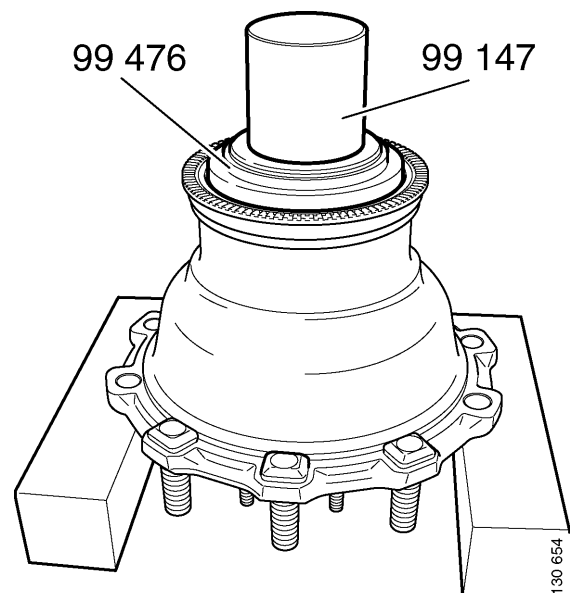

- 21 Set up the hub using the gearbox jack, as shown in the picture. Fit it in onto the shaft journal.

Note: Take great care so that the sealing ring is not damaged. The gearbox jack is used to reduce the risk of damaging the sealing.

- 22 Oil the shaft journal splines and threads. Fit the ring gear retainer with internal ring gear and thread the hub nut on by hand, as far as it will go.

- 23 Remove the gearbox jack.

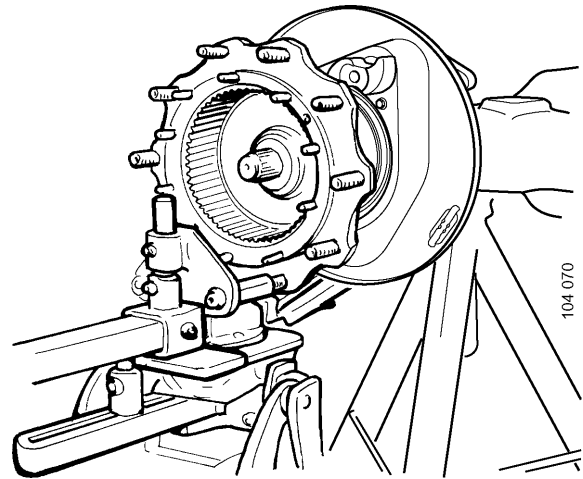

- 24 Tighten the hub nut to 400 Nm using splined socket 99 353. Rotate the hub at least 5 rotations and tighten, with the hub rotating, to 900 Nm.

- 25 Lock the hub nut by upsetting it on three points in the hole on the ring gear retainer.

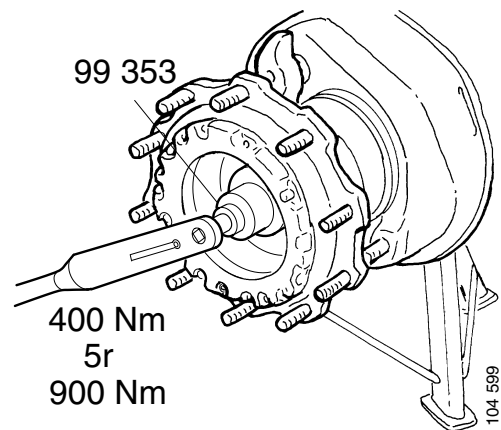

- 26 Fit wire ring 27, thrust washer 24, sun wheel 19, thrust washer 26 and snap ring 31.

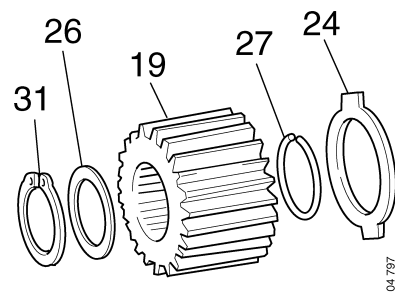

- 27 Fit an oiled O-ring to the planetary unit.
- 28 Fit the planetary unit (note the hole for oil filling and level) with cones and nuts. Tighten the nuts crosswise to 87 Nm.
- 29 Fit an oiled gasket to the cover.
- 30 Fit the thrust washer and cover and tighten the bolts crosswise to 39 Nm.
- 31 Turn the hub until the cover marking line 1 is in a horizontal position.
- 32 Fill with oil in oil filler hole 2 to the lowest level hole 3.
- 33 Fill the puller hole threads halfway with grease and press in the protective plugs.
- 34 Fit the remaining brake components and adjust as described in the workshop manual 10:02-06.
- 35 Fit the wheel and tighten the wheel bolts as described in the workshop manual 09:00-01. Lower the axle.

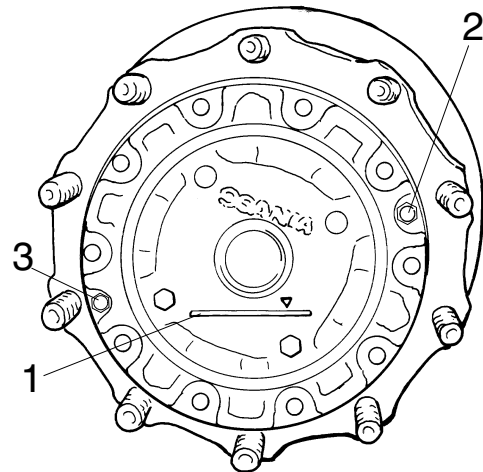

104 858

Specifications

General

Oil volume RP731	13.5 litres
Oil volume, hub reduction gear	0.8 litres
Oil type	Refer to Group 0.
Sealing compound for axle beam	816 064
Adhesive for dust cover	816 064
Locking compound	561 200

Settings and test values

Torque, shaft journal	130 N
Preload, wheel bearing	0.00 - 0.10

Tightening torques

Hub nut	400 Nm and up to 900 Nm
Nuts for central gear	300 Nm
Studs in axle beam	80 Nm
Swivel pins	1400 Nm
Bracket, brake chamber	135 Nm
Lower swivel pin cover	135 Nm
Ball joints, shaft journal	250 Nm and then on to the closest hole
Planetary unit nuts	87 Nm
Hub cover	39 Nm
Bolts for anti-roll bar bracket on axle	350 Nm
Nuts for front bracket for anti-roll bar	180 Nm
U-bolt nuts	See tightening diagram in service literature 12:01-01