

SCANIA

08:06-51

Issue 1.1 en

Tag axle ASA701

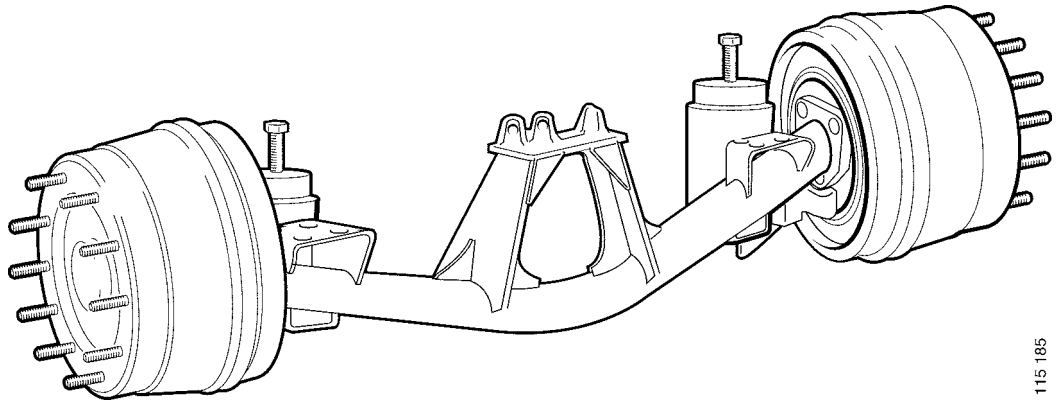

115 185

Tag axle ASA701

Brakes

For work on the brakes, see Workshop manual group 10, "Wheel brake components, function and work description".

General

ASA701 is an air suspended tag axle designed for a bus with a maximum axle weight of 7.5 tons.

The tag axle consists of a bent steel pipe with welded brackets. It uses the same hub as the front wheel hub. The brake components are also taken from the front axle.

Mounting

Tag axle attachment, see the description in Workshop manual group 12, "Air suspension, mechanical parts (bus)".

Hub

For work on the hub, see Workshop manual group 9, "Front wheel hub, function and work description".

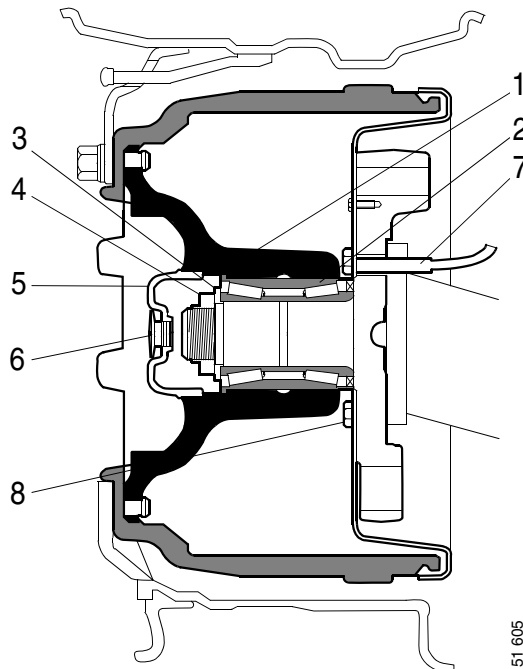

- 1 Hub
- 2 Bearing
- 3 Spacing washer

- 4 Hub nut
- 5 Hub cap
- 6 Plug

- 7 ABS sensor
- 8 Bolt 270 Nm

151 605