

SCANIA

08:06-52

Issue 1 en

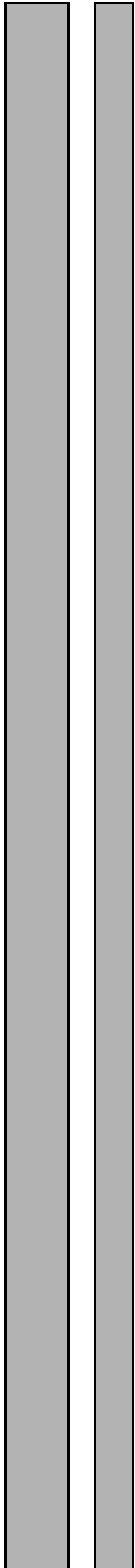

Tag axle ARA860

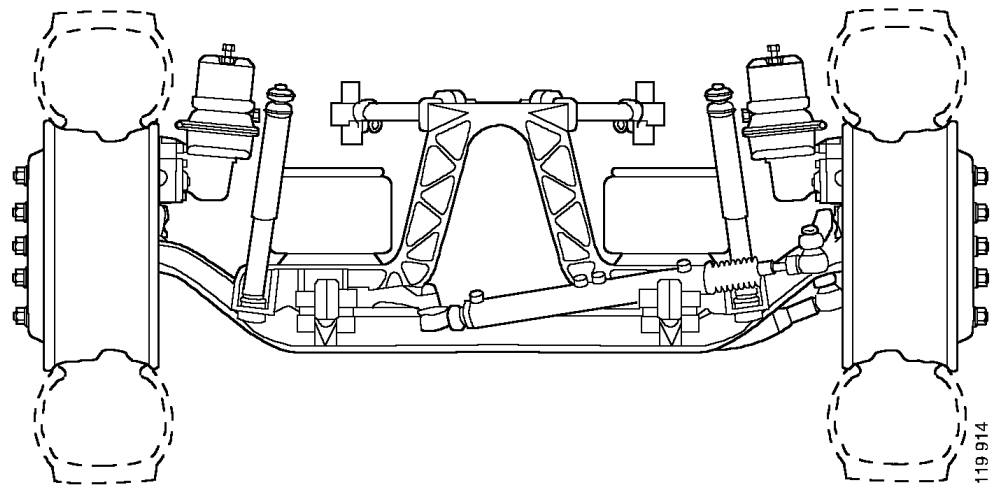

119 914

1 712 806

Tag axle ARA860

General

ARA860 is an air suspended steered tag axle for buses and it has a maximum axle load of 7.5 tonnes.

For adjusting wheel angles, see group 13, Adjusting wheel angles, steered tag axle ARA860.

The tag axle is a modified AMA860 that has been equipped with a bracket to allow mounting of air bellows and torque rods. The tag axle hub is of the same type as the front wheel hub, and the brake components have also been taken from the front axle.

Hub

When working on the hub, see instructions in Workshop manual group 9, Disc brake hub, front axle.

Steering

When working on the hydraulic steering system, see instructions in Workshop manual group 13, ARA860 Steered tag axle behind the driving axle.

Brakes

When working on the brakes, see instructions in Workshop manual group 10, Wheel brake components.

Mounting

The axle mounting in the chassis and its measurements are the same as for ASA701. The two upper torque rods can be adjusted by loosening a clamp joint and turning the tube. If work is carried out, see instructions in Workshop manual group 12, Wheel brake components.