

**SCANIA**

**10:02-57**

Issue 1 **en**

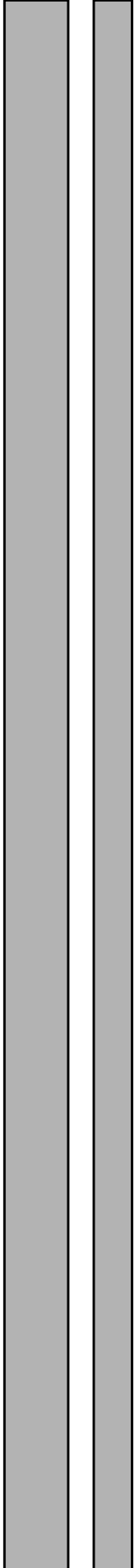

## **Compressed air lines for buses**

# Contents

Safety .....	3
Work Description	
Material .....	4
Marking.....	4
Union nut and ferrule.....	5
Bend radii.....	6
Renewing quick-fit couplings.....	6
Connections for steel pipes .....	7
Renewing rubber hoses.....	8

# Safety



**WARNING!**

**Work on the brake system may only be carried out by personnel with the requisite training and skills for the task. If problems nevertheless occur, your immediate superior must be requested to help.**

**When carrying out any work on the brake system, it is important to follow the instructions carefully so as to avoid accidents and personal injury.**

**It is also important to use the right components at all times when working on the brake system. A defective brake system due to defective components can have disastrous consequences on the road.**

# Work Description

## Material

### Plastic pipes

- Most of the compressed air lines on the bus are plastic pipes. Plastic pipes are available in sizes of 6, 8 and 12 mm. Plastic pipes can be connected in two different ways:
- Using a union nut, insert sleeve and ferrule which is connected to a union.
- Using a quick-fit coupling which is connected to a union.

### Rubber hoses

- Rubber hoses are used for connections requiring good flexibility, e.g. between frame and axles.

### Steel pipes

- Anti-corrosive treated steel pipes are used for lines exposed to heat, e.g. from the engine.

### Marking of compressed air lines

- For the marking of compressed air lines, see section 10, Marking of compressed air lines.

## Union nut and ferrule

The plastic pipes (1) are connected using an insert sleeve (4), a ferrule (3) and a brass union nut (2), which is connected to a union (5) on the component.

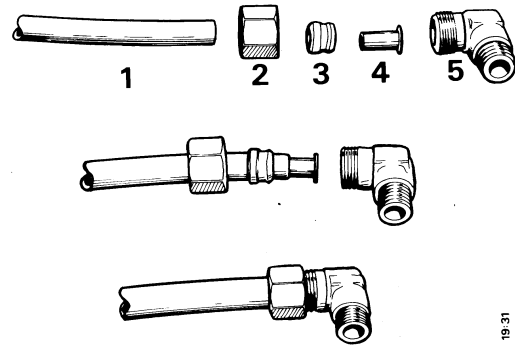

- 1 Pipe
- 2 Union nut
- 3 Ferrule
- 4 Insert sleeve
- 5 Union

### Tightening torque

- Tighten the union nut (2) to the torque as described in the table.

Pipe diameter	Tightening torque	
	With steel ferrule	With brass ferrule
6 mm	10 Nm	
8 mm	20 Nm	
12 mm		20 Nm

- These torques correspond to the nut being tightened as much as possible by hand and then an additional 1 1/2 turns with the wrench.

**Note:** For pre-fitted ferrules, the nut must be tightened 3/4 turns with a wrench. The same applies when assembling previously dismantled couplings.

## Bend radii

**IMPORTANT!** Avoid sharp bends. Kinks can occur in the pipe which restrict the air flow.

Pipe diameter	Min. inner bend radius
6 mm	35 mm
8 mm	55 mm
12 mm	95 mm

## Renewing the quick-fit couplings

**IMPORTANT!** If the pipe is to be disconnected from a component, unscrew the whole coupling from the component. The plastic pipe cannot be extracted from the coupling – it spins inside it.

- 1 Cut off the pipe.

**Note:** The pipe must be squarely cut off and must not be damaged in any way.

- 2 Dispose of the old quick-fit coupling assembly.

**Note:** The quick-fit coupling may not be reused. It constitutes one unit and may not be dismantled. If reused, the ferrule may damage the O-ring, resulting in leakage.

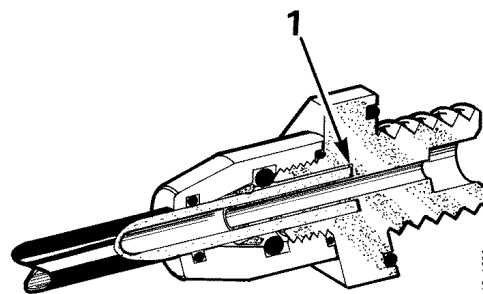

*Quick-fit coupling*

10\_1066

- 3 Install a new quick-fit coupling.
- 4 Insert the pipe into the coupling. The pipe end must reach as far as possible into the coupling (1 in the illustration).

## Connections for steel pipes

**Note:** Ferrules and steel nuts must be used for steel pipes.

Turn the collar of the ferrule (1) to face the union nut (2). See illustration.

Lubricate the rear edge of the ferrule facing the nut (at arrow in illustration), and the union thread.

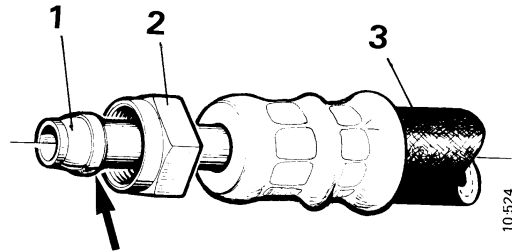

- 1 Ferrule
- 2 Union nut
- 3 Hose

### Tightening torque

- Tighten the union nut (2) to the torque as in the table.

Pipe diameter	Tightening torque
6 mm	20 Nm
8 mm	30 Nm
10 mm	40 Nm
12 mm	50 Nm
16 mm	60 Nm

- These torques correspond to the nut being tightened as much as possible by hand and then an additional 1 1/2 turns with the wrench (1 1/4 turns for 16 mm pipes). Use a dolly.
- Renew the union if the nut cannot be tightened by hand.

**Note:** When tightening connections to a union connected to a pipe, it is important that the union is not rotated. If the union is rotated, congealed sealant in the pipe thread may crack causing leakage.

## Renewing rubber hoses

To avoid damage to the rubber hoses, they must be the right length and may not be twisted.

Note the following when renewing brake hoses:

- The wheels must be in straight ahead position.
- First, fit the hose to the frame connection.
- Allow the hose to become straight and make sure it is not twisted, before connecting it to the cylinder.
- Do not twist the hose.

Apply the brake to check that fitting has been carried out correctly. When applying the brake, the hose may move no more than 25 mm, as illustrated.

