

# AC / ETC

## Function and work description

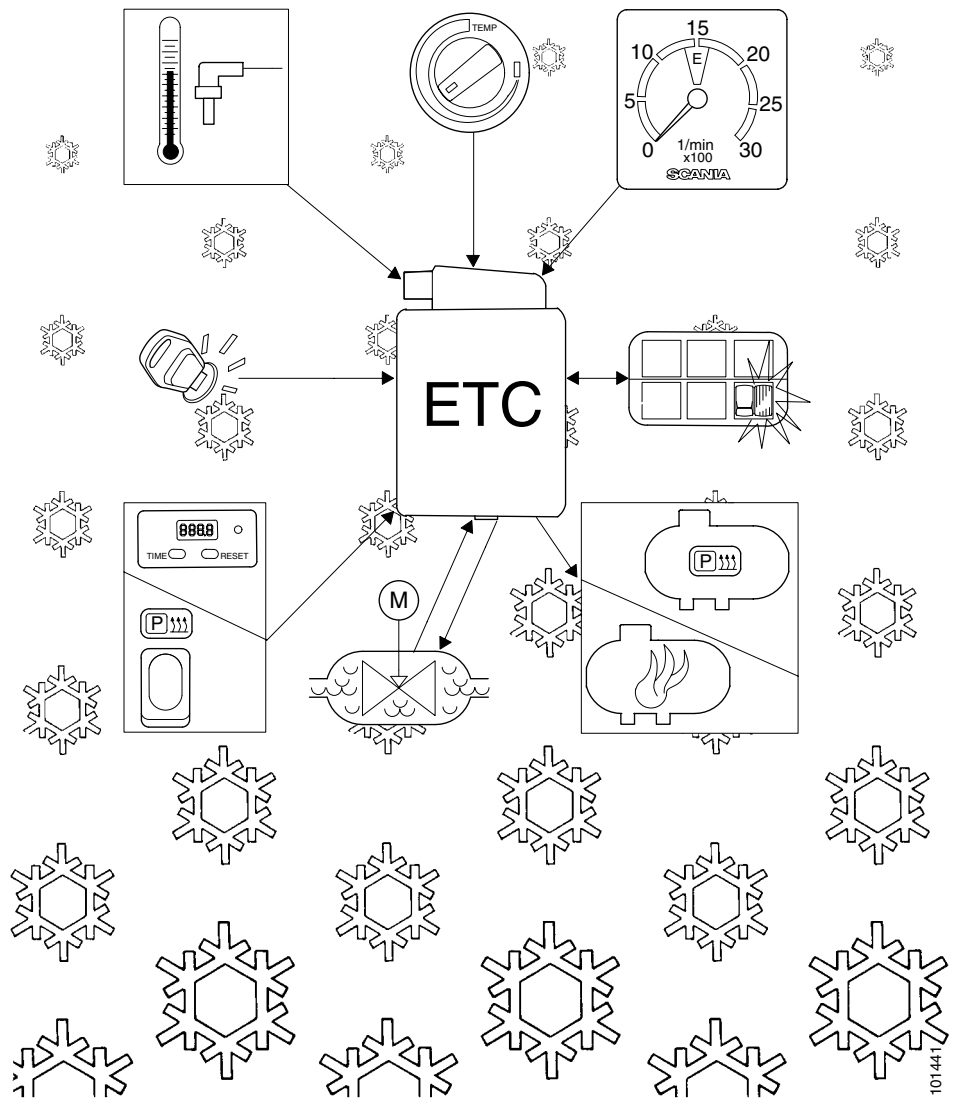

# Contents

Function Description	ETC.....	3
	Air conditioning (AC) .....	4
Work Description	Working with refrigerant .....	7
	Compressor.....	15
	Condenser .....	24
	Hoses .....	25
	Control motor .....	27
	Thermostat.....	28
	Water valve .....	29
	Dehydrator / Expansion valve .....	31
	Evaporator / Heat exchanger .....	32
	Temperature sensor.....	43
	Potentiometer.....	44
	Control unit.....	45
	Fan motor.....	46
	Fan resistor unit .....	48
	Ventilation control cable.....	49
	Temperature control cable .....	51
Troubleshooting	Equipment.....	52
	General .....	52
	Wiring Diagrams .....	52
	Troubleshooting the cooling process.....	54
	Troubleshooting without pressure gauge.....	55
	Troubleshooting with pressure gauge.....	56

# Function description

## ETC

### General

Vehicles with electronic temperature control are equipped with an electronically controlled water valve governed by a control unit. The control unit compares the set temperature with the generated temperature, correspondingly controlling the water valve. A temperature sensor, fitted immediately after the heat exchanger, is used for this purpose. Any faults detected by the control unit are indicated by flashing codes. The ETC control unit also governs the short-stop heater and the auxiliary heater (when the engine is off, the cab temperature is controlled by the auxiliary heater thermostat).

### Control in combination with AC

The ETC system is automatically controlled whereas the AC system is manually controlled. When these systems interact, the AC system operates at full capacity and the ETC can add heat to the air if it gets too cold using AC only.

## Air conditioning (AC)

### General

The main purpose of the AC system is to reduce the cab temperature to a comfortable level as compared with the ambient temperature.

The AC system also dehydrates the air entering the cab. The air is dehydrated in the evaporator, where the moisture is condensed. Then, the dry, cold air is heated by the heating system. This produces hot, dry air, which effectively removes moisture from the cab.

The AC system has a cold side and a hot side. The cold side is used for cooling the cab air and the hot side is cooled by the outside air.

On old vehicles, the AC switch has three positions: Off, AC with fresh air and AC with recirculated air. On new vehicles, the AC switch has two positions, the recirculation being controlled by a separate two-position switch.

temperature of the fins is below 0°C and closes again when the temperature reaches +4°C.

The pressure monitor is located at the condenser and ensures that the compressor only engages when the pressure is between 2 and 31.4 bar.

### Refrigerant R134a

Refrigerant R134a must never be mixed with the previously used R12. This could cause the AC compressor to seize! R12 is being replaced with R134a due to the harmful influence of R12 on the ozone layer in the atmosphere.

The refrigerant in the system has very special properties. It will easily condense and evaporate under the influence of pressure changes and temperature changes.

Also refer to the Workshop manual, group 18, Modifying the AC system for refrigerant R134a.

### Control of the compressor

The compressor clutch coil is controlled by a thermostat and a pressure monitor.

The thermostat sensor element is a capillary tube, sensing the temperature of the evaporator fins. The thermostat cuts out when the

## Cooling process

The compressor 1 increases the pressure and temperature of the evaporated refrigerant.

When the refrigerant passes the condenser 2, heat is extracted and the refrigerant is converted into liquid.

The expansion valve 4 reduces the pressure of the liquid.

The cold refrigerant, under low pressure, starts boiling in the evaporator 5, which means that the refrigerant draws heat from the air passing. The air then becomes cold. The air is either recirculated or fresh depending on the system setting.

## Components

### Compressor 1

The compressor compresses the refrigerant from 1-2 bar to 10-15 bar depending on the ambient temperature. The compressor is driven by the engine via a belt transmission and is disengaged/engaged by an electromagnetic clutch located at the pulley.

### Condenser 2

The condenser cools the hot, gaseous refrigerant, converting it into liquid.

The condenser is equipped with a resetting safety valve, which opens at 33.8-41 bar.

The pressure monitor ensures that the compressor only is engaged when the pressure is between 2-31.4 bar.

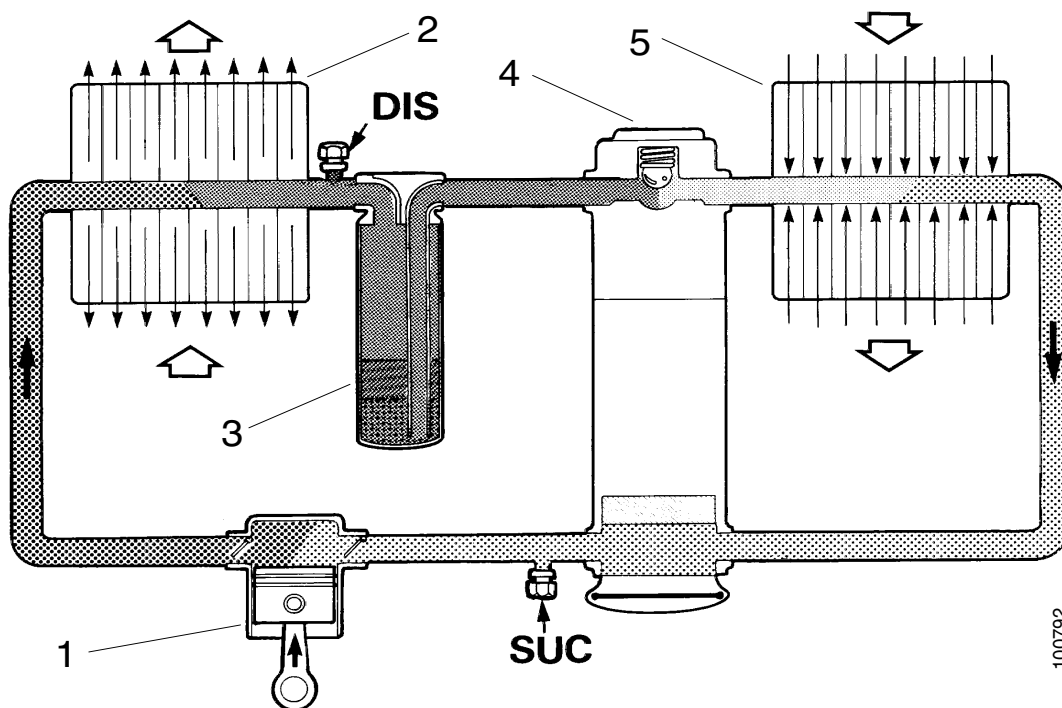

### Dehydrator 3

The dehydrator separates any moisture and impurities from the refrigerant and stores any superfluous refrigerant. On old vehicles, the dehydrator is equipped with an inspection glass.

### Expansion valve 4

The expansion valve meters refrigerant to the evaporator. The quantity depends on the pressure at the evaporator suction side and the ambient temperature. The expansion valve maintains a pressure difference between the high-pressure side and the low-pressure side. If the restriction is too narrow, the refrigerant quantity in the condenser will increase, if it is too wide, vapour will reach the evaporator.

### Evaporator 5

The liquid refrigerant draws heat from the air, the refrigerant starting to boil and being converted into gas. The thermostat, sensing the temperature of the fins, is fitted to the evaporator. The compressor engages at  $+4^{\circ}\text{C}$  and disengages at  $0^{\circ}\text{C}$ .

### Service nipples (SUC and DIS)

There is one service nipple each on the high-pressure side (DIS) and the low-pressure side (SUC). The service nipples are used when working with the refrigerant. The service nipples are of different dimensions to prevent mix-ups.

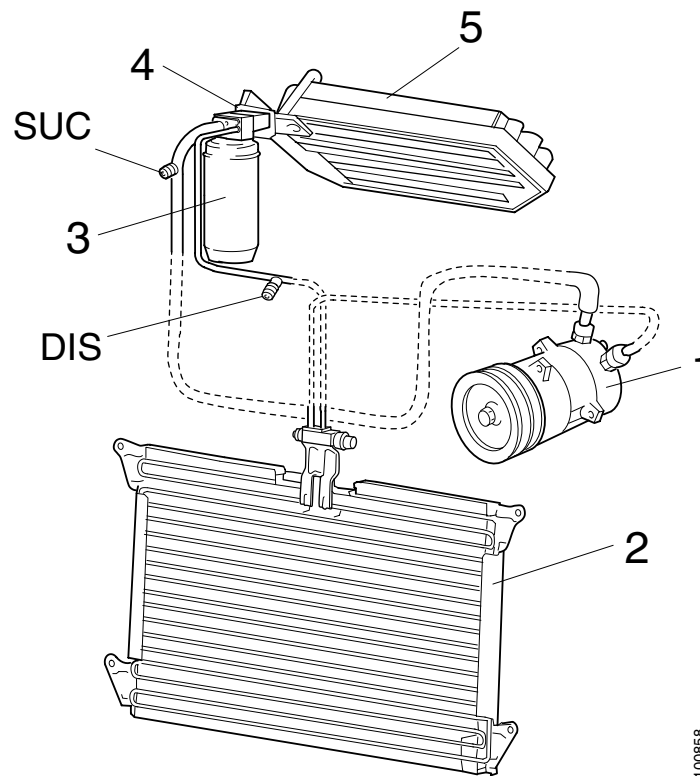

100858

*AC system components*

# Work Description

## Working with refrigerant



**WARNING!**

Always use personal protection equipment when working with refrigerant.



**WARNING!**

Seek medical attention immediately in case of refrigerant contact with the eyes. **DO NOT RUB!** Flush immediately with plenty of water, preferably running water.



**WARNING!**

Welding, smoking or heating are not allowed if there is refrigerant present in the air. The refrigerant generates a very poisonous gas when heated.



**WARNING!**

Work on the air conditioning system must be carried out in compliance with the legislation of the country in question.

## Special tools

Number	Description	Illustration	Tool board
--------	-------------	--------------	------------

587 627	Recycling station		---
---------	-------------------	--	-----

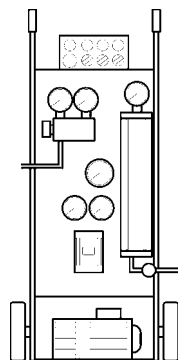

## Draining

An AC system is highly sensitive to moisture. When the refrigerant circuit is opened, the connections must be plugged as soon as possible. Always renew the dehydrator if the system has been open.



**WARNING!**

**Wear protective gloves and goggles!**

- 1 Remove the protection caps from the service nipples and connect recycling station 587 627 to the high-pressure and low-pressure sides. The service nipples are of different dimensions and thus different size quick release couplings must be used. Wear protective gloves and goggles!
- 2 Drain the refrigerant slowly to prevent too much oil from escaping along with it. The refrigerant must not be released into the atmosphere but must be recycled!
- 3 When the system is opened for renewing a defective component, the connections must be plugged immediately to prevent moisture from entering the AC system.

**IMPORTANT!** If the AC system refrigerant circuit has been open for some reason, clean the AC system from moisture-damaged compressor oil and renew the dehydrator.

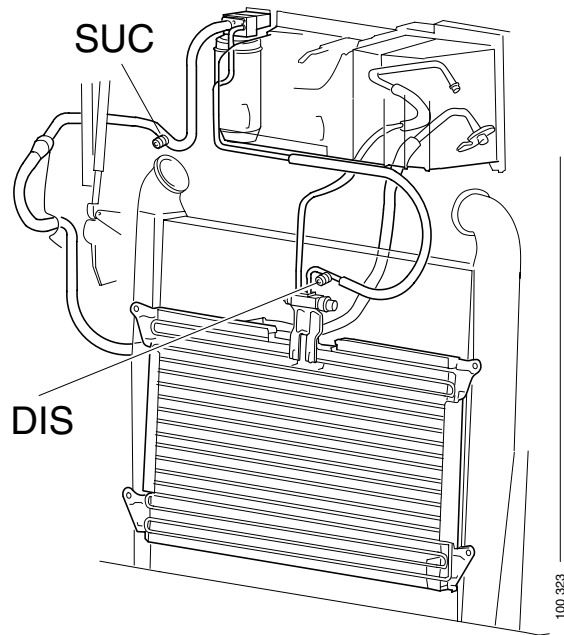

*Hose routing and service nipples, version 1*

*SUC = low-pressure side*

*DIS = high-pressure side*

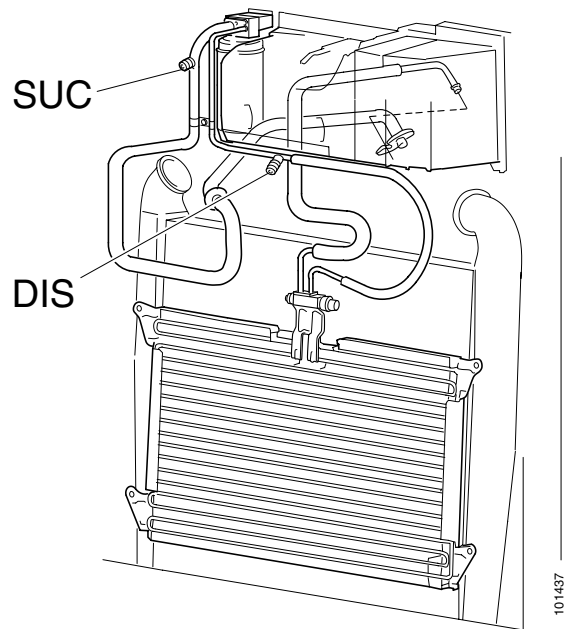

*Hose routing and service nipples, version 2*

*SUC = low-pressure side*

*DIS = high-pressure side*

## Refilling

**IMPORTANT!** Always renew the dehydrator when the AC system has been opened.

Before refilling the AC system with refrigerant, check the compressor oil quantity, refer to Compressor oil, and remove moisture by vacuum pumping, refer to Vacuum pumping. The vacuum pressure will cause all moisture to evaporate and prevent ice blockages.

## Filling refrigerant

**IMPORTANT!** Only refill using refrigerant R134a. The use of other refrigerant will cause serious damage to the AC system. Always renew the dehydrator when the AC system has been opened.

- The AC system **cannot** be refilled with the quantities stated on the marking label. This is due to the fact that some refrigerant is always dissolved in the compressor oil.
- The amount of refrigerant dissolved in the compressor oil will vary but is normally 10 to 30 %. This quantity must be deducted from the weight stated on the marking label.

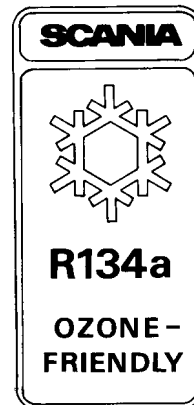

## Inspection glass method

**Note:** This method can be used on old vehicles equipped with inspection glass and will provide an optimum quantity of refrigerant provided that it is used correctly.

- 4 Refill the calculated quantity of refrigerant on the low-pressure side. A system with a specified filling quantity of 1450 g should be filled with 1000 g of refrigerant.
- 5 Start the engine. Increase engine speed to 900 - 1000 rpm. Switch on the AC system.

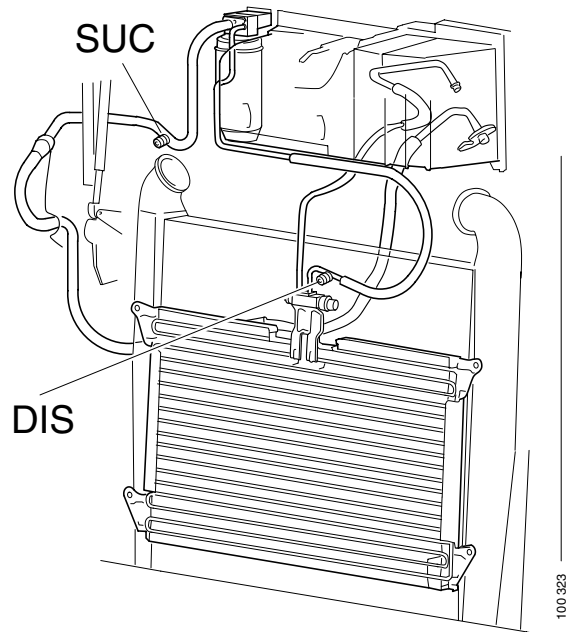

*Hose routing and service nipples, version 1*  
*SUC = low-pressure side*  
*DIS = high-pressure side*

- 6 Observe the refrigerant through the inspection glass on top of the dehydrator. Use a lamp and a dentist's mirror.
- 7 If bubbles are visible while the compressor is running, refrigerant must be added. If so, add 50 g at a time. When the refrigerant appearance changes from bubbly to clear, the refrigerant quantity is correct.

**Note:** Do not overfill! Too much refrigerant will inhibit evaporation, causing reduced cooling capacity.

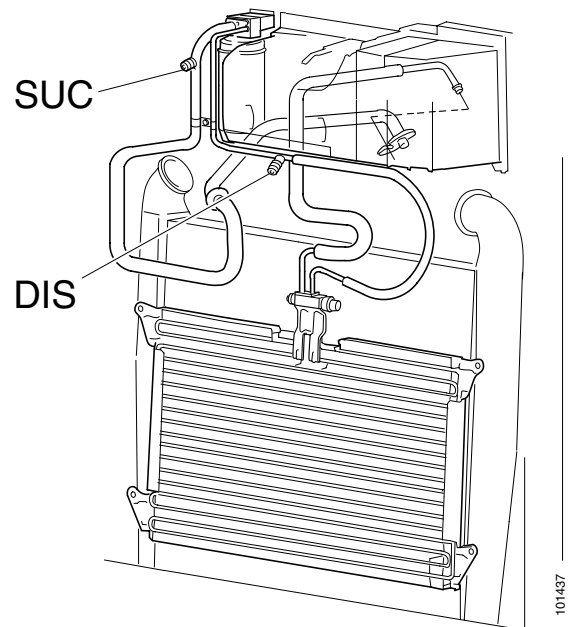

*Hose routing and service nipples, version 2*  
*SUC = low-pressure side*  
*DIS = high-pressure side*

## Compressor oil

It is very difficult to check the compressor oil quantity since the compressor oil is dispersed throughout the entire AC system.

**IMPORTANT!** Only use approved compressor oil. Compressor oil will absorb moisture very easily and thus may only be stored for a short period of time. Do not return unused oil into the container.

A new compressor is filled with approximately 240 ml oil on delivery. The system will not be damaged if operated with slightly too much oil, 80 - 100 ml. The AC system capacity will be somewhat reduced and the pressure in the AC system will rise slightly. It is far worse to operate the system with too little oil since it may cause serious damage to the compressor.

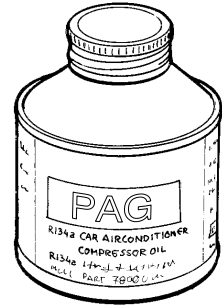

*The compressor oil is very sensitive to moisture. An opened oil container must not be resealed for later use. It must be discarded.  
Part no. 584 110*

## Oil quantity

The total oil quantity in the entire system is 240 ml. In order to achieve the correct oil quantity in the system, oil must be added or drained when working on the AC system. Add or drain oil as follows.

### Oil quantity when draining refrigerant

- Fill up with the same oil quantity as that collected in the oil container of a recycling station with oil separation.
- Fill up with 10 ml of oil if the recycling station is not equipped with oil separator.

### Oil quantity when rapidly draining refrigerant

- 1 If the AC system is damaged, causing leakage, the refrigerant will rapidly escape from the system. Most of the oil will also escape along with the refrigerant. Refill oil as follows:
- 2 Remove the compressor.
- 3 Remove the sealing plugs from the compressor.
- 4 Turn over the compressor and drain the oil. Rotate the compressor shaft in order to remove as much oil as possible.
- 5 Fill up the compressor with 160 ml new compressor oil.
- 6 Fit the sealing plugs and refit the compressor.

### Oil quantity when renewing the compressor

- 1 A new compressor is filled with 240 ml oil. Since this equals the quantity for the entire system, some oil should be drained from the new compressor. Calculate the quantity of oil to be drained from the compressor as follows before fitting the compressor.
- 2 Remove the sealing plugs from the old compressor.
- 3 Turn over the compressor and drain the oil into a measuring cylinder. Rotate the compressor shaft in order to remove as much oil as possible.
- 4 Measure the quantity of oil drained from the compressor, Y ml.
- 5 Calculate the quantity of oil, Q ml, to be drained from the new compressor according to the formula  $Q = 240 - Y$ . If 115 ml of oil has been drained from the old compressor,  $240 \text{ ml} - 115 \text{ ml} = 125 \text{ ml}$  shall be drained from the new compressor before fitting it.

## Oil quantity when renewing a component

- When renewing one of the AC system components, fill up with oil quantity according to the table.

AC component	Oil quantity (ml)
Condenser	35
Dehydrator	21
Evaporator	20
Expansion valve	1
Hose 1	13
Hose 2	2
Hose 3	13
Hose 4	8

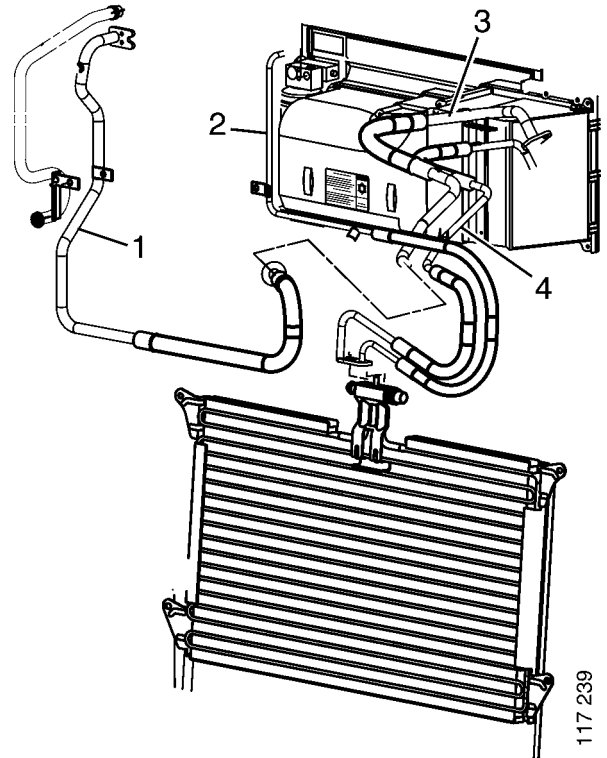

## Vacuum pumping

- Vacuum pump the system for minimum 30 minutes so as to evaporate all moisture. Otherwise, there is a great risk of ice blockages.
- Move the hoses slightly and check that the pressure does not rise. If the pressure does not rise by more than 10 mbar after 5 minutes, the AC system seal integrity is OK as regards vacuum. Then, check the filled system for leaks.

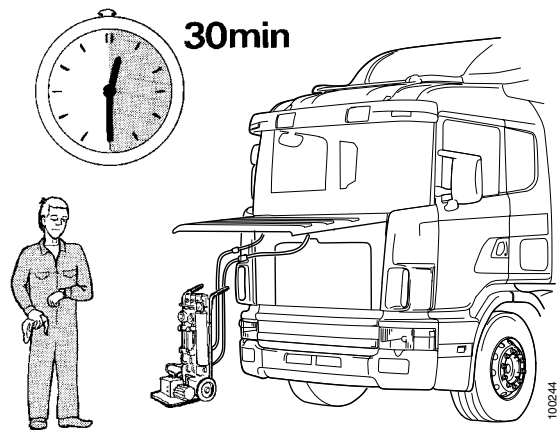

## Leak tracing

- Leak tracing of the AC system may be performed in several ways, e.g. using leakage spray or electronic leak detectors.
- Leak tracing may also be performed using leak detector 588 184, which uses tracer dye as well as UV light.
- The method described below is intended for old type electronic leak detector 587 603, requiring calibration. Leak detector 587 906 is a new type, requiring no calibration. Otherwise it operates in the same way.
- Perform the leak tracing with the engine off to prevent the cooling fan from blowing refrigerant away from the source of the leakage.

**IMPORTANT!** Vacuum pump before filling up refrigerant.

- 1 Fill with 200 - 300 g refrigerant. The pressure will be approximately 5 bar.
- 2 Switch on the leak detector at some distance from the vehicle.
- 3 Condition the leak detector to the ambient air by adjusting the sensitivity until it stops beeping.
- 4 Move closer to the vehicle and check for leaks at hose couplings and at the compressor shaft seal.
- 5 If the leak detector starts beeping before you reach the vehicle, condition it to the air close to the vehicle by reducing the sensitivity. Continue the procedure until you are close enough to locate the source of the leakage.

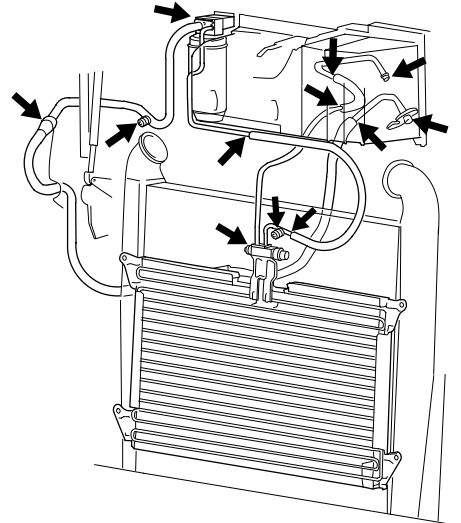
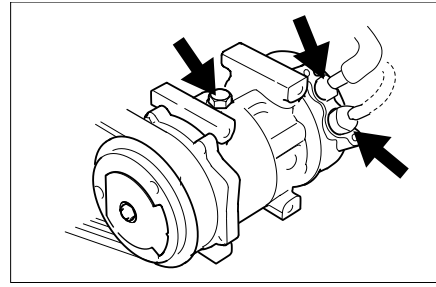

100784

*Leakage points, version 1*

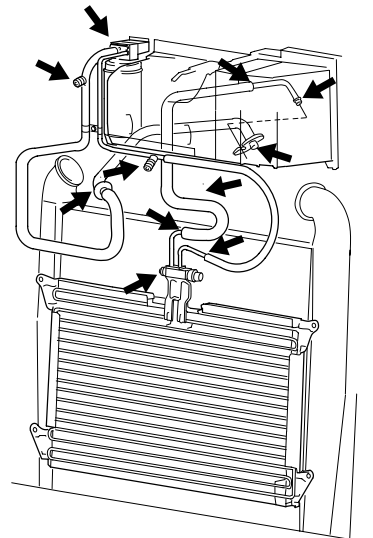
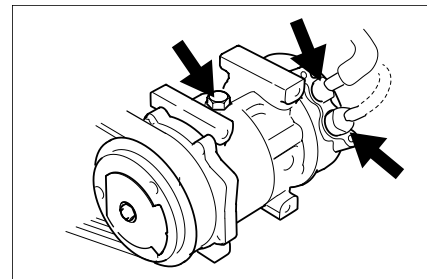

100785

*Leakage points, version 2*

# Compressor

## General

### Specifications

#### General data

Compressor oil, type	PAG oil, Part No. 584 110
Compressor oil, quantity	0.240 litres
Safety valve opening pressure	(33.8 - 41 bar)
Low-pressure monitor cut-out pressure	(1.96 bar)
High-pressure monitor cut-out pressure	(31.4 bar)

#### Tightening torque

Compressor oil plug	10 Nm
Compressor valve plate	34 Nm
Pipe to compressor	22 Nm
Pipe to condenser	8 Nm
Pipe to evaporator	8 Nm
Centre nut	30 Nm
Cylinder head, type B	32 Nm
Cylinder head, type C	34 Nm

## Renewal

### Removal

- 1 Drain the refrigerant from the AC system. Refer to "Working with refrigerant, Draining"
- 2 Unscrew the hoses from the compressor. Fit protection plugs to the compressor as well as the hose ends to prevent moisture and dirt from entering the AC system.
- 3 Detach the clutch coil electrical connector.
- 4 Undo the compressor retaining nuts, detach the drive belt and remove the compressor.

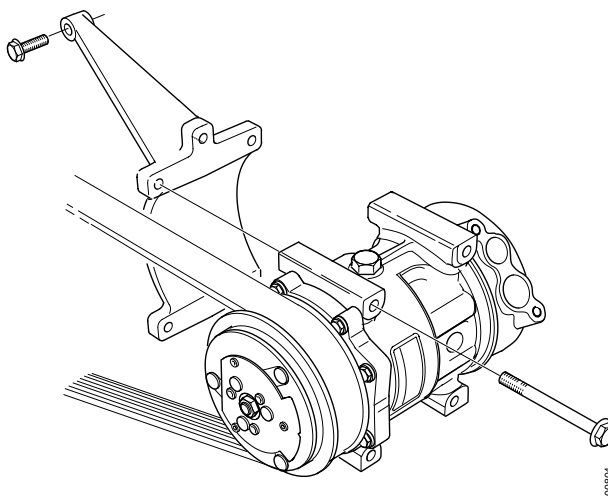

### Fitting

**Note:** If a new compressor is to be fitted, check that a hissing sound can be heard when removing the protection plugs. This confirms that the compressor is sealed and free from moisture. If no hissing sound can be heard, do not fit the compressor to the vehicle.

- 1 Position the compressor and fit the drive belt.
- 2 Fit the compressor.
- 3 Plug in the clutch coil electrical connector.
- 4 Remove the protection plugs from the compressor and the hose ends. Fit new O-rings to the hose ends and lubricate the O-rings with compressor oil.
- 5 Fit the hoses to the compressor. Tighten the bolts to 22 Nm.
- 6 Renew the dehydrator. Refer to "Dehydrator".
- 7 Vacuum pump, check for leaks and fill up the AC system. Refer to "Working with refrigerant, Refilling"

## Compressors type B and C

### Compressor type B

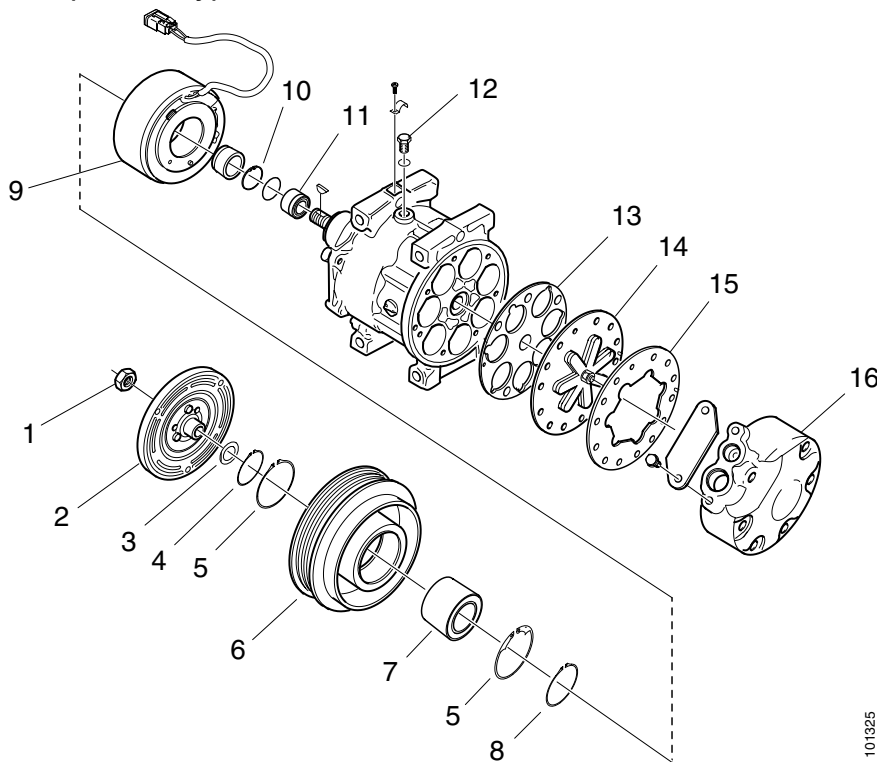

- 1 Centre nut
- 2 Rotor
- 3 Spacer
- 4 Retaining ring
- 5 Retaining ring
- 6 Pulley
- 7 Ball bearing
- 8 Retaining ring
- 9 Clutch coil
- 10 Retaining ring
- 11 Shaft seal
- 12 Plug
- 13 Gasket
- 14 Valve plate
- 15 Gasket
- 16 Cylinder head

101325

### Compressor type C

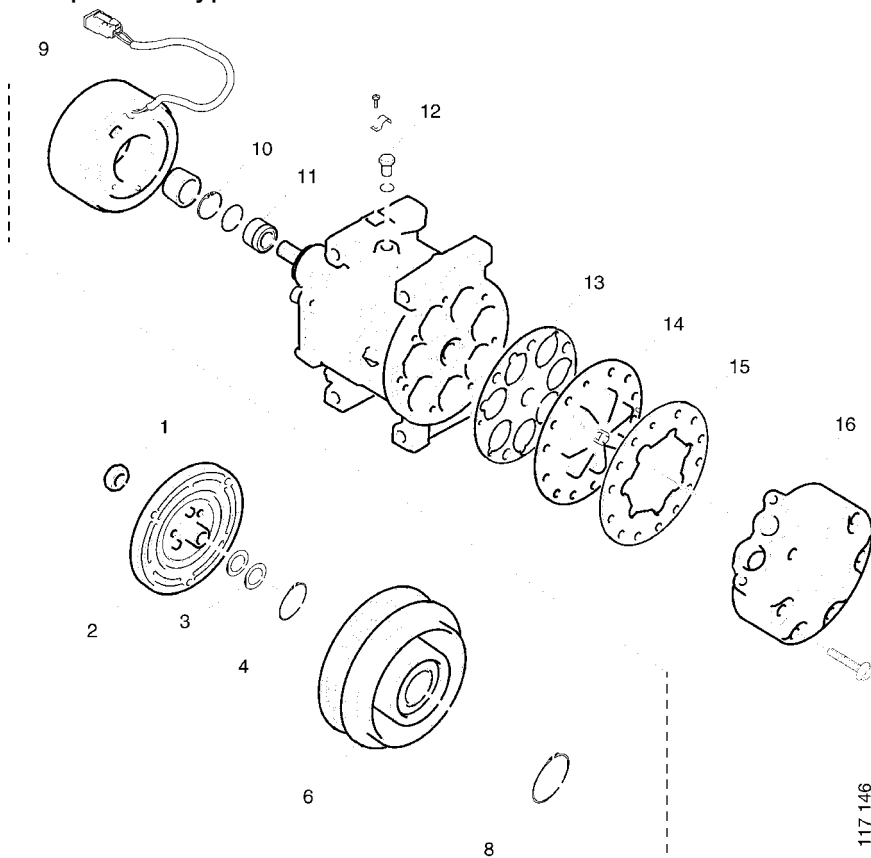



117 146

## Shaft seal

### Renewal

The item numbers in the instructions refer to the illustration on page 17.

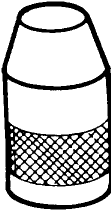
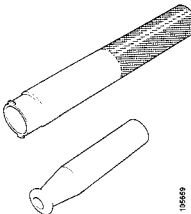
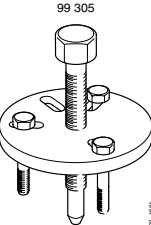
### Special tools

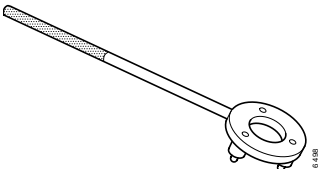
Number	Description	Illustration	Tool board
87 423	Drift	 105278	D1
99 294	Tool for shaft seal The protection sleeve is only used for compressor type B	 10669	C1
99 305	Rotor puller	 99 305	C1
99 406	Protection sleeve	 116 488	C1
99 407	Counterhold	 99 407	C1

## Removal

- 1 Remove the compressor, refer to "Compressor, Removal".

**WARNING!**

**The compressor oil plug must NEVER be removed if there is still refrigerant in the AC system. Oil and refrigerant will then blow out.**

- 2 Undo the oil plug 12 and drain the compressor oil into a measuring cylinder. Make a note of the quantity and discard the oil. The old oil has absorbed moisture and must not be reused.
- 3 Remove the centre nut 1. **Use 99 407 as counterhold on compressor type C.**
- 4 Remove the rotor 2. **Use puller 99 305 on compressor type B.**

**Note:** Threaded holes 1/4" UNC.

- 5 **Type B:** Remove the Woodruff key.
- 6 Remove the spacers 3 (if fitted).
- 7 Remove the felt ring.
- 8 Remove the retaining ring 10.
- 9 Fit tool 99 294. Press down on the tool, compressing the spring in the shaft seal 11. Turn the tool until the lugs engage. Lift up the shaft seal and the O-ring.

### Fitting

**IMPORTANT!** Never refit sealing components that have been removed from the compressor. Fit new sealing components.

- 1 Fit a new shaft seal 11 with O-ring into tool 99 294. Submerge the seal in compressor oil.
- 2 **Type B:** Fit the protection sleeve of 99 294 on to the compressor shaft.
- 3 Insert the tool into the compressor. Press down on the tool and turn until the lugs disengage.
- 4 **Type C:** Fit the protection sleeve of 99 406 on to the compressor shaft.
- 5 Remove the protection sleeve.
- 6 Fit the retaining ring 10.
- 7 Fit the felt ring. Use e.g. drift 87 423.
- 8 Refit the spacers 3.
- 9 **Type B:** Fit the Woodruff key.
- 10 Fit the rotor 2. **Using a soft mallet, tap on compressor type B.**
- 11 Using a feeler gauge, check that the distance between the pulley 6 and the rotor 2 is within 0.4 - 0.8 mm.
- 12 Fit the nut 1. **Use 99 407 as counterhold on compressor type C.**
- 13 Fill up with new oil in the same quantity as the quantity drained. The old oil has absorbed moisture and must not be reused.
- 14 Tighten the oil plug 12 to 10 Nm.
- 15 Fit the compressor. Refer to "Compressor, Fitting"

## Clutch coil and pulley

### Renewal

The item numbers in the instructions refer to the illustration on page 17.

### Special tools

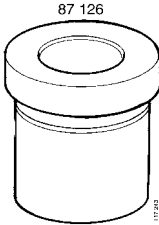
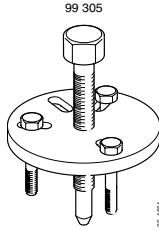
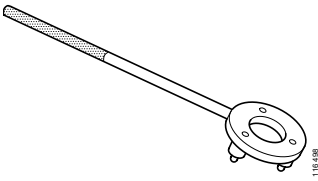
Number	Description	Illustration	Tool board
87 089	Drift		AM2
87 126	Drift		AM2
99 305	Rotor puller		C1
99 407	Counterhold		C1

### Other tools

Number	Description	Illustration	Tool board
587 511	Pulley puller	-	XA3

## Removing the clutch coil

- 1 Remove the compressor. Refer to "Compressor, Removal"
- 2 Fix the compressor in a vice, pulley up.
- 3 Remove the centre nut 1. **Use 99 407 as counterhold on compressor type C.**
- 4 Remove the rotor 2. **Use puller 99 305 on compressor type B.**

**Note:** Threaded holes 1/4" UNC.

- 5 Remove the retaining ring 4 for the pulley 6.
- 6 Fit puller 587 511 and pull off the pulley.
- 7 Detach the cable clamp.
- 8 Remove the coil retaining ring. Remove the clutch coil 9.

## Fitting the clutch coil

- 1 Fit the clutch coil 9. Make sure that the stamping at the base of the coil aligns with the marking in the compressor housing.
- 2 Fit the cable clamp.
- 3 Fit the pulley 6 and tap it down using a soft mallet.
- 4 Fit the retaining ring 4.
- 5 Fit the rotor 2. **Using a soft mallet, tap on compressor type B.**
- 6 Using a feeler gauge, check that the distance between the pulley 6 and the rotor 2 is within 0,4 - 0.8 mm.
- 7 Fit the nut 1. **Use 99 407 as counterhold on compressor type C.**
- 8 Fit the compressor. Refer to "Compressor, Fitting"

## **Compressor type B.** Removing the pulley bearing

- 1 Perform "Removing the clutch coil" through step 6.
- 2 Remove the retaining rings 5 for the bearing 7 of the pulley.
- 3 Tap out the bearing using drift 87 089.

## **Compressor type B.** Fitting the pulley bearing

- 1 Tap in a new bearing using drift 87 126.
- 2 Fit the retaining rings 5 securing the bearing to the pulley.
- 3 Perform "Fitting the clutch coil" from step 3 onwards.

## Cylinder head / valve plate

### Renewal

The item numbers in the instructions refer to the illustration on page 17.

### Removal

- 1 Remove the compressor, refer to "Compressor, Removal".



**WARNING!**

**The compressor oil plug must NEVER be removed if there is still refrigerant in the AC system. Oil and refrigerant will then blow out.**

- 2 Undo the oil plug 12 and drain the compressor oil into a measuring cylinder. Make a note of the quantity and discard the oil. The old oil must not be reused.
- 3 Fix the compressor in a vice, cylinder head 16 up. Mark the cylinder head position in relation to the compressor housing.
- 4 Remove the cylinder head 16 and the gasket 15.
- 5 Detach the valve plate 14 and its gasket 13.

**Note:** Do not scratch the mating surfaces. Remove gasket residues from the components.

### Fitting

- 1 Position a new gasket 13 and valve plate 14 on the compressor housing. Align the guide pin with the valve plate guide hole. Otherwise the retaining bolts will not fit.
- 2 Position a new gasket 15 and cylinder head 16 so that the marks align.
- 3 **Type B:** Insert the bolts and tighten them crosswise to 32 Nm.
- 4 **Type C:** Insert the bolts and tighten them to 20 Nm. Then, tighten them to 34 Nm in

the sequence shown.

- 5 Fill up with new oil in the same quantity as the quantity drained. The old oil has absorbed moisture and must not be reused.
- 6 Tighten the oil plug 12 to 10 Nm.
- 7 Fit the compressor. Refer to "Compressor, Fitting"

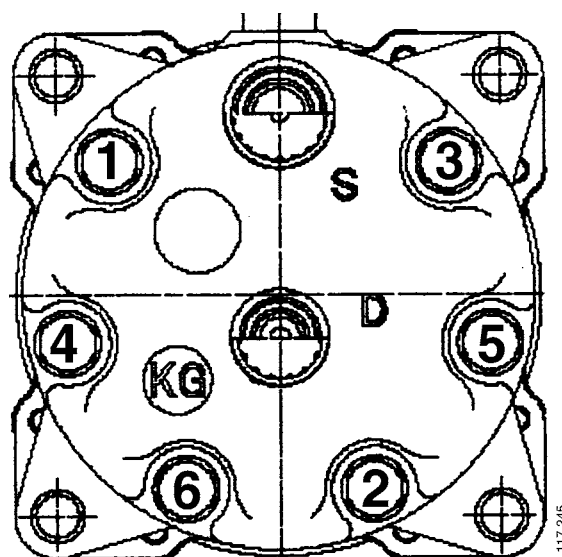

*Compressor type C: Tightening sequence for cylinder head bolts*

## Condenser

### Renewal

#### Removal

- 1 Drain the refrigerant. Refer to "Working with refrigerant, Draining"
- 2 Remove the centre front grille.
- 3 Detach the hoses and fit protection plugs to the hoses and the condenser connections.
- 4 Remove the condenser retaining bolts.
- 5 Lift off the condenser.

#### Fitting

- 1 Fit the condenser, connection up.
- 2 Tighten the retaining bolts.
- 3 Remove the protection plugs and fit the hoses.
- 4 Renew the dehydrator. Refer to "Dehydrator".
- 5 Fill up with refrigerant. Refer to "Working with refrigerant, Refilling"
- 6 Fit the centre front grille.

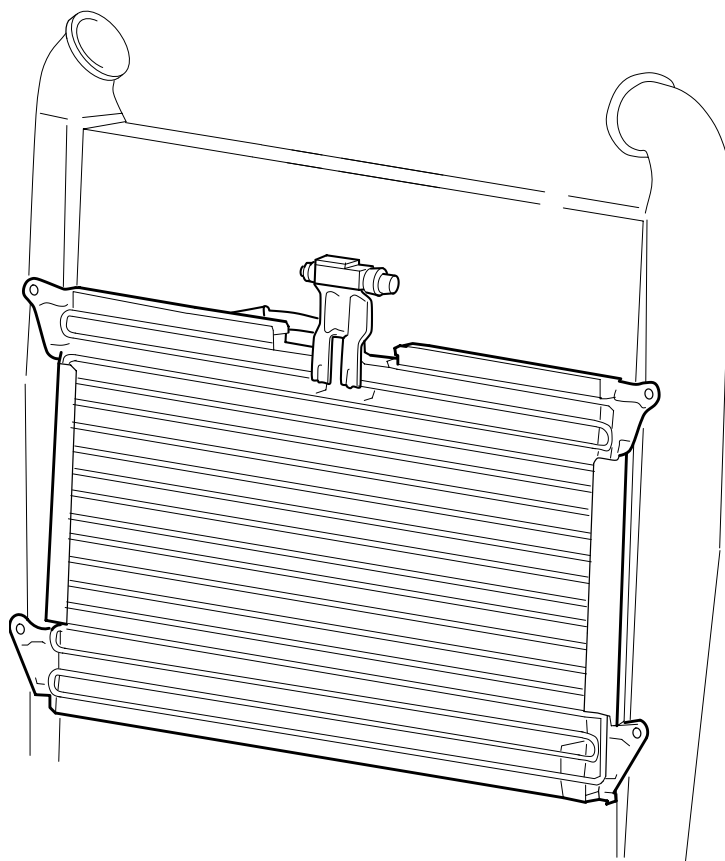

100316

# Hoses

## Removal and fitting

### Other tools

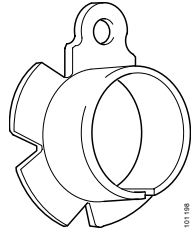
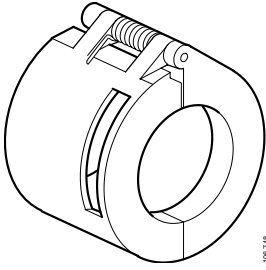
Number	Description	Illustration	Tool board
588 118	Hose tool, old version		C1
588 118	Hose tool, new version		C1

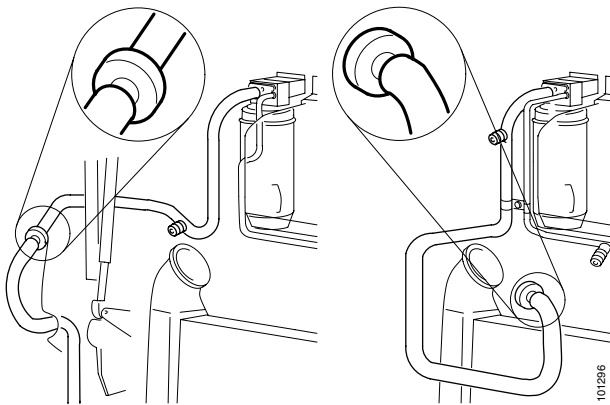

*SUC hose coupling, versions 1 and 2*

## Removal

- 1 Drain the refrigerant. Refer to "Working with refrigerant, Draining"
- 2 Remove the clamp 1.
- 3 Fit tool 588 118 on to the hose.
- 4 Compress the coupling, at the same time pulling the tool rearwards to release the spring retaining the hoses.
- 5 Disconnect the coupling and plug the hose ends.

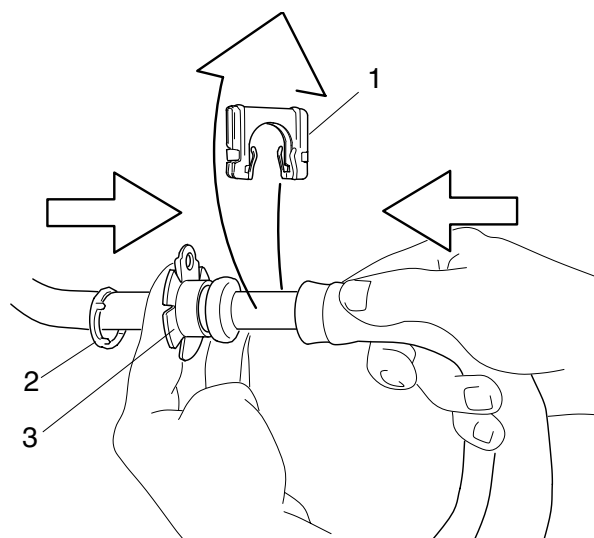

- 1 *Clamp*
- 2 *Plastic ring*
- 3 *Tool 588 118*

101194

## Fitting

- 1 Connect the coupling by pressing the hose ends together.  
  
When connecting the coupling, push the white plastic ring 2 out from the coupling. This indicates that the coupling has engaged.
- 2 Fit the clamp 1 on to the coupling flange.
- 3 Renew the dehydrator. Refer to "Dehydrator".
- 4 Fill up with refrigerant. Refer to "Working with refrigerant, Refilling"

# Control motor

## Removal

- 1 Remove the outer air duct 1.

**Note:** If fitted, coarse filter 1 should be replaced with ventilation grille 4 on P and R cabs.

- 2 Remove the recirculation damper 2.
- 3 Detach the connectors for the limit switches.
- 4 Remove the bracket 3 and the link 4.
- 5 Detach the electrical connector and the control motor 5 from the bracket 3.

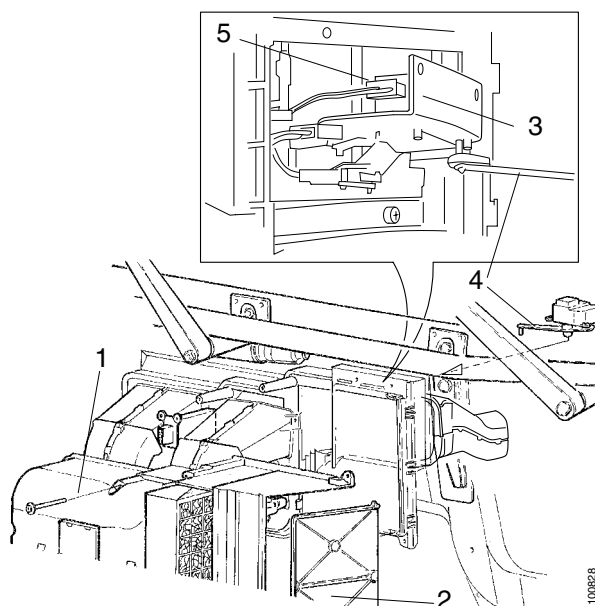

## Fitting

- 1 Fit the control motor 5 to the bracket 3. Fit the link 4 and plug in the electrical connector.
- 2 Fit the control motor bracket 3 to the heater housing.
- 3 Plug in the connectors for the limit switches.
- 4 Fit the recirculation damper 2.
- 5 Fit the outer air duct 1.

**Note:** Make sure the cab air filter faces the correct way.

# Thermostat

## Removal

- 1 Remove the fan motor and the fan cowling 4. Refer to "Fan motor".
- 2 Remove the plate 5 and the screws (6 pcs) retaining the heater housing to the recirculation duct.
- 3 Remove the clip for the capillary tube from the base of the evaporator. Work through the air passage (arrow).
- 4 Remove the thermostat 6. Ease out the heater housing and extract the capillary tube from the fan duct through the gap in the recirculation duct.

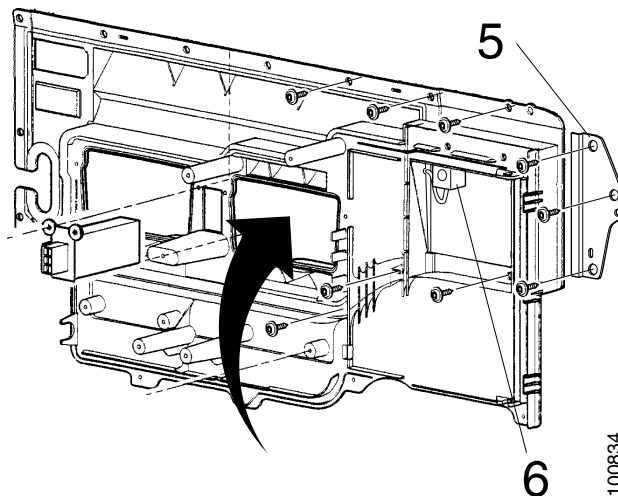

## Fitting

- 1 Pass the capillary tube from the recirculation duct to the evaporator.

**Note:** Be careful. The capillary tube is very sensitive to bending! It must not be kinked.

- 2 Fit the thermostat 6.
- 3 Fit the capillary tube with the clip to the base of the evaporator (location shown).
- 4 Fit the heater housing and the plate 5. Make sure that the capillary tube is not crushed when bolting down the heater housing!
- 5 Fit the fan cowling 4 and the fan motor. Refer to "Fan motor".

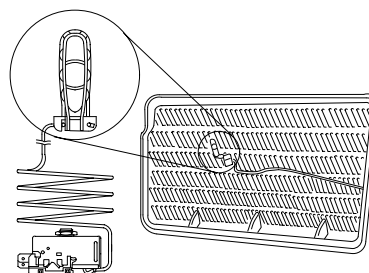

*Capillary tube on base of evaporator as viewed through the air passage*

# Water valve

## Removal

- 1 Drain the coolant, at least down to the pipe branch. Refer to Workshop manual group 2, Cooling system.

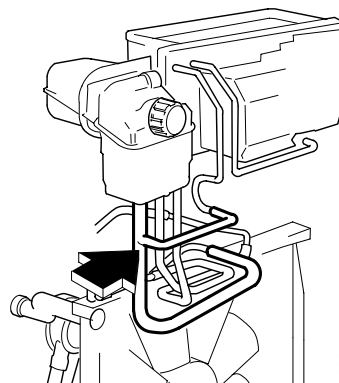

100819

- 2 Detach the coolant pipes 1 at bracket 2.
- 3 Remove the bolts that secure the pipes to the water valve 3 and the bracket 4.
- 4 Remove the coolant pipes.
- 5 Remove the two water valve retaining bolts.
- 6 **AC with ETC:** Disconnect the electrical connector.

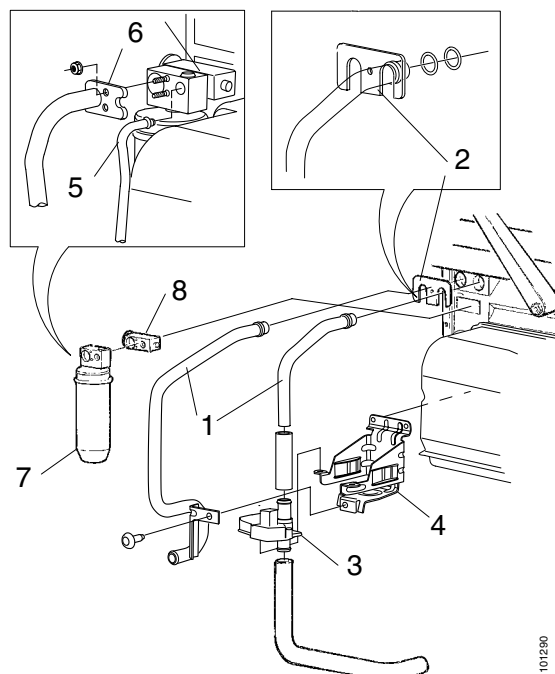

101280

- 7 **AC without ETC:** Detach the cable and the clamp from the water valve 3.

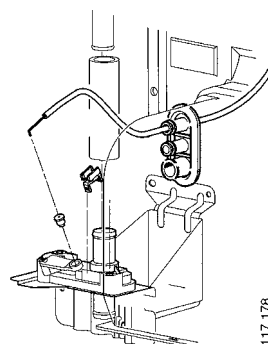

117 178

*Cable and clamp*

## Fitting

- 1 Fit the water valve 3 in the bracket 4.
- 2 **AC with ETC:** Plug in the valve electrical connector.
- 3 **AC without ETC:** Set the temperature control in the cab to "0". Close the water valve by turning the lever fully anti-clockwise. Fit the cable and the clamp to the water valve 3.
- 4 Fit the coolant pipes 1 to the valve 3.

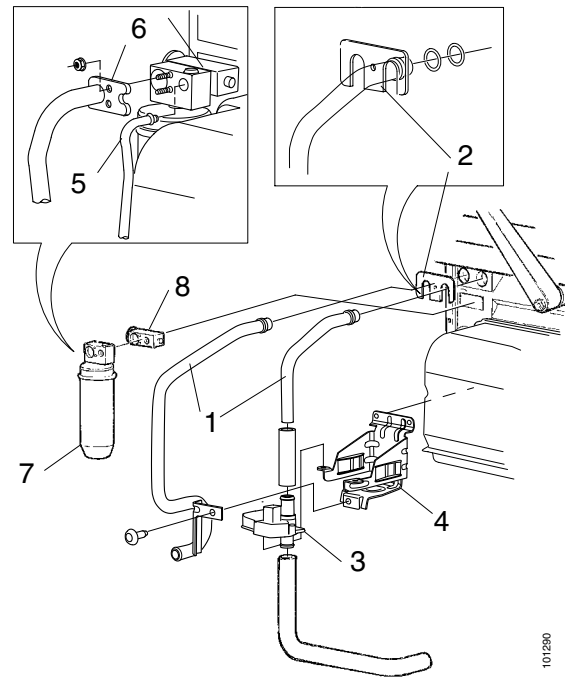

- 5 Fit new O-rings to the coolant pipes and grease them with petroleum jelly. Two O-rings per pipe at the same side of the flanges.
- 6 Secure the coolant pipes with the holder 2, tightening torque 8 Nm.
- 7 Bolt the coolant pipe 1 to the bracket 4.
- 8 Fill with coolant. Refer to "Cooling system" group 2.
- 9 Run the engine until it reaches operating temperature.
- 10 Check that the temperature control functions and check hoses and pipe couplings for leakage.
- 11 **AC with ETC:** Keep the diagnostics switch depressed and switch on the ignition. This will clear any fault codes and make the control unit test how much it can move the valve.

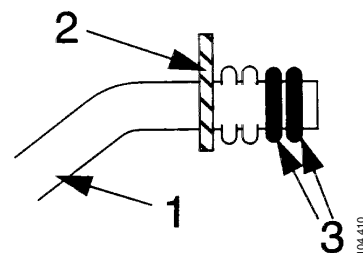

- 1 *Coolant pipe*
- 2 *Bracket*
- 3 *O rings*

## Dehydrator / Expansion valve

### Removal

- 1 Drain the refrigerant. Refer to "Working with refrigerant".
- 2 Remove the water valve, refer to section "Water valve".
- 3 Evacuate the system again. There may be some residual pressure in the dehydrator.
- 4 Detach and plug the AC pipes 5 and 6 at the dehydrator.
- 5 Remove the dehydrator 7 or the expansion valve 8 and the dehydrator.

### Fitting

- 1 Fit a new dehydrator. Fit a new expansion valve (if equipped). Renew the O-rings between dehydrator, expansion valve and evaporator and grease them with PAG oil.
- 2 Renew the O-rings of the AC pipes and grease the with PAG oil.
- 3 Fit the AC pipes to the dehydrator, tightening torque 8 Nm. Grease the studs with PAG oil.
- 4 Fit the water valve, refer to section "Water valve".
- 5 Vacuum pump, check for leaks and fill up the AC system. Refer to "Working with refrigerant".

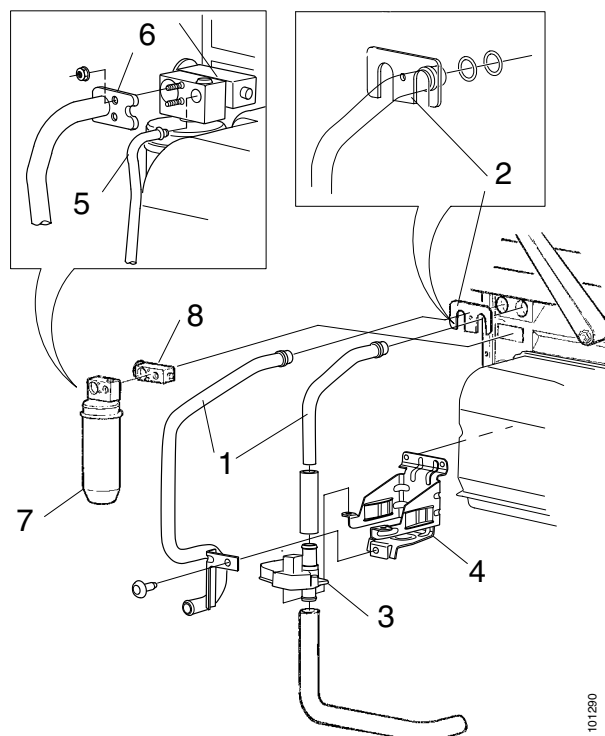

101280

# Evaporator / Heat exchanger

## Removal

- 1 **AC:** Drain the AC system. Refer to "Working with refrigerant".
- 2 Drain the coolant. Refer to "Cooling system" group 2.
- 3 Remove the upper front grille panel.
- 4 Remove the ventilation grille 4 or the coarse filter 1.

**Note:** If fitted, coarse filter 1 should be replaced with ventilation grille 4 on P and R cabs.

- 5 Remove the cab air filter 2.

**Note:** Note how the cab air filter is fitted. It must be refitted in the same way.

- 6 Remove the outer air duct 3.
- 7 Disconnect the electric cable for the wipers and detach the washer hoses from the reservoir at the T branching and detach them from the clips, 2 pcs.
- 8 Remove the bracket for the windscreen wipers and the front grille panel.
- 9 **AC:** Remove the recirculation damper 14 and detach the control motor 17 (refer to "Control motor" step 4). Let the motor remain in the recirculation duct.

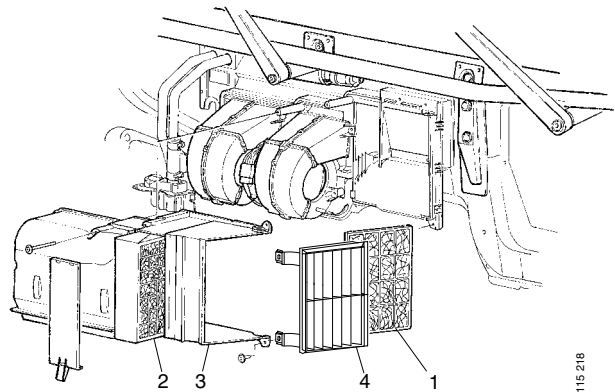

115 218

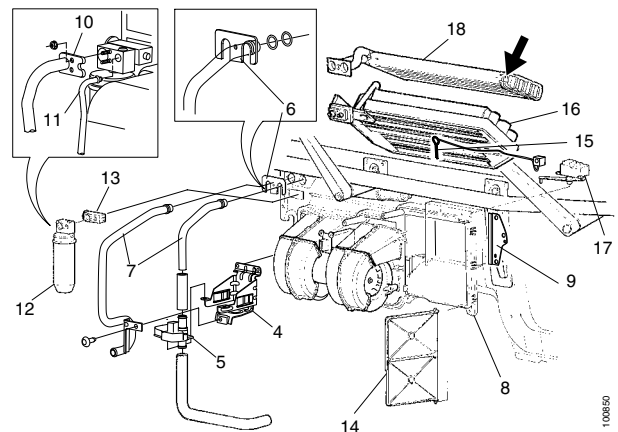

100850

- 10 Disconnect and detach the wiring to the fan resistor unit and the fan motor.
- 11 Detach the coolant pipes 7 at the bracket 6.
- 12 Remove the bolts that secure the pipes to the water valve 5 and the bracket 4.
- 13 Remove the coolant pipes 7.
- 14 **AC with ETC:** Disconnect the electrical connector from the water valve 5. Ensure that coolant does not enter the connector.
- 15 **AC without ETC:** Detach the cable and the clamp from the water valve.
- 16 Detach the water valve from the bracket 4.
- 17 **AC:** Detach the AC pipe with the bracket 10 at the dehydrator and plug the pipe.
- 18 **AC:** Detach the AC pipe 11 and plug the pipe.
- 19 **AC:** Remove the dehydrator 12.
- 20 **AC:** Remove the expansion valve 13 and plug the evaporator and expansion valve openings.
- 21 Remove the heat exchanger cover 8 and the plate 9.
- 22 **AC:** Detach the clip for the capillary tube 15 from the base of the evaporator.
- 23 **AC:** Remove the evaporator 16.
- 24 Unscrew the bolt securing the heat exchanger to the heater housing (arrow at item 18).
- 25 Remove the heat exchanger 18.

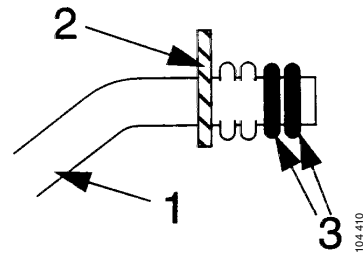
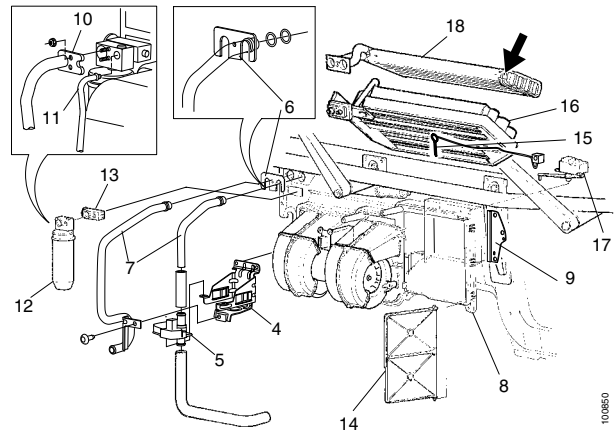

**Note:** Be careful, there may still be coolant inside the heat exchanger.

## Modification of heat exchanger and damper housing

The temperature of the warm air entering the cab may on earlier trucks be too low when the ambient temperature is low. One cause is that too much fresh air is mixed with the heated air in the heater unit.

The following measures raise the temperature of the incoming warm air. The measures are introduced in production from September 1998 and the following chassis numbers:

Scania Södertälje	1 242 946
Scania Zwolle	4 398 440
Scania Angers	9 035 140

### List of measures

- 1 Change to a more effective heat exchanger with improved sealing against the damper housing.
- 2 Fit an extra seal plate 1 to prevent unheated air from leaking into the cab. This permits use of the air distribution control between the positions panel air vents and floor air vents, without the addition of fresh air. In this way, the temperature of the air from the panel air vents is raised. The damper housing must be adapted to the new seal plate.

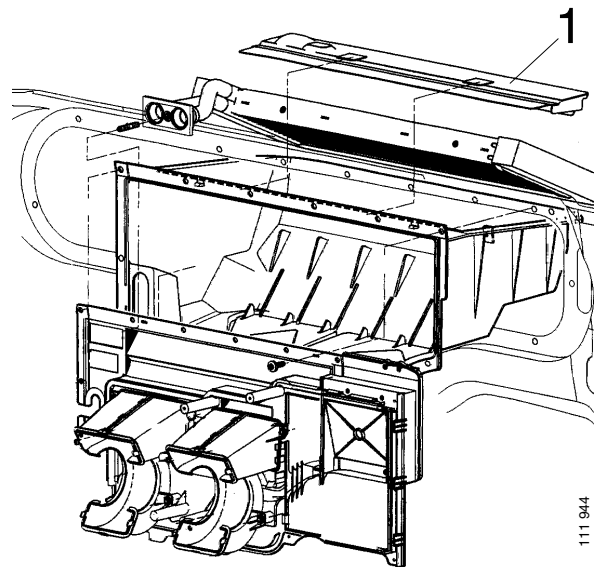

- 3 The air resistance is greater in the new heat exchanger. Increase the fan speed in the fan switch positions 1 and 2 in order to maintain the same air flow as before, by changing the fan resistor unit R2 from 1.5 ohms to 0.9 ohms.

- 4 The sealing of the recirculation damper is improved by the introduction of a new bracket for the control motor. This reduces the risk of cold air leaking into the cab. On previously modified trucks, secure the cold air damper with screws 1 as shown.

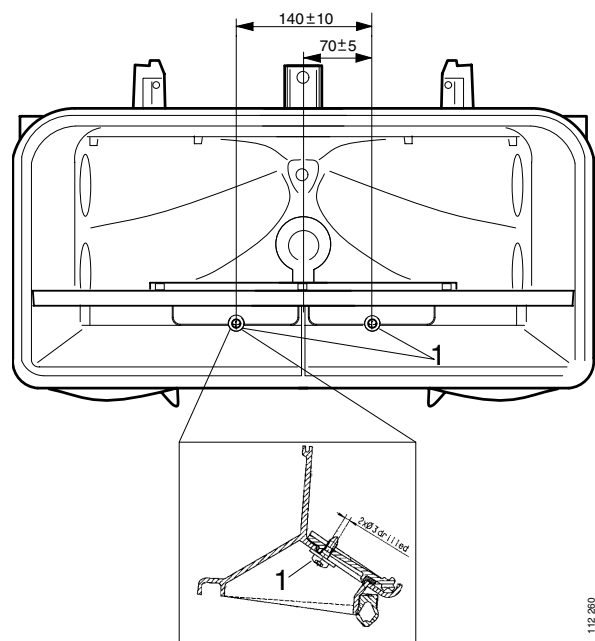

## Description

- 1 Remove the rubber moulding 1.

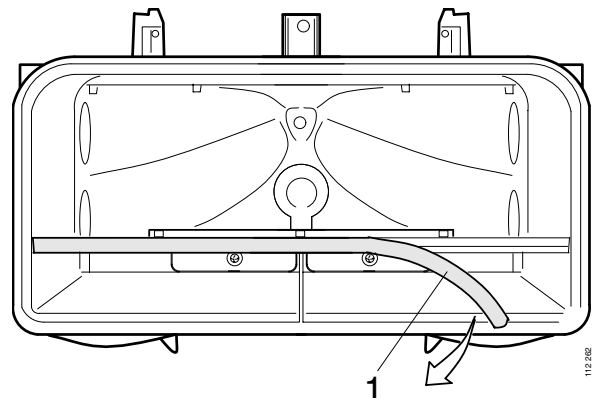

- 2 Modify the damper housing. Make a recess for the seal plate as shown.

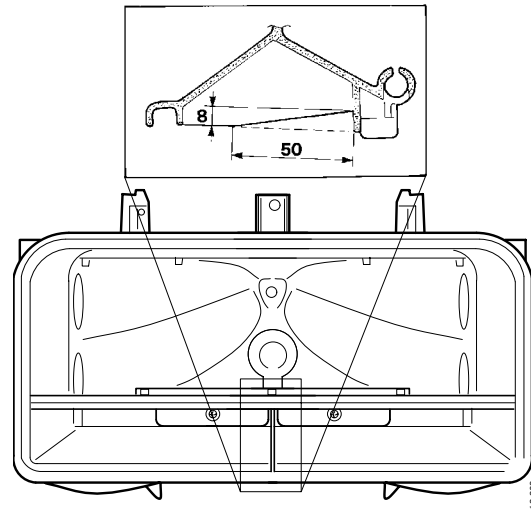

- 3 Make a new recess for the pipe at 2. The recess should have the same shape as the existing recess at 1.
- 4 Check that the seal strip 3 between the upper and lower damper housings is correctly seated.

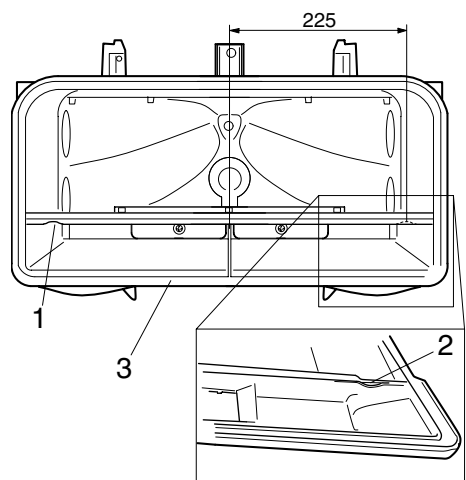

- 5 Fit the new heat exchanger and seal plate. Clamp the seal plate in position, between the heat exchanger and the damper housing. Snap the plate in place as shown.

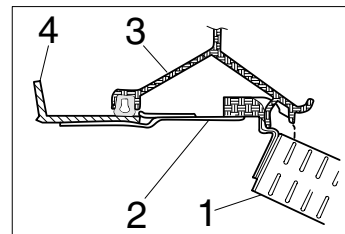
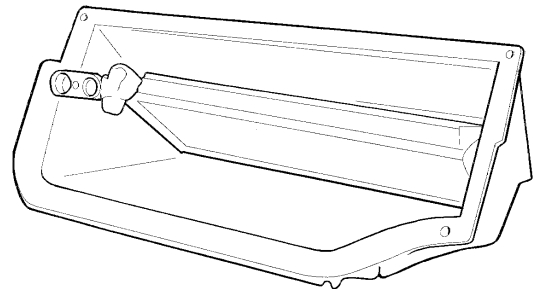

- 6 Renew the fan resistor unit, refer to "Fan resistor unit, Renewal".

- 1 Heat exchanger
- 2 Seal plate
- 3 Damper housing
- 4 Heater housing

## Insulation of member below defroster duct

The temperature of the warm air entering the cab may on earlier trucks be too low when the ambient temperature is low. This is partly due to the heated air in the heater assembly being cooled by the ram air.

The member below the defroster duct is now insulated in production from chassis numbers:

Scania Södertälje	1 242 946
Scania Zwolle	4 398 440
Scania Angers	9 035 140

For modification of earlier vehicles, a self-adhesive insulation is available, which should be fitted when the modification of the heat exchanger unit is carried out.

### Description

- 1 Remove the upper front grille panel and brackets.
- 2 Remove the windscreen wiper wiring.
- 3 Detach the washer hoses and remove the windscreen wipers.
- 4 Remove dirt and grease from the defroster member.
- 5 Remove the protective foil from the insulation and fit the insulation.
- 6 Fit the windscreen wipers and the washer hoses.
- 7 Refit the windscreen wiper wiring.
- 8 Fit the upper front grille panel and brackets.

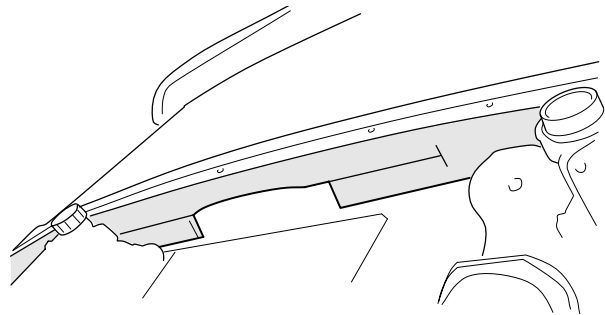

## Recirculation of cab air

Vehicles with tree-position AC switch can be modified to include separate control for recirculation of cab air. The recirculation can be used to prevent contaminated air from entering the cab. It may also be used for quicker heating.

### Description

- 1 Modify the wiring according to the wiring diagram and the Workshop manual 18:03-40.
- 2 Remove the tree-position AC switch and fit a two-position switch instead.
- 3 Fit the second two-position switch to the panel section to the right of the heater controls. Use a vacant location close to the fan switch.

### New electrical parts

Description	Discontinued parts	New parts
Cable harness		1 420 861
Switch	1 353 076	1 421 036
Switch		353 621

## Wiring diagram for modification of recirculation of cab air

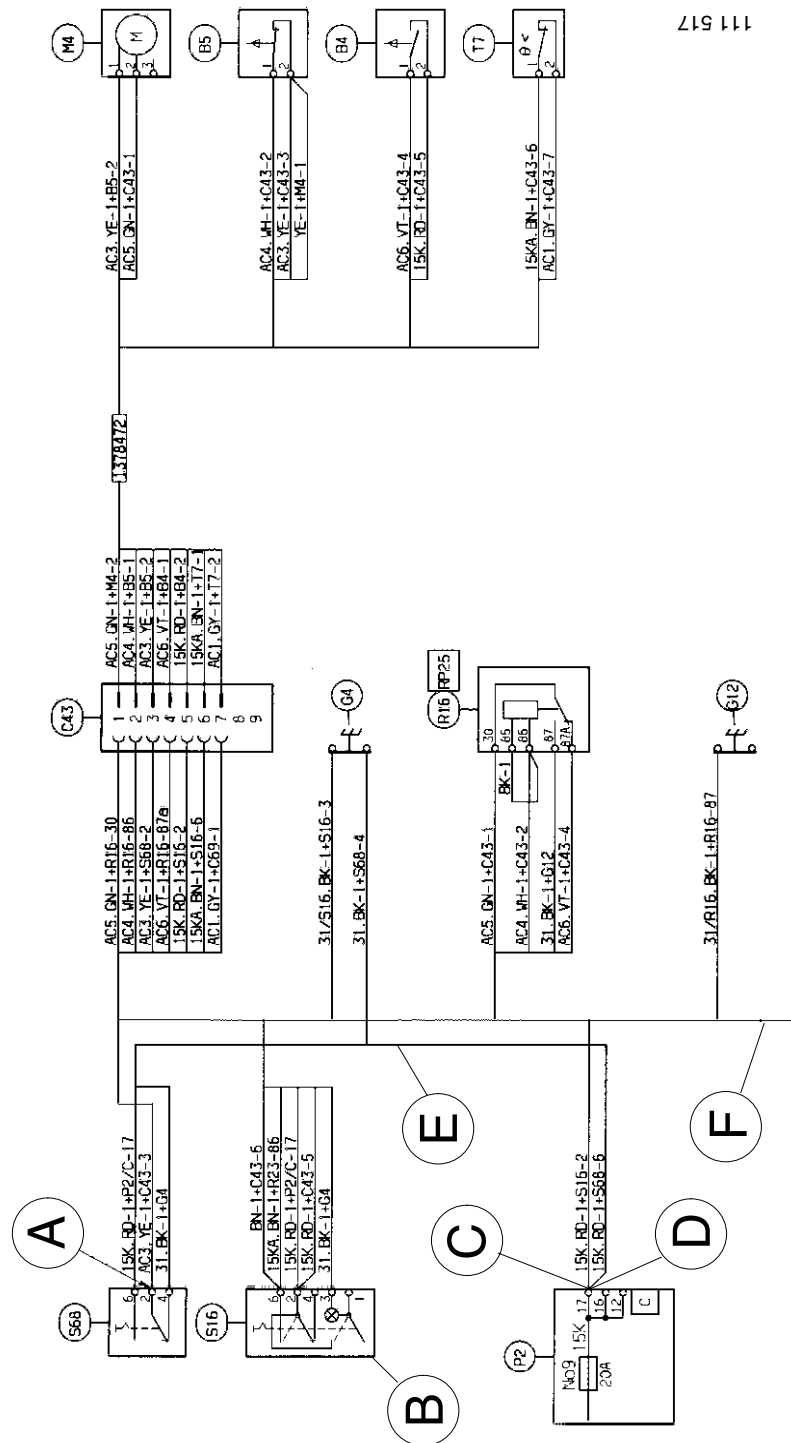

111 517

A. Lead shifted from S16-2

B. New two-pin switch replaces three-pin switch. Change the lead connections in the connector according to the diagram for the new switch.

C. Connect the lead from S16 to the lead from S68.

D. Fit flat pins to the leads and connect them to P2/C-17.

E. New cable harness 1 420 861

F. Existing cable harness for ETC and AC



- 12 Fit new O-rings to the coolant pipes 7 and grease them with petroleum jelly. Two O-rings per pipe at the same side of the flanges.

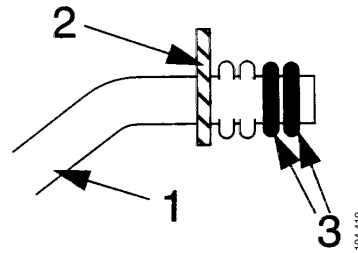

- 1 Coolant pipe  
2 Bracket  
3 O rings

- 13 Connect the coolant pipes 5 to the valve.
- 14 Fit the coolant pipe with bracket 6.  
Tightening torque 8 Nm.
- 15 Fit the coolant pipes 7 to the bracket 4.
- 16 **AC:** Fit the control motor 17. Fit the recirculation damper 14.
- 17 Connect the wiring to the fan resistor unit and the fan motor. Secure the wiring using the hooks on the heat exchanger cover.
- 18 Fit the wiper system and front grille panel bracket.
- 19 Connect the washer hoses to the windscreen wipers and connect the electrical connector.

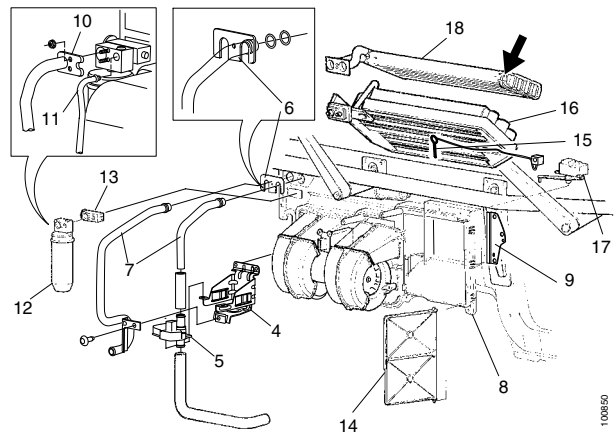

- 20 Fit the outer air duct 3. Note in which direction the cab air filter shall be fitted.
- 21 Fit the ventilation grille 4 or the coarse filter 1.

**Note:** If fitted, coarse filter 1 should be replaced with ventilation grille 4 on P and R cabs.

- 22 Fit the cab air filter 2.

**Note:** Ensure the cab air filter faces the correct way.

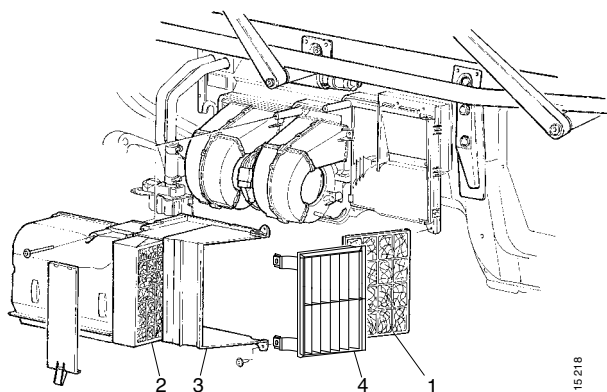

- 23 Refit the front grille panel.
- 24 Fill with coolant. Refer to "Cooling system" group 2.
- 25 Vehicle with AC: Vacuum pump, check for leaks and fill up the AC system. Refer to "Working with refrigerant".
- 26 Run the engine until it reaches operating temperature.
- 27 Check the temperature control.
- 28 **AC with ETC:** Clear any fault codes, refer to the Workshop manual group 18, ETC, fault code list. Also check hoses and pipe couplings for leakage.

# Temperature sensor

## Renewal

- 1 Detach the two centre sections of the instrument panel.
- 2 The temperature sensor is located inside the damper housing. Refer to illustration "Temperature sensor, location".
- 3 Disconnect the sensor electrical connector.
- 4 Turn the temperature sensor a quarter of a turn clockwise and extract it.
- 5 Position the new temperature sensor and turn it a quarter of a turn anti-clockwise.
- 6 Check the temperature control. Refer to ETC booklet group 18. Clear any fault codes.

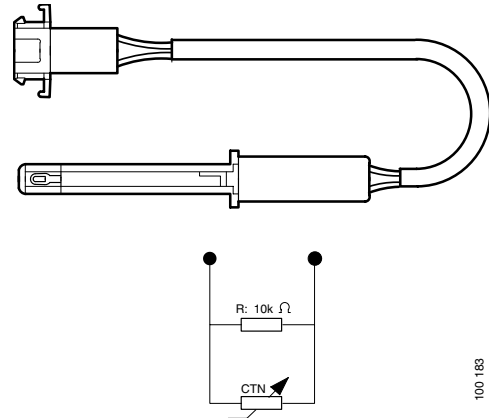

100 183

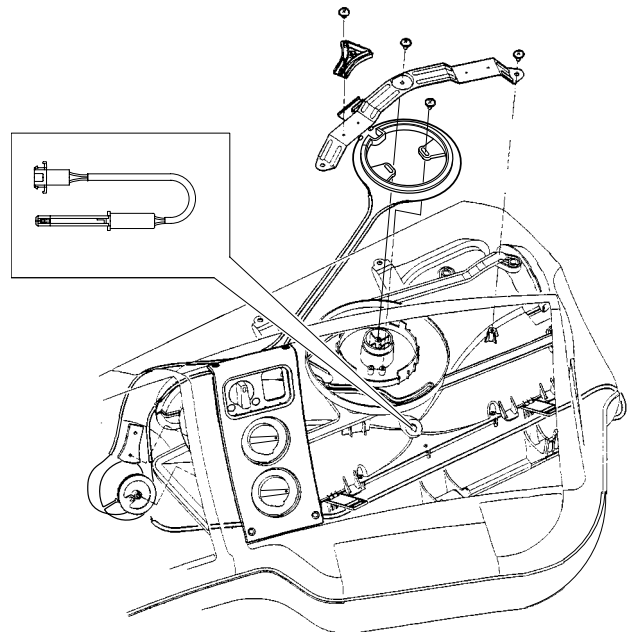

101839

# Potentiometer

## Renewal

The potentiometer is located on the temperature control.

- 1 Detach the temperature control panel.
- 2 Carefully fold out the panel.
- 3 Detach the potentiometer electrical connector.
- 4 Remove the three bolts securing the potentiometer plastic cover to the temperature control panel.
- 5 Using a screwdriver, gently pry loose the shaft coupling. The potentiometer housing shall be detached from the control panel.
- 6 Undo the nut at the potentiometer shaft.
- 7 Remove the potentiometer by pulling the plastic cover straight out.
- 8 Refit the parts in the reverse order. Ensure that the potentiometer aligns correctly with the control panel.
- 9 Check the temperature control. Refer to ETC booklet group 18. Clear any fault codes.

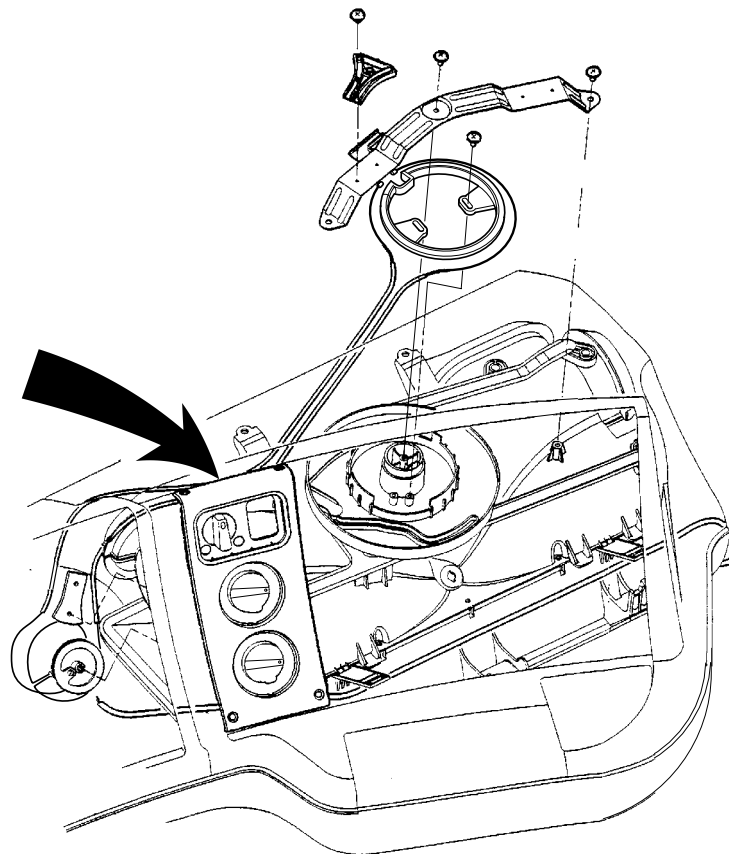

101340

# Control unit

## Replacement

The control unit is located on top of the plate below the central electric unit. It is fitted in a guide and has a snap lock at the electrical connection.

- 1 Disconnect the control unit electrical connector.
- 2 Remove the control unit and fit a new one.
- 3 While keeping the ETC diagnostics switch depressed, switch on the ignition.
- 4 Check the temperature control. Refer to ETC booklet group 18.

# Fan motor

## Removal

- 1 Remove the ventilation grille 4 or the coarse filter 1.

**Note:** If fitted, coarse filter 1 should be replaced with ventilation grille 4 on P and R cabs.

- 2 Remove the cab air filter 2.

**Note:** Note how the cab air filter is fitted. It must be refitted in the same way.

- 3 Remove the outer air duct 3.

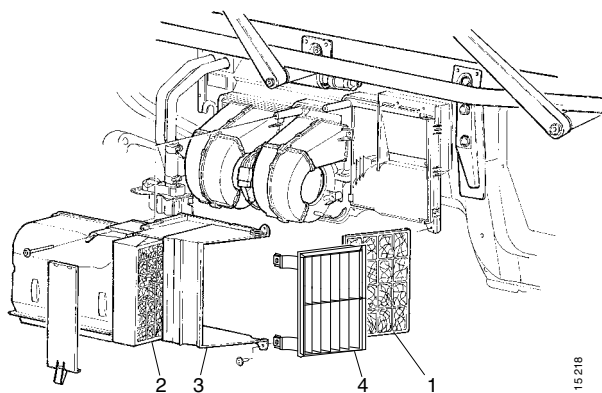

115 216

- 4 Remove the fan cowlings 1 by opening the snap locks.

- 5 Disconnect the electrical connector and the fan resistor electrical connector. Remove the motor bracket 2.

- 6 Remove the complete motor unit 3.

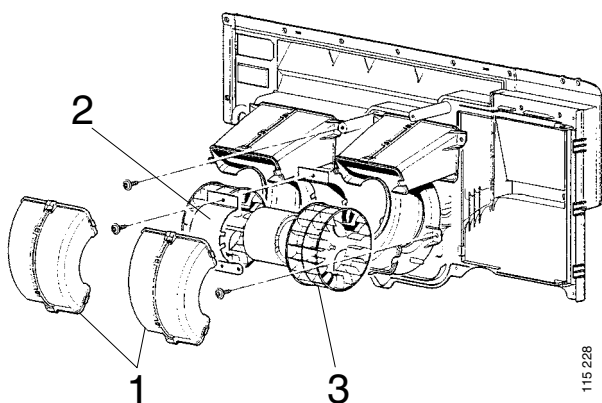

115 228

## Fitting

- 1 Fit the motor unit 3.
- 2 Fit the motor bracket 2 and the electrical connectors.
- 3 Fit the fan cowlings 1 using the snap locks.
- 4 Check that the fan rotates freely, without striking the cowlings.

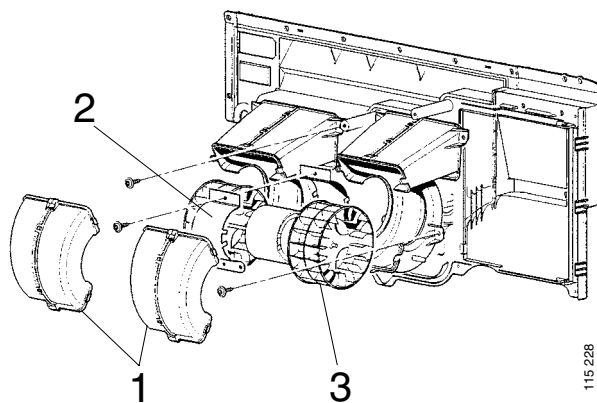

115 228

- 5 Fit the outer air duct 3.
- 6 Fit the ventilation grille 4 or the coarse filter 1. If fitted, coarse filter 1 should be replaced with ventilation grille 4 on P and R cabs.
- 7 Fit the cab air filter 2.

**Note:** Ensure the cab air filter faces the correct way.

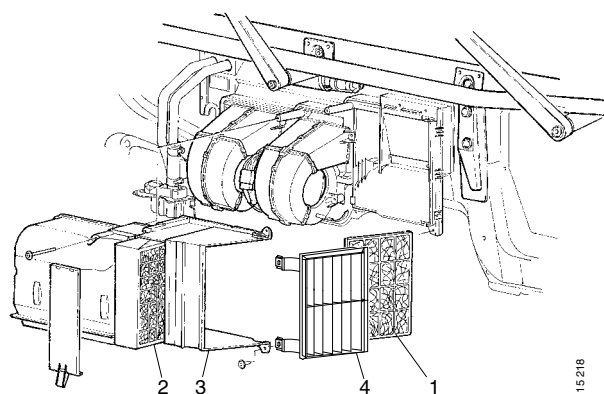

115 218

## Fan resistor unit

### Renewal

- 1 Remove the ventilation grille 4 or the coarse filter 1.

**Note:** If fitted, coarse filter 1 should be replaced with ventilation grille 4 on P and R cabs.

- 2 Remove the cab air filter 2.

**Note:** Note how the cab air filter is fitted. It must be refitted in the same way.

- 3 Remove the outer air duct 3.

- 4 Detach the electrical connector and undo the bolts of the fan resistor unit 5 between the air ducts.

- 5 Fit the fan resistor unit 5.

- 6 Fit the outer air duct 3.

- 7 Fit the ventilation grille 4 or the coarse filter 1.

**Note:** If fitted, coarse filter 1 should be replaced with ventilation grille 4 on P and R cabs.

- 8 Fit the cab air filter 2.

**Note:** Ensure the cab air filter faces the correct way.

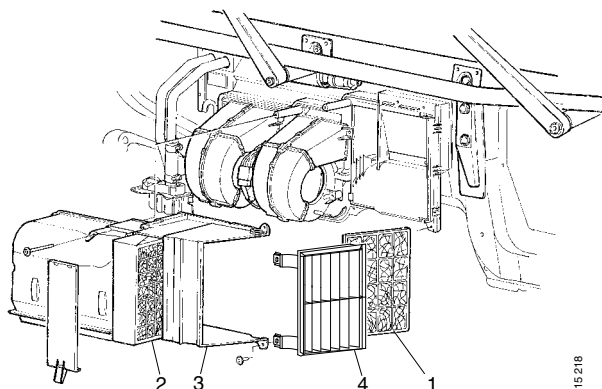

115 218

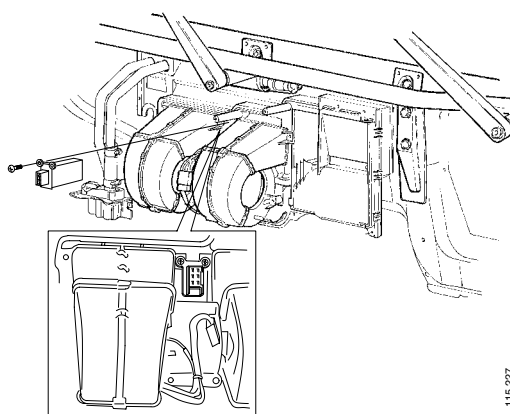

115 227

# Ventilation control cable

## Removal

- 1 Detach the panel for temperature and ventilation control on the instrument panel.
- 2 Detach the other sections in the instrument panel centre section.
- 3 Detach the cables 1 and 2 from the cable wheel 3 on the damper housing.
- 4 Detach the cables 1 and 2 from the cable wheel 4 on the control panel.
- 5 Remove the cables.

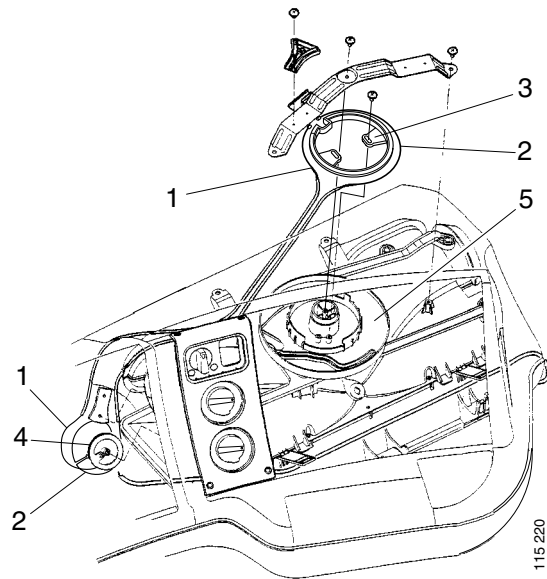

## Lubrication

Lubricate the cam disc, the axle, groove and any other plastic parts of the cam disc if required, using grease 584 084.

**Note:** Use of any other grease may cause irreparable damage to the plastic components.

## Fitting

- 1 Set the ventilation control on the panel to "0".
- 2 Close all dampers by rotating the cam disc 5 on the damper housing anti-clockwise to stop.
- 3 Fit the common attachment point for the cables to the cable wheel 4 on the control panel. Wind the cable 1 (red or blue) one revolution clockwise and cable 2 (black) a half revolution anti-clockwise.
- 4 Fit the cable wheel to the axle of the ventilation control on the panel.
- 5 Press the cable casings into the retainer on the control panel and bolt in place.
- 6 Hook the wires onto the cable wheel 3 on the damper housing.
- 7 Press the cable casings into the retainers on the damper housing and bolt into place. The black cable should be to the right.

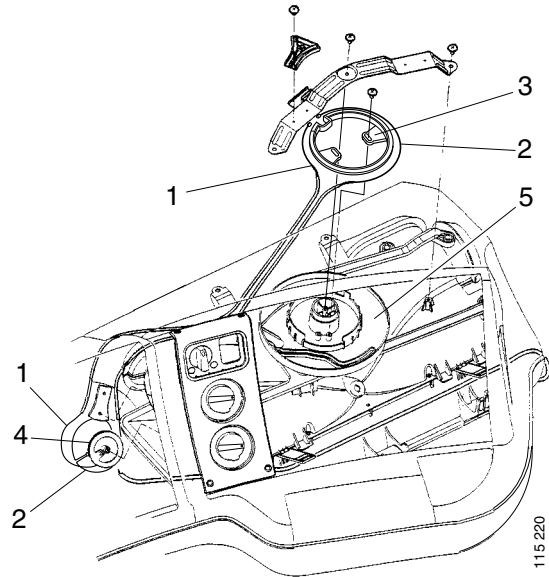

**Note:** Ensure that the cables are not twisted behind the ventilation control panel.

# Temperature control cable

## Renewal

- 1 Remove the sections on and below the instrument panel as shown for left-hand- and right-hand drive vehicles. In addition, fold up the central electric unit on left-hand drive vehicles.

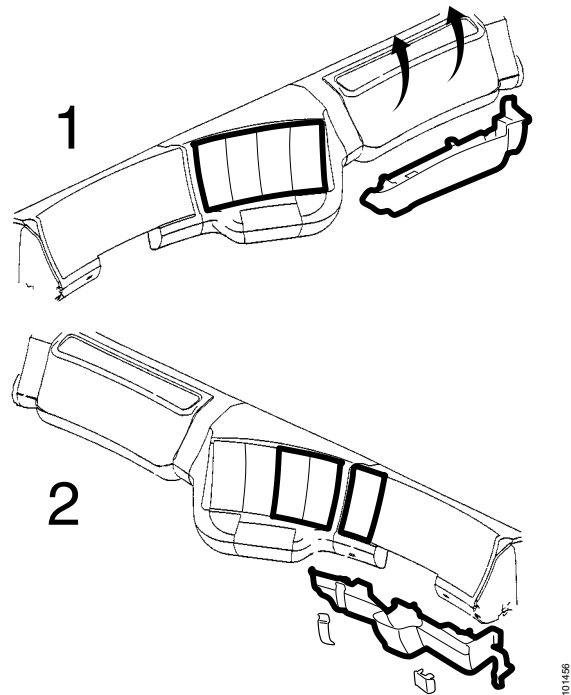

- 1 Panels to remove on left-hand drive vehicles.*  
*2 Panels to remove on right-hand drive vehicles.*

- 2 Detach the cable from the temperature control at 1.
- 3 detach the cable from the water valve at 2.
- 4 Set the temperature control 3 in the cab to "0". Close the water valve by turning the lever fully anti-clockwise.
- 5 Renew the cable. Clamp the new cable using a strap at 1. The cable should otherwise be loose without being clamped.

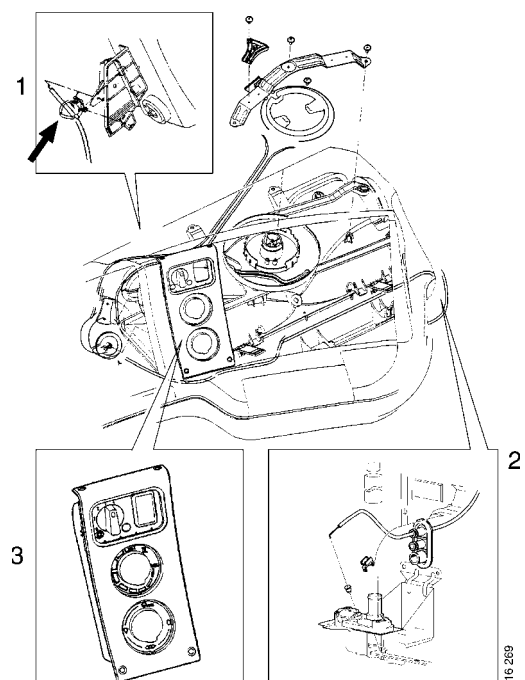

# Troubleshooting

## Equipment

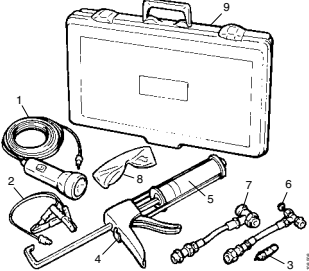
Number	Description	Illustration	Tool board
588 184	Leak detector for AC system		-

## General

Troubleshooting the temperature control is facilitated by means of flashing codes (refer to "ETC fault code list" booklet 18:03-02).

The major part of the AC system troubleshooting does not require the use of a recycling station, only a thermometer, a dentist's mirror and a lamp.

Only when the fault has been isolated should the recycling station be fetched to enable draining of the system and rectifying the fault.

If the system has been open, e.g. in case of hose rupture, the AC system must be thoroughly cleaned.

When troubleshooting, the compressor will probably be engaged most of the time since the cooling capacity is so poor that the thermostat anti-freeze feature will rarely or never cut out.

## Wiring Diagrams

- Refer to wiring diagram 16:04-11 for AC electric system.
- Refer to wiring diagram 16:04-12 for ETC electric system.
- Refer to wiring diagram 16:04-13 for ETC/AC electric system.

Outline diagram - AC electric system:

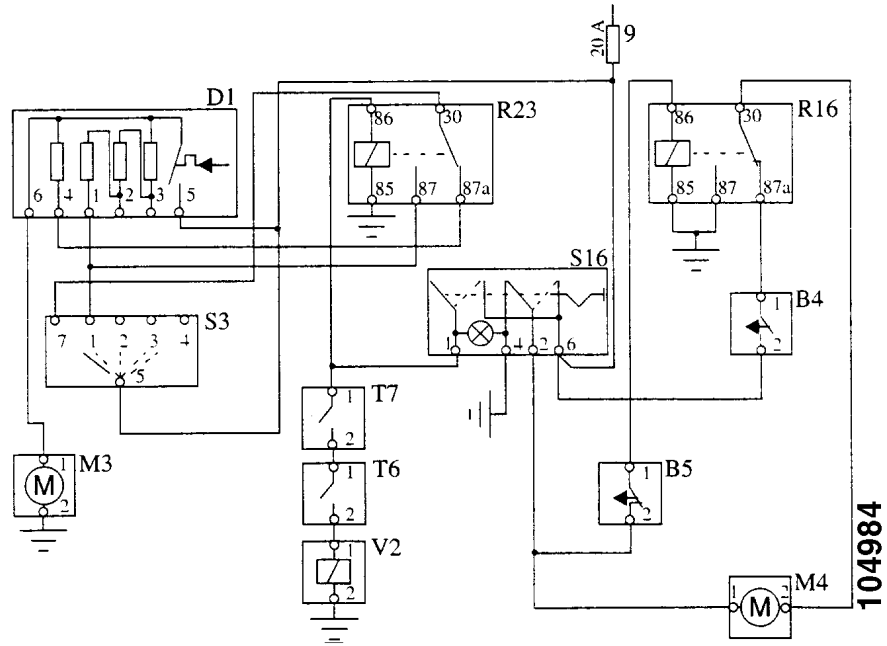

Outline diagram - AC electric system with separate recirculation:

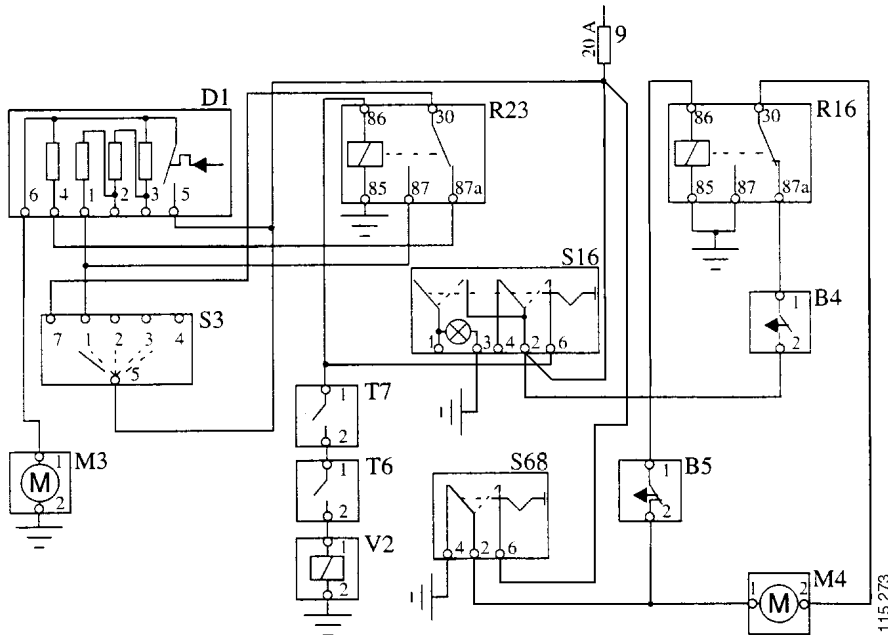

*B4 Confirmation switch*

*B5 Confirmation switch*

*D1 Fan resistor unit*

*M3 Fan motor*

*M4 Control motor*

*R16 AC relay*

*R23 Fan relay*

*S3 Fan switch*

*S16 AC switch*

*S65 Recirculation switch*

*T6 Pressure monitor*

*T7 Thermostat*

*V2 Clutch coil*

## Troubleshooting the cooling process

The pressures and temperatures stated greatly depend on the ambient temperature and humidity as well as the quantity of refrigerant present in the AC system. Thus, the pressures and temperatures should only be considered as recommendations, not as absolute values.

Start the engine, increase engine speed to 1,000 rpm and switch on the AC system.

**Tip:** In order to increase the compressor running time, either set the fan to max. speed and keep the cab doors open or set the fan to max. speed, set the temperature to max. and keep the doors closed.

**Note:** The temperatures are approximate and apply to an ambient temperature of 20 - 25°C.

**Hoses;** touch the rubber hoses to the SUC and DIS connections. The SUC hose shall feel frosty and the temperature of the DIS hose shall be 55 - 60°C.

**Dehydrator;** Check that the temperature is uniform, approx. 40°C, on the entire dehydrator.

On old vehicles, the dehydrator is equipped with an inspection glass. Observe the refrigerant through the inspection glass on top of the dehydrator using a dentist's mirror. If the refrigerant quantity is correct, the refrigerant should be liquid when passing through the dehydrator. In case of inadequate refrigerant quantity, the refrigerant will be entirely or partly gaseous. The refrigerant will then look "bubbly".

The most common faults in the AC system are caused by moisture, impurities or dust in the refrigerant circuit.

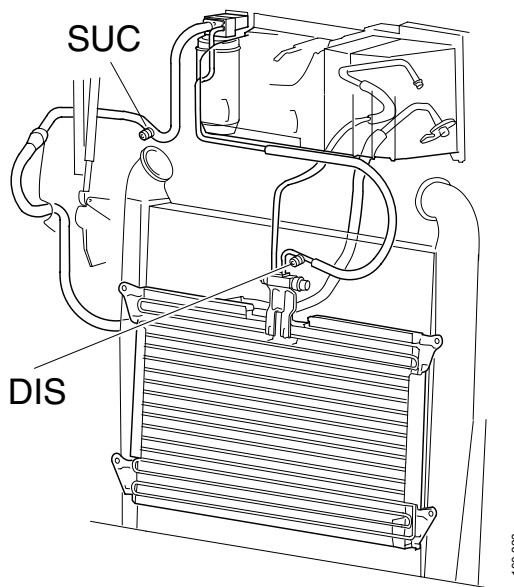

*Hose routing and service nipples, version 1*

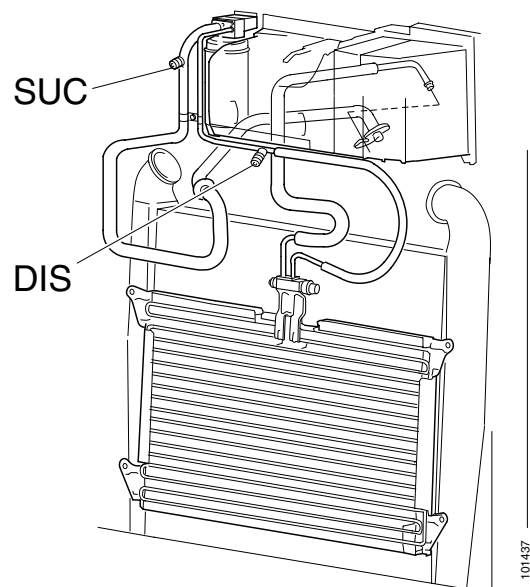

*Hose routing and service nipples, version 2*

## Troubleshooting without pressure gauge

Uneven cooling capacity is likely to be caused by moisture in the refrigerant, causing ice blockages. The dehydrator will then be saturated with moisture.

	SUC hose	Hose to condenser	Dehydrator / inspection glass	Compressor cylinder head
<b>REFRIGERANT**</b>				
Too much			Warm/clear	
Too little			Bubbly	
None			Clear	
<b>EXPANSION VALVE</b>				
Blocked*	Warm		Warm	
Jammed in open position	Very cold			
<b>DEHYDRATOR</b>				
Blocked			Unevenly warm	
<b>EVAPORATOR</b>				
Blocked	Cold			
<b>CONDENSER</b>				
Blocked		Warm		Hot
Contaminated		Warm		
<b>COMPRESSOR</b>				
Defective valves				Hot

\*) In case of very high pressures, above 31.4 bar, the pressure monitor will switch off the compressor. When the pressure has sunk below 31.4 bar, the compressor will be switched on and the pressure will start building up until the pressure monitor cuts out again. The compressor cycling intervals depend on the refrigerant quantity and the degree of blockage in the AC system.

\*\*\*) When in doubt as to the refrigerant level on vehicles without inspection glass, drain the system completely and refill the correct quantity.

## Troubleshooting with pressure gauge

- 1 Connect a pressure gauge set, or recycling station 587 627, to the high-pressure side (DIS) and the low-pressure side (SUC).
- 2 Start the engine and increase engine speed to 1,000 rpm.
- 3 Switch on the AC system.

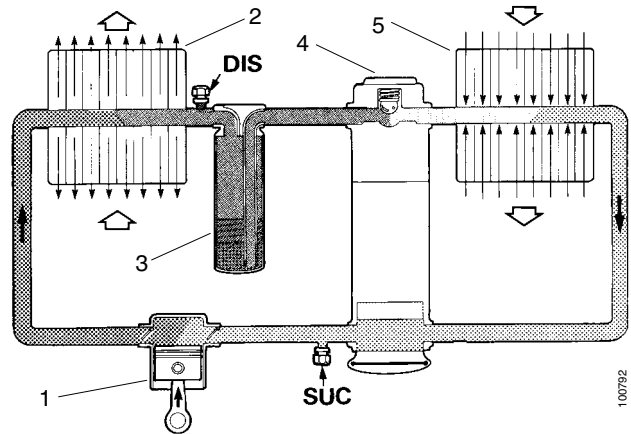

The pressure at the respective service nipples should be:

SUC: 1 - 2 bar

DIS: 7 - 17 bar

	SUC: Pressure: 1-2 bar	DIS: Pressure: 7-17 bar
Refrigerant		
Too much	Normal	High
Too little	Low	Low
Expansion valve		
Blocked	Low	High
Jammed in open position	Low	Low
Dehydrator		
Blocked	Low	High
Compressor		
Defective valves	High	Low
Condenser		
Blocked cooling fins	High	High