

SCANIA

19:01-07

Issue 2 en

Air horn

Function description, Work description and Retrofitting

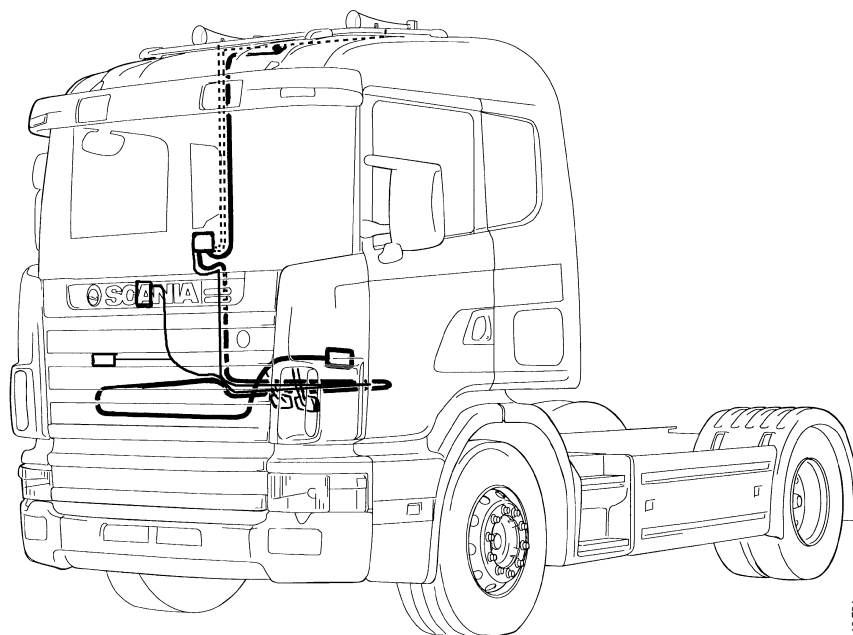

116 734

Contents

Function description	General	3
	Compressed air pipe	4
	Roof lead-in	6
	Electrical system.....	7
General	9
Retrofitting on vehicles factory prepared for air horns	Vehicles with roof bars	10
	Later version without roof bars	12
	Electrical connection	13
Retrofitting for vehicles that are not factory prepared for air horns	Short work description	14
	Removal of interior parts.....	14
Fitting	Solenoid valve for 14 cab	19
	Solenoid valve for 19 cab	20
	Making holes in the roof.....	21
	Air horns	23
	Routing of compressed air pipes and electrical cables	26
	Electrical system.....	30
	Finishing	31

Function Description

General

The air horns are accessories, available for right-hand drive as well as left-hand drive vehicles, and for all types of cab except Topline.

The air horns 5 are mounted on the roof bars or on alternative brackets if roof bars are not fitted. The air horns are driven by compressed air, supplied via the solenoid valve 2, from the compressed air system of the vehicle.

The solenoid valve, located on the right-hand side wall on RHD as well as LHD vehicles, is activated by the switch in the steering wheel provided that the switch 4 in the instrument panel is switched on. The air horns sound together with the regular horn of the truck.

Outline figure showing the routing off compressed air pipes and electrical cables for air horns

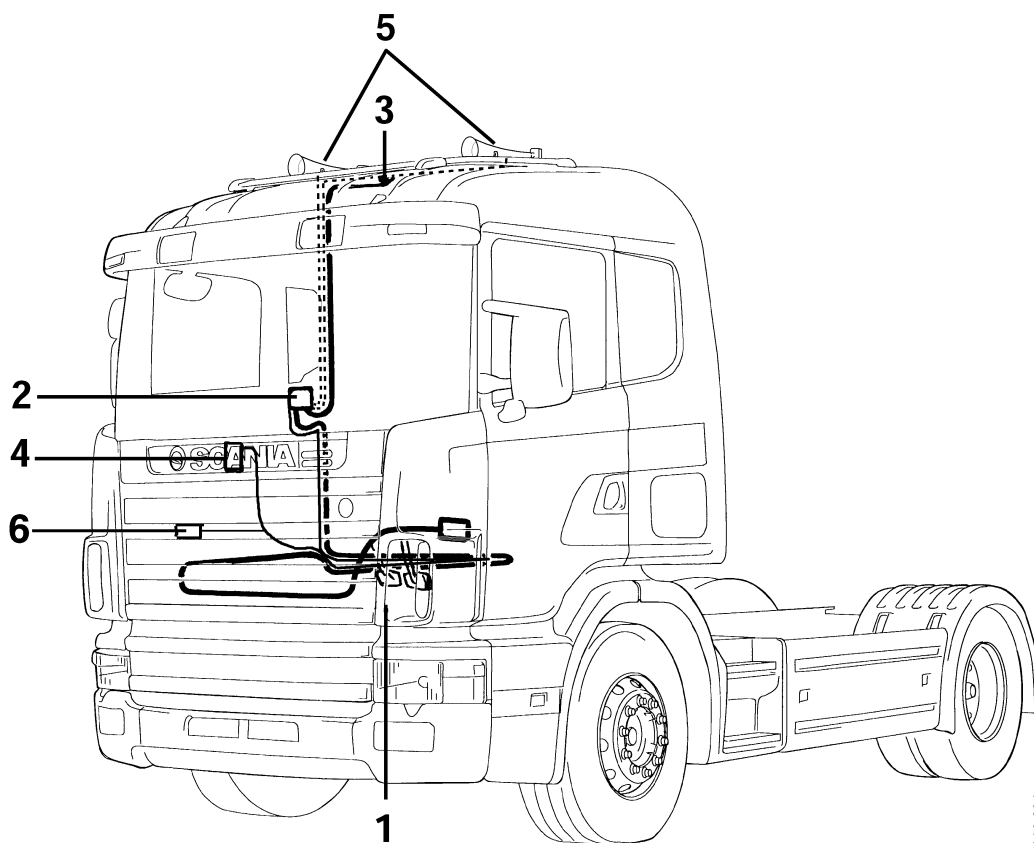

1 Manifold fitting

2 Solenoid valve

3 Roof lead-in with manifold fitting, earlier version

4 Switch S28

5 Air horns

6 Connector C12

---- Later version of pipe routing

116 234

Left-hand drive vehicle, 19 cab

Compressed air pipes

The compressed air is connected to a manifold fitting at the pedal mounting assembly and the pipe is marked XDE.

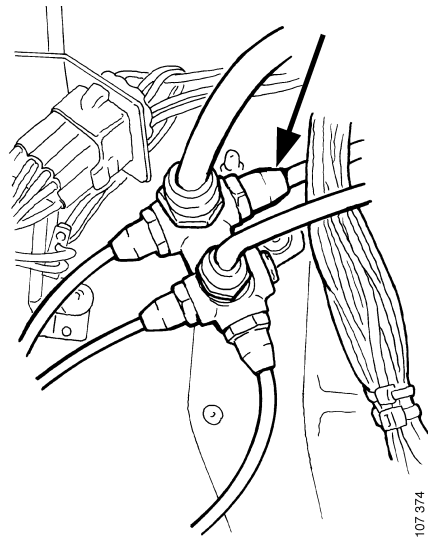

Compressed air pipe marked XDE, left-hand drive vehicle

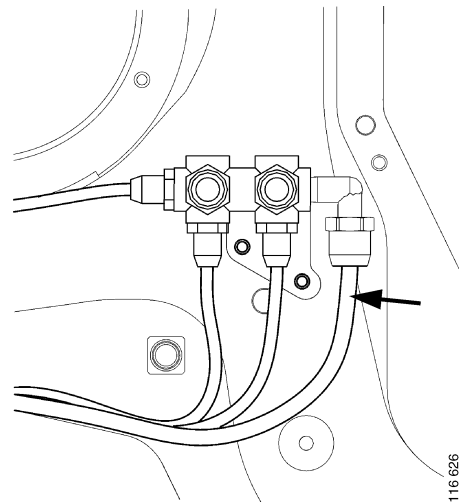

Compressed air pipe marked XDE, right-hand drive vehicle

From the pedal mounting assembly the pipe is routed below the instrument panel, rearwards on the engine tunnel and along the floor to the right-hand rear corner of the cab. From there the pipe is routed up to a solenoid valve located in the cab wall.

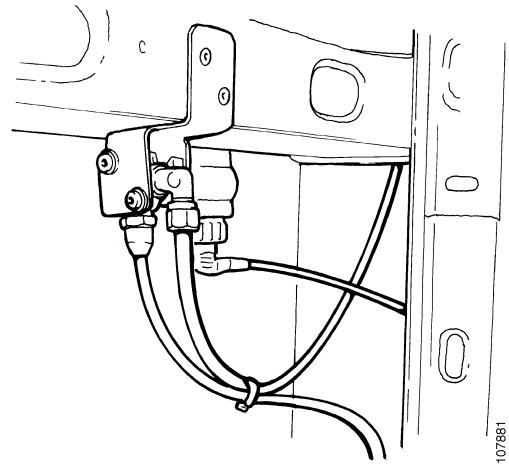

Solenoid valve in the cab wall, 19 cab, earlier version

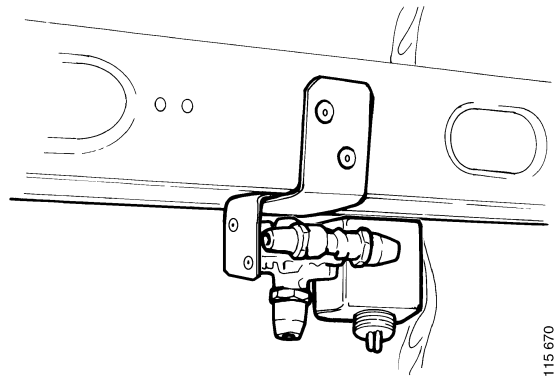

Solenoid valve in the cab wall, 19 cab, later version

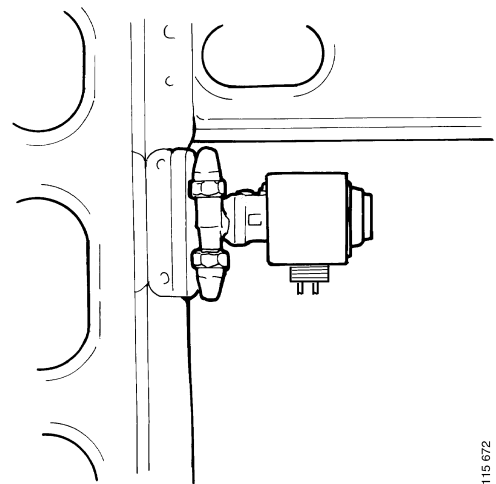

Solenoid valve in the cab wall, 14 cab

Roof lead-in

Earlier version, 19 cab only

On earlier versions the pipe is routed from the solenoid valve to a roof lead-in with a manifold fitting. The roof lead-in is welded to the roof from beneath and the manifold fitting has two O-rings to provide sealing against the roof.

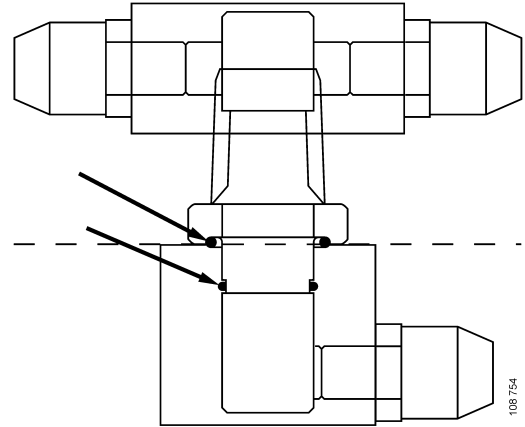

O-rings in the roof lead-in

The compressed air pipes are routed along the roof bars to the air horns.

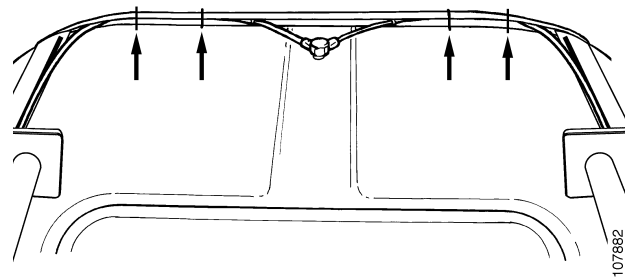

Later version, 14 and 19 cab

On later versions the T-pipe is located on the solenoid valve.

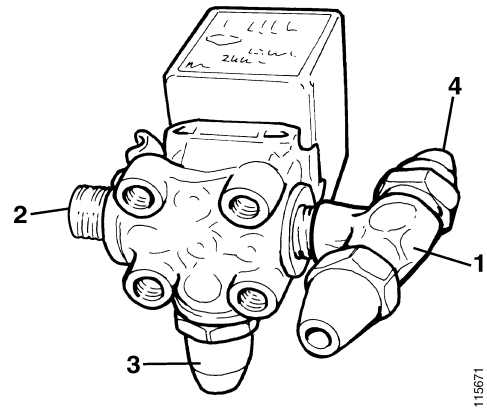

- 1 T-pipe
- 2 Plug
- 3 Union 8 mm
- 4 Union 6 mm

The pipes are routed to straight unions, located under the roof. From the unions, the pre-bent pipes are routed through rubber grommets in the roof to the air horns.

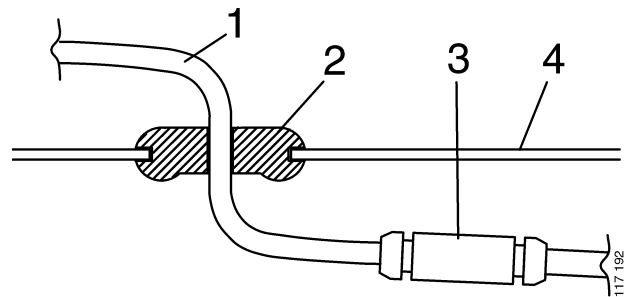

- 1 Compressed air pipe
- 2 Grommet
- 3 Straight union
- 4 Cab roof

Electrical system

The electrical cables are routed along the air pipe from the instrument panel, along the engine tunnel and the floor to the solenoid valve.

Air horns

General

The vehicle can be purchased factory prepared for air horns. The only actions required on such a vehicle are to fit the air horns to the roof, and connect the switch in the instrument panel.

If the vehicle is not factory prepared for air horns then a complete retrofit must be carried out.

Retrofitting on vehicles factory prepared for air horns

The work description applies to vehicles that are factory prepared for fitting of air horns. On such vehicles, the electrical cables, compressed air pipes and solenoid valve are already fitted.

Vehicles with roof bars

- 1 Fit a bracket 1 to each air horn.
- 2 Fit an elbow union 2 to each air horn. Use thread seal 561 019 and point the elbow union rearwards.

Tightening torque 10 Nm.

- 3 Fit a union 3 to each elbow union.

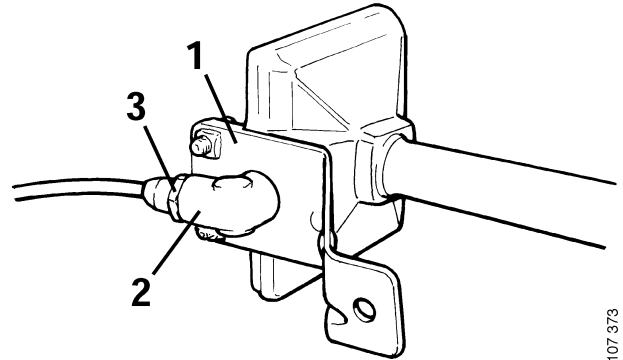

107 373

- 1 Bracket
- 2 Elbow union
- 3 Union

- 4 Fit two T slot bolts in each roof bar.
- 5 Fit the rubber protections to the front brackets and fit the air horns to the roof bars.

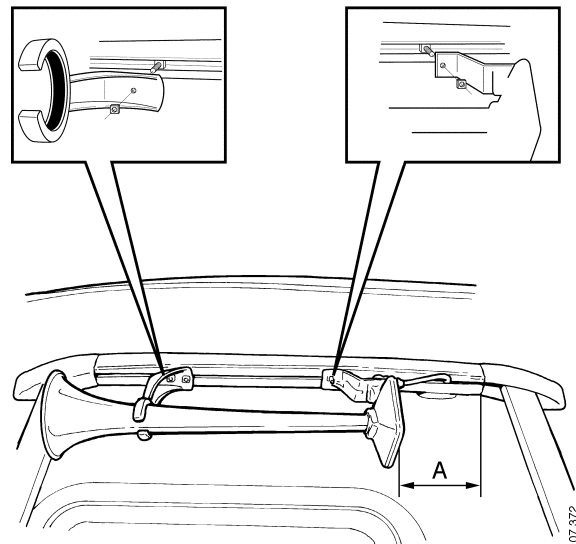

107 372

$A = 150 \text{ mm}$ for truck/tractor with 14 cab

$A = 410 \text{ mm}$ for truck with 19 cab

$A = 115 \text{ mm}$ for tractor with 19 cab

Earlier version, 19 cab

- 1 Remove the plugs from the manifold fitting.
- 2 Fit a quick-fit coupling to each outlet.
- 3 Fit two clamps to each roof bar.
- 4 Connect one end of a plastic pipe to the union in the manifold fitting. Route the pipe inside the rear cross bar and then to the air horn, securing with cable ties.
- 5 Cut the pipe to length and press it into the union on the air horn.
- 6 Check operation and check for leaks.

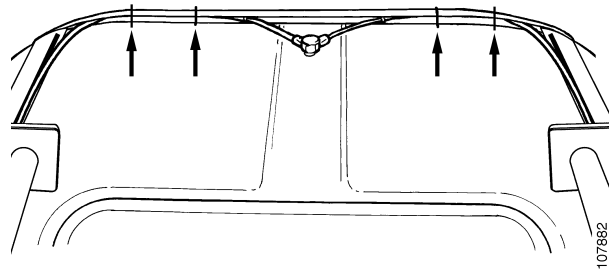

Clamping of plastic pipes

Later version, 19 cab and all 14 cabs

- 1 Detach the plug in the roof panel and gently lift up the plug, the straight union and the pipe.
- 2 Remove the plug and the pipe from the straight union and fit a pre-bent pipe with a rubber grommet.

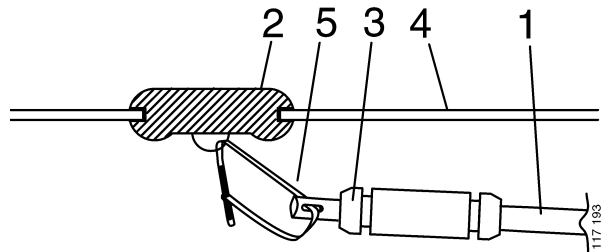

- 1 Pipe
- 2 Plug
- 3 Straight union
- 4 Cab roof
- 5 Cable tie

- 3 Connect the pre-routed pipe under the roof to the pre-bent pipe.
- 4 Fit the rubber grommet and pipe in the roof panel.
- 5 Cut the pre-bent pipe to length and connect it to the air horn.
- 6 Check operation and check for leaks.

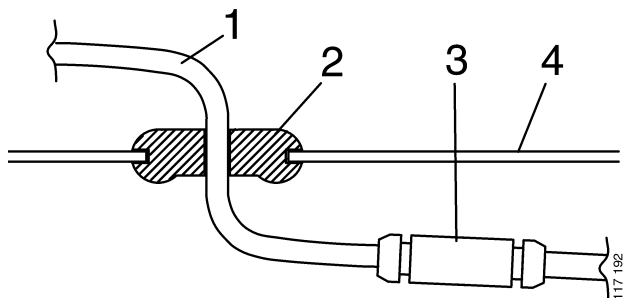

- 1 Compressed air pipe
- 2 Grommet
- 3 Straight union
- 4 Cab roof

Later version without roof bars

- 1 Fit the rubber protections 1 to the front brackets 2 and fit them to the roof brackets 3.
- 2 Fit the air horns and rubber feet 7 to the roof brackets 3.
- 3 Fit the elbow unions 4 and the unions 5 to the air horns. Use thread seal 561 019. Tightening torque for elbow unions 10 Nm.
- 4 Drill two mounting holes for each roof bracket where the panel is marked. First use a small drill and then a drill with a dimension of 7.0 mm. On the underside of the roof panel there are self-tapping nuts.
- 5 Fit the seals 6 between the roof brackets 3 and the roof panel, then fit the roof brackets 3.

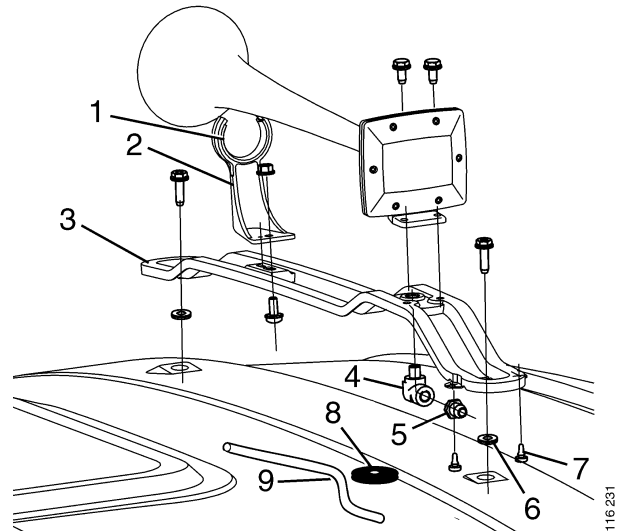

- 1 *Rubber protection*
- 2 *Front bracket*
- 3 *Roof Bracket*
- 4 *Elbow union*
- 5 *Union*
- 6 *Seal*
- 7 *Rubber foot*
- 8 *Grommet*
- 9 *Compressed air pipe*

- 6 Detach the plug in the roof panel and gently lift up the plug, the straight union and the pipe.
- 7 Remove the plug and the pipe from the straight union and fit a pipe with a rubber grommet.

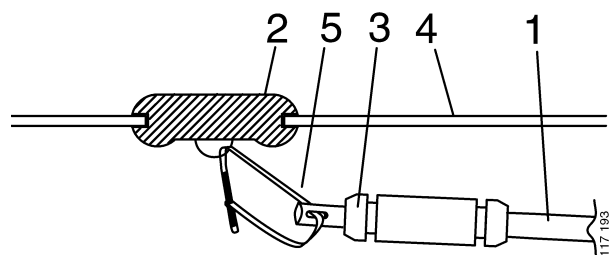

- 1 *Pipe*
- 2 *Plug*
- 3 *Straight union*
- 4 *Cab roof*
- 5 *Cable tie*

- 8 Connect the pre-routed pipe under the roof to the pre-bent pipe.
- 9 Fit the rubber grommet and pipe in the roof panel.
- 10 Cut the pre-bent pipe to length and connect it to the air horn.
- 11 Check operation and check for leaks.

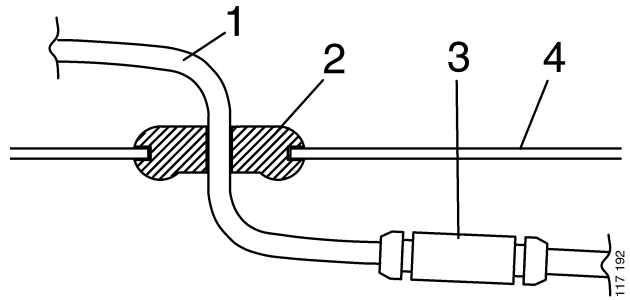

- 1 Compressed air pipe
- 2 Grommet
- 3 Straight union
- 4 Cab roof

Electrical connection

- 1 Remove the panel section concerned.
- 2 Fit the symbol plate for the air horn.
- 3 Fit the switch and connect it to the connector marked S28. The connector is clamped to the other cables behind the panel section.
- 4 Fit the panel section.

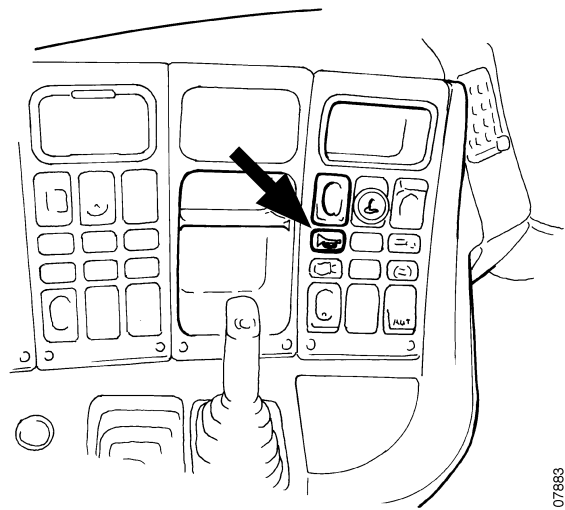

Retrofitting for vehicles that are not factory prepared for air horns

Short work description

Work carried out inside the cab

- Fitting the switch
- Routing the floor cable harness
- Fitting the solenoid valve
- Routing the compressed air pipes

Work carried out outside the cab

- Fitting the air horns
- Routing the pipes through the roof

Removal of interior parts

This description primarily applies to the CR19 cab with a low floor but some parts also apply to all cabs.

- 1 Pull out the storage box and remove the insert.
- 2 Remove the rear storage box cover, retained by two bolts at the front edge. Remove the rear storage box. It is secured by four bolts to the rear wall and two bolts at the front edge.
- 3 Remove the upholstery covering the centre console. It is fixed with velcro.

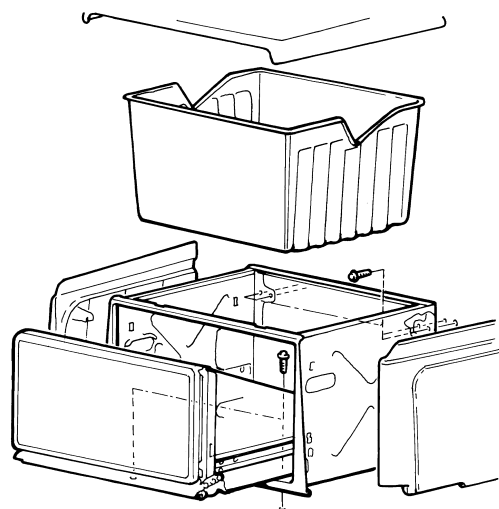

- 4 Remove the cover behind the driver's seat.
- 5 Remove the side of the storage box. Detach the heater hose on vehicles fitted with Eberspächer.

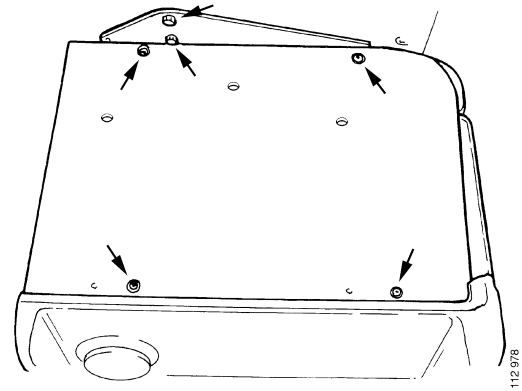

- 6 Slide the passenger seat to its rearmost position or tilt it. Detach the gas cylinder and secure the seat in the raised position with a support strut.

Note: The gas spring is locked with a metal strip!

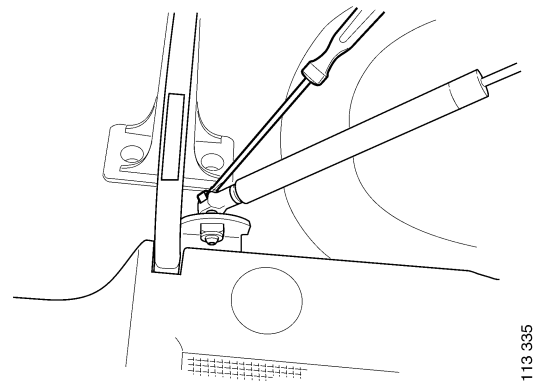

- 7 Remove the gas spring for the centre bed section and the section behind the passenger seat. Secure the bed in the raised position.

Note: Does not apply to elevated beds.

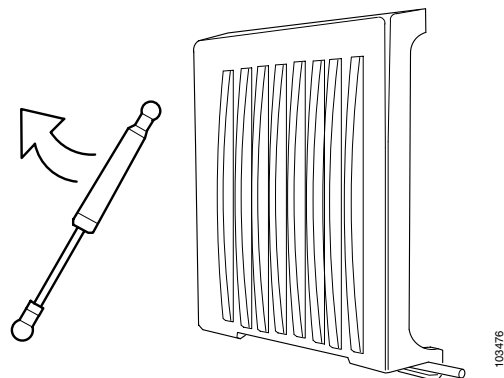

- 8 Remove the rear centre panel.

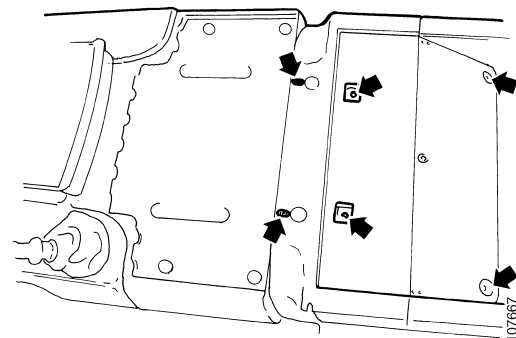

- 9 Remove the wood panel from the centre console.

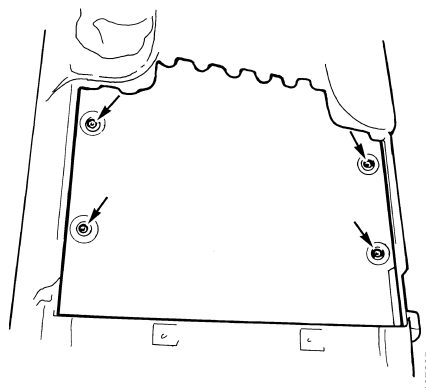

- 10 Remove the outer casing from the front storage box.

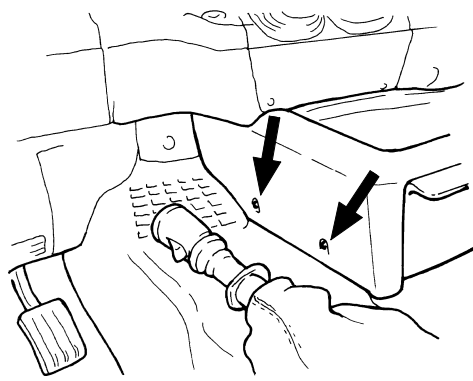

- 11 Pull out the box and remove the centre console retaining bolts.

- 12 Remove the bottle holder.

- 13 Remove the gear lever boot from the centre console.

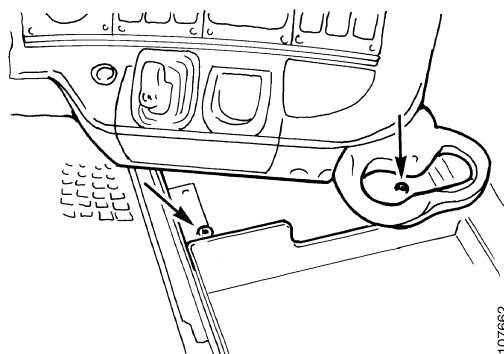

- 14 Remove the panel under the central electric unit and the panel under the centre section of the instrument panel.

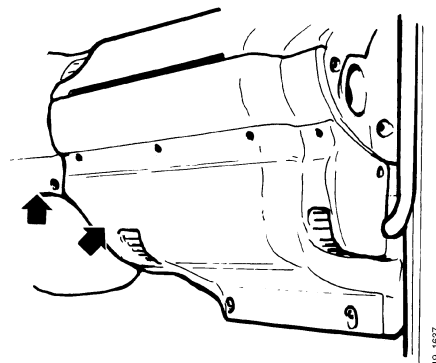

- 15 Remove the centre consoles A and B.
- 16 Remove the right-hand side kick strip
- 17 Remove the floor mounted support for the armchair.
- 18 Detach the rear wall.
In P cabs the rear wall should be removed.
- 19 Remove the right-hand side wall.
- 20 Remove the rear part of the headlining.

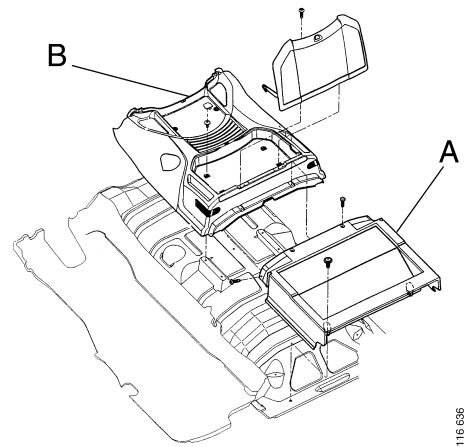
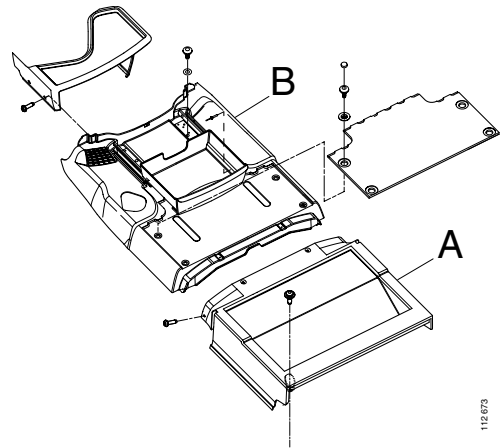

Type 14 cab

- 1 Remove the right-hand seat or the bench seat together with its storage box.
- 2 Remove any storage compartments from behind the right-hand seat or the bench seat.
- 3 Remove the side panels from above the doors.
- 4 Remove the panel on the right-hand side wall.
- 5 Detach the panel from the upper edge of the rear wall. In P cabs the rear wall should be removed.
- 6 Remove the frame from around the roof hatch if fitted, or undo the bolts securing the ceiling panel.
- 7 Detach the headlining from the centre and rearwards and lower slightly at the rear edge.

Fitting

The work description applies to vehicles that are not factory prepared for fitting of air horns.

Solenoid valve for 14 cab

- 1 Mark and drill $\varnothing 5$ mm holes for the solenoid bracket in the right-hand side wall.

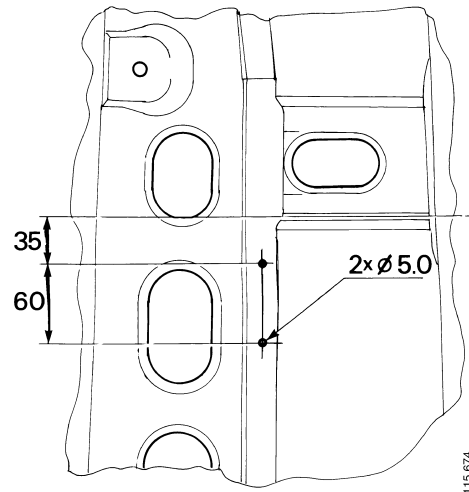

Hole layout for 14 cab

- 2 Fit the T-pipe with the 6 mm and 8 mm unions and the plug.

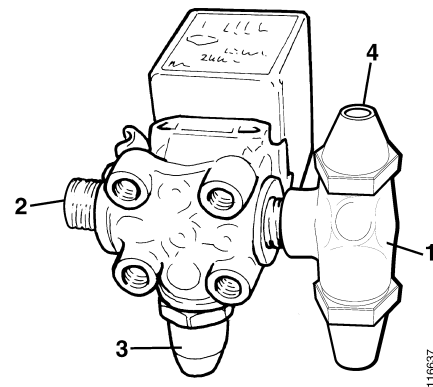

- 1 *T-pipe*
- 2 *Plug*
- 3 *Union 8 mm*
- 4 *Union 6 mm*

- 3 Fit the bracket to the solenoid valve using M6x12 bolts.
- 4 Fit the solenoid valve and its bracket using blind rivets.

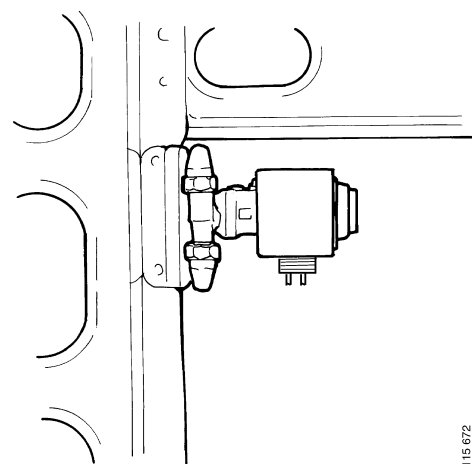

Location of solenoid valve in 14 cab

Solenoid valve for 19 cab

- 1 Drill two new $\text{\O} 5.0$ mm holes in the solenoid valve bracket.
- 2 Drill corresponding $\text{\O} 5.0$ mm holes in the right-hand side wall.

IMPORTANT! The bracket should be positioned 60 mm behind the existing $\text{\O} 6$ mm hole.

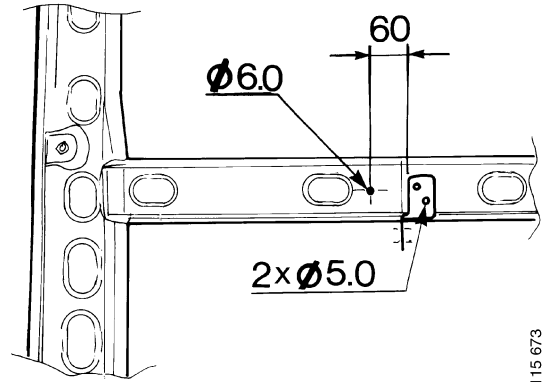

115 673

Hole layout for 19 cab

- 3 Fit the T-pipe with the 6 mm and 8 mm unions and the plug.

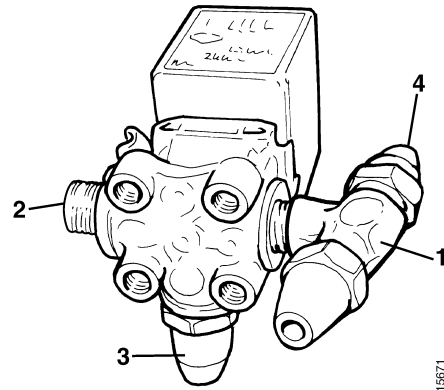

115671

- 1 *T-pipe*
- 2 *Plug*
- 3 *Union 8 mm*
- 4 *Union 6 mm*

- 4 Fit the bracket to the solenoid valve using M6x12 bolts. Use two diagonal holes.
- 5 Fit the solenoid valve and its bracket using blind rivets.

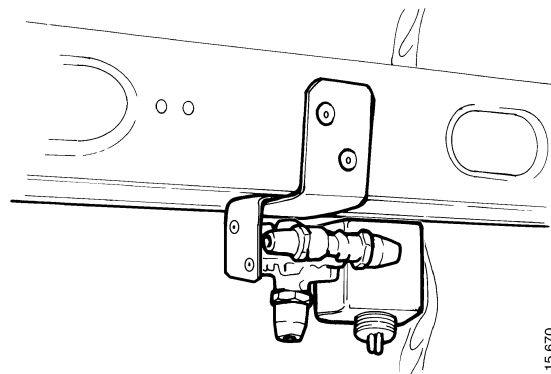

115 670

Location of solenoid valve in 19 cab

Making holes in the roof

- 1 Measure the position of a hole for the compressed air pipes in the roof, behind the air horns, according to the illustration.

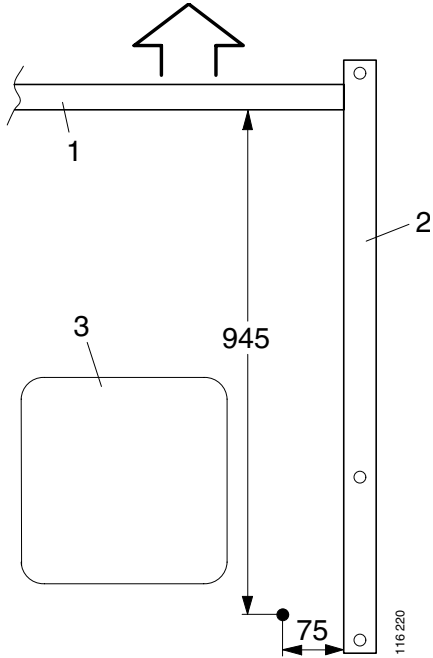

- 1 Roof bar
 - 2 Roof bar
 - 3 Roof hatch
- 14 cab with roof bars

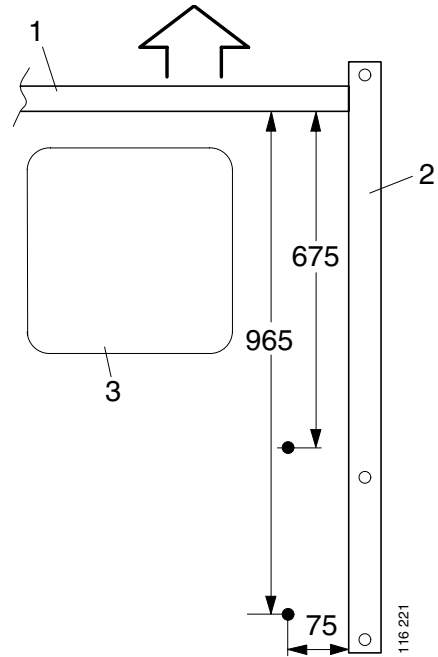

- 1 Roof bar
 - 2 Roof bar
 - 3 Roof hatch
- 675 = Dimension for tractor
965 = Dimension for truck
19 cab with roof bars

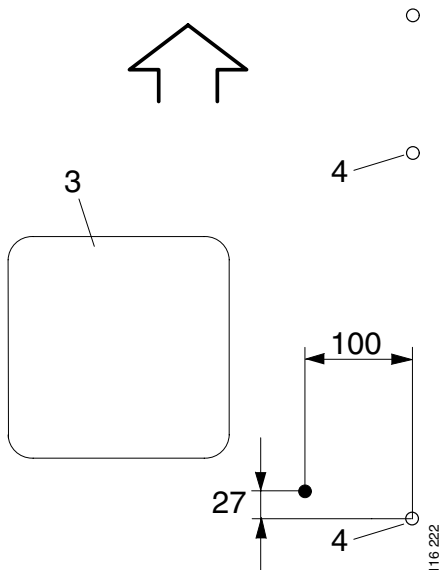

- 3 Roof hatch
 - 4 Mounting holes for roof brackets
- 14 cab without roof bars

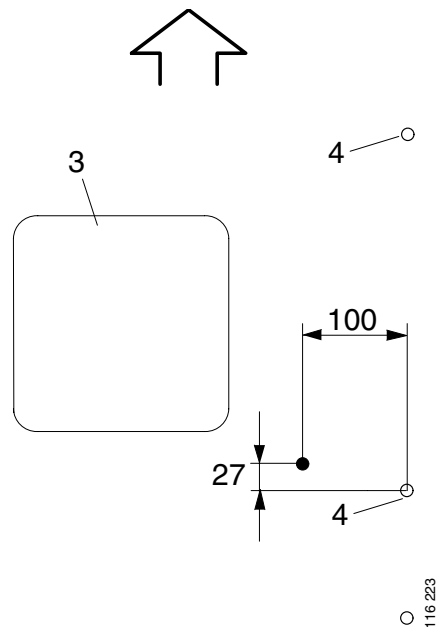

- 3 Roof hatch
 - 4 Mounting holes for roof brackets
- 19 cab without roof bars

- 2 Drill a pilot hole using a $\text{\O} 5.0$ mm and then make the $\text{\O} 15$ mm holes using a tank cutter or a hole saw.

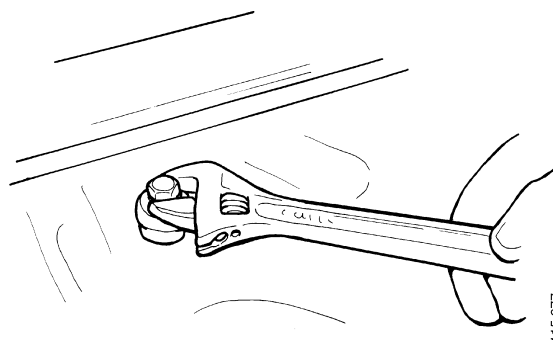

- 3 Fit the grommets into the holes.

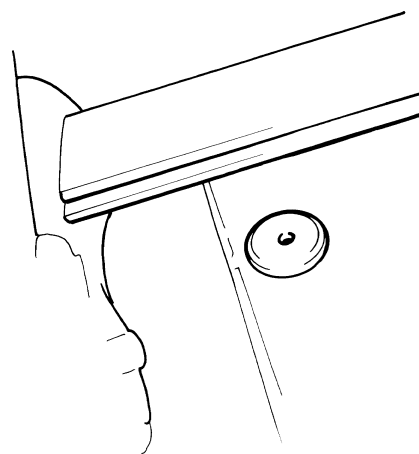

Air horns

Roof bracket for vehicles with roof bars

- 1 Fit a bracket 1 to each air horn.
- 2 Fit an elbow union 2 to each air horn. Use thread seal 561 019 and point the elbow union rearwards. Tightening torque 10 Nm.
- 3 Fit a union 3 to each elbow union.

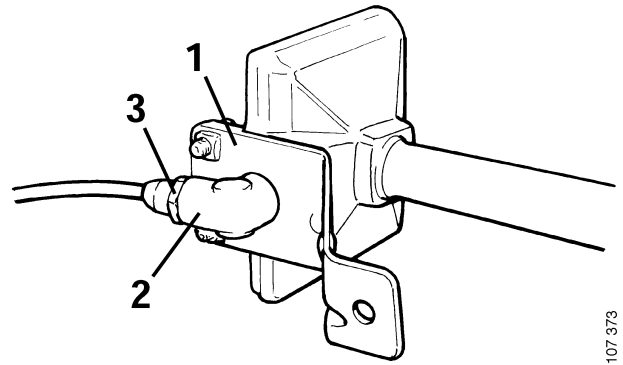

107.373

- 1 Bracket
- 2 Elbow union
- 3 Union

- 4 Fit two T slot bolts in each roof bar.
- 5 Fit the rubber protections to the front brackets and fit the air horns to the roof bars.

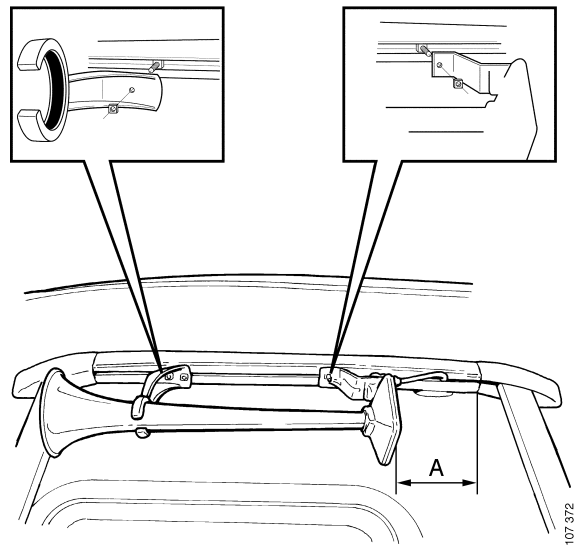

107.372

A = 150 mm for truck and tractor with 14 cab

A = 410 mm for truck with 19 cab

A = 115 mm for tractor with 19 cab

- 6 Insert the pre-bent compressed air pipes through the rubber grommets.

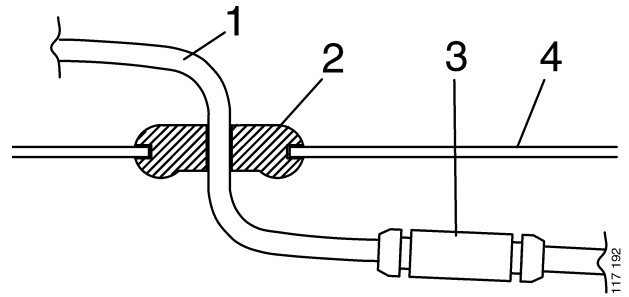

- 1 Compressed air pipe
- 2 Grommet
- 3 Straight union
- 4 Cab roof

- 7 Cut the compressed air pipes to length and insert them into the unions on the air horns, the pipes engage automatically.

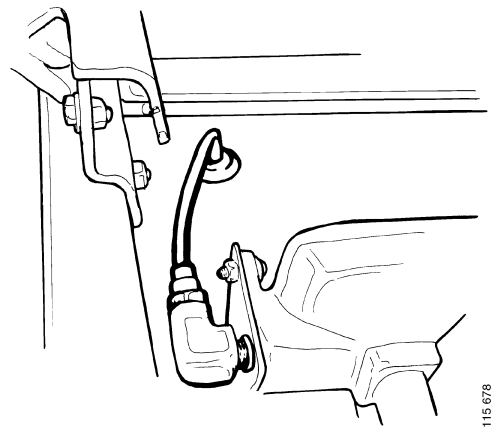

Roof bracket for vehicles without roof bars

- 1 Fit the rubber protections 1 to the front brackets 2 and fit them to the roof bracket 3.
- 2 Fit the air horns and rubber feet 7 to the roof brackets 3.
- 3 Fit the elbow unions 4 and the unions 5 to the air horns. Use thread seal 561 019. Tightening torque for elbow unions 10 Nm.
- 4 Drill two mounting holes for each roof bracket where the panel is marked. First use a small drill and then a drill with a dimension of 7.0 mm. On the underside of the roof panel there are captive nut strips for self tapping screws.
- 5 Fit the seals 6 between the roof brackets 3 and the roof panels, then fit the roof brackets 3.

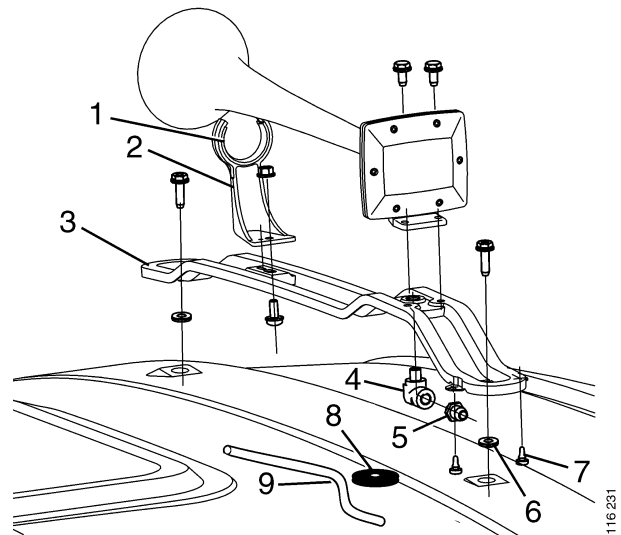

- 1 *Protection strip*
- 2 *Front bracket*
- 3 *Roof Bracket*
- 4 *Elbow union*
- 5 *Union*
- 6 *Seal*
- 7 *Rubber foot*
- 8 *Grommet*
- 9 *Compressed air pipe*

- 6 Insert the pre-bent compressed air pipe through the rubber grommets.

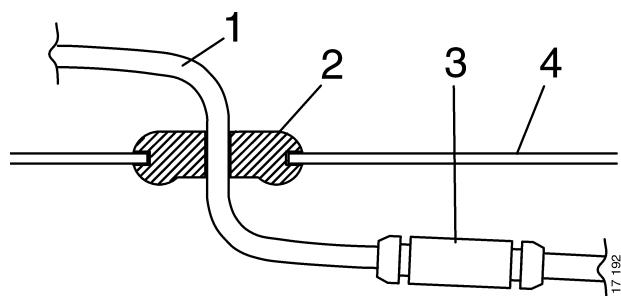

- 1 *Compressed air pipe*
- 2 *Grommet*
- 3 *Straight union*
- 4 *Cab roof*

- 7 Cut the compressed air pipes to length and insert them into the unions on the air horns, the pipes engage automatically.

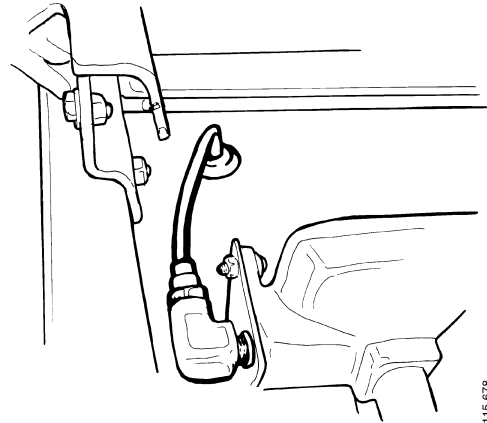

Routing of compressed air pipes and electrical cables

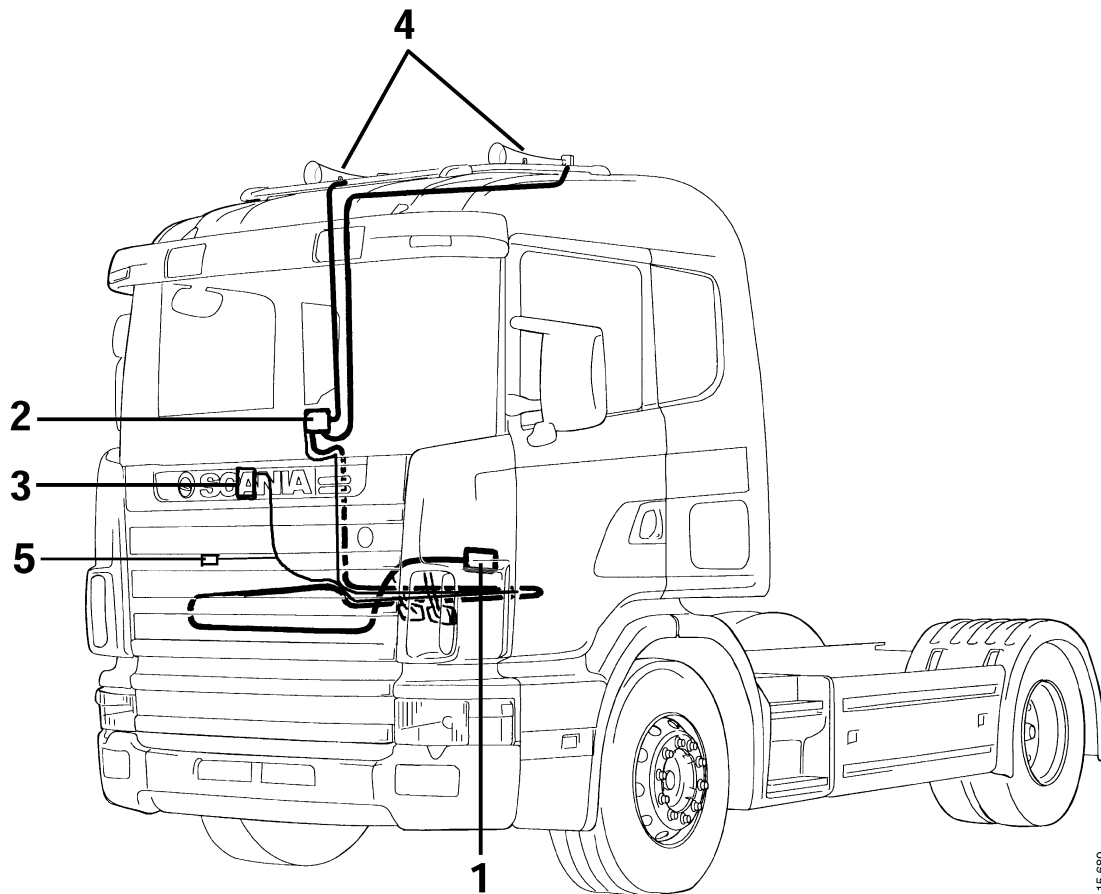

- 1 *Manifold fitting*
- 2 *Solenoid valve*
- 3 *Switch S28*
- 4 *Air horn*
- 5 *Connector C12*

Outline figure showing the routing off compressed air pipes and electrical cables, LHD 19 cab.

- 1 Fit the insert connections on the inside of the cab, fit the compressed air pipes and route them along the rear wall down to the solenoid valve. Secure the compressed air pipes to the rear wall using self-adhesive clamps. If only one pipe is secured in a clamp, cut an approx. 4 cm long piece of compressed air pipe and also secure that in the clamp, this will reduce the risk of disturbing vibration noise.

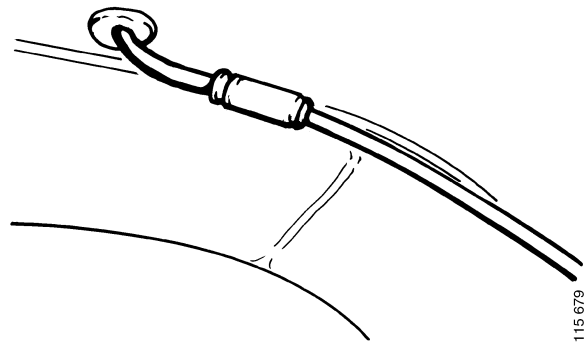

IMPORTANT! Clean the areas for attaching the self-adhesive clamps using methyl alcohol or similar. Do not touch the adhesive surfaces!

- 2 Cut the compressed air pipes to length and insert them into the unions on the solenoid valve, the pipes engage automatically.
- 3 Route a compressed air pipe from the solenoid valve down to the floor.
- 4 Fit the chafe protection and make an opening in the side panel for the cables and the pipe. Make an opening in the rear wall in a P cab

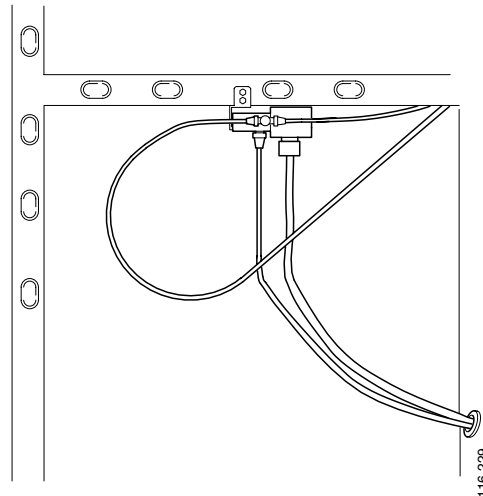

- Route the compressed air pipe along the floor and the engine tunnel to the manifold fitting under the pedal mounting assembly. On 14 cabs the routing is the same as in a 19 cab although the longitudinal section before the rear wall is shorter.

Note: Route the pipe so that it cannot be chafed or trapped by the pedal mounting assembly.

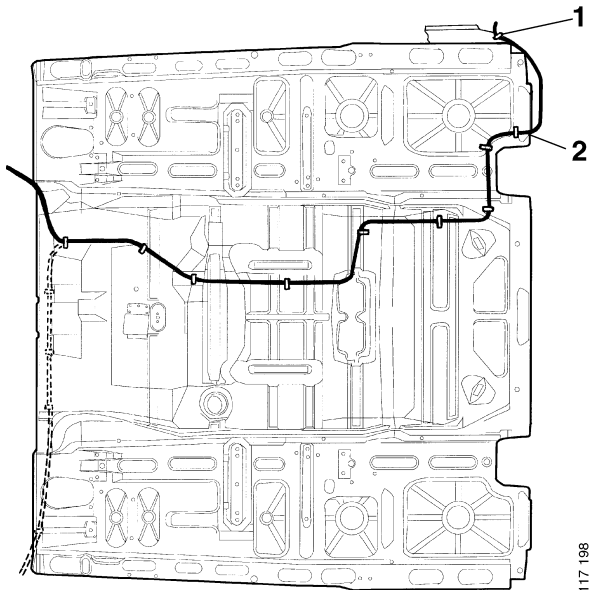

- 1 Floor clamp
 - 2 Cab wall opening
- CP 19 cab

117 198

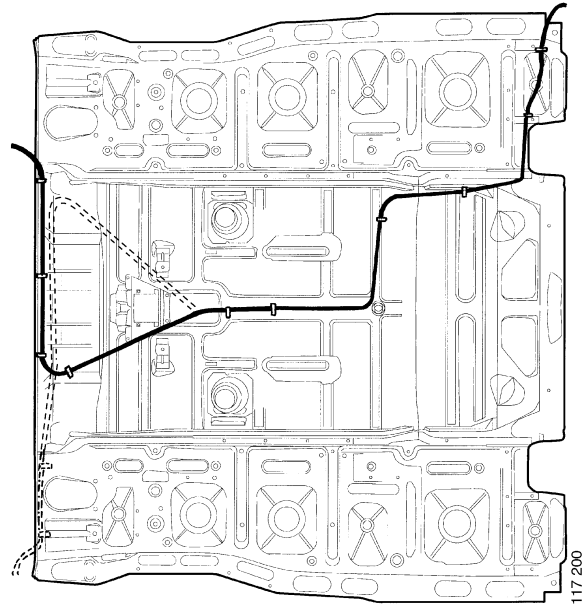

117 200

CR 19 cab

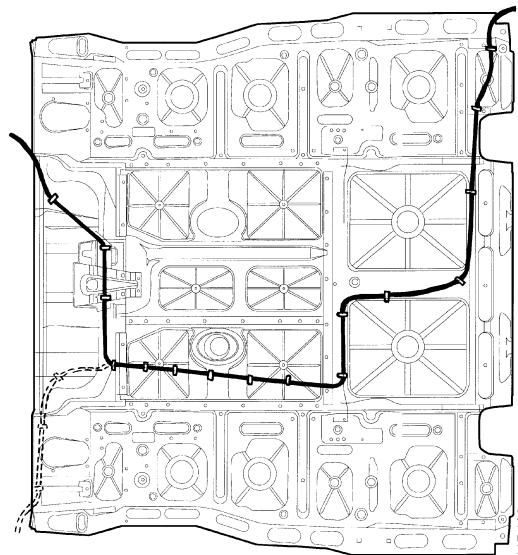

117 199

CT 19 cab

— pipe routing on right-hand drive vehicles
 --- pipe routing on left-hand drive vehicles

- 6 Insert the pipe into the manifold fitting at the pedal mounting assembly.

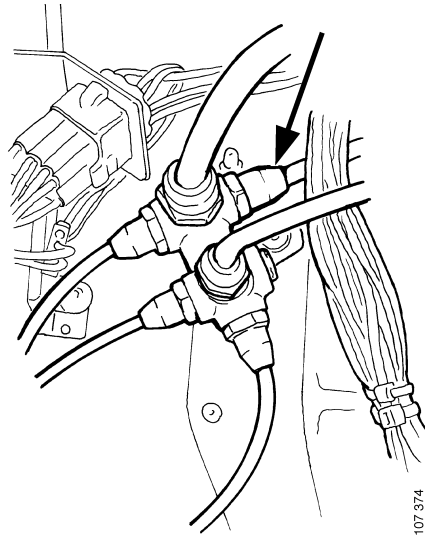

Compressed air pipe marked XDE, left-hand drive vehicles

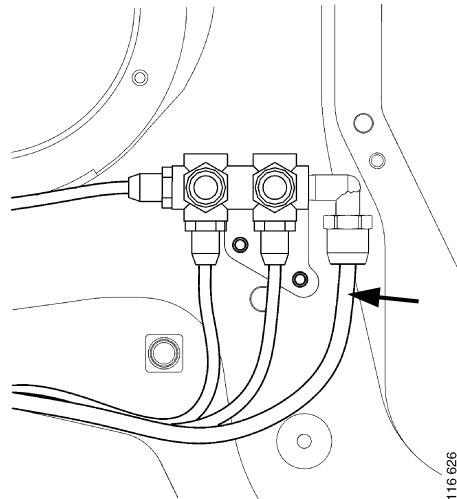

Compressed air pipe marked XDE, right-hand drive vehicles

Electrical system

- 1 Connect the electrical cable to the solenoid valve and route it together with the compressed air pipe along the engine tunnel to the connector panel below the central electric unit.
- 2 Connect the cables 15KG (BN) to position 8 and H (GY) to position 9 in the connector panel C12.

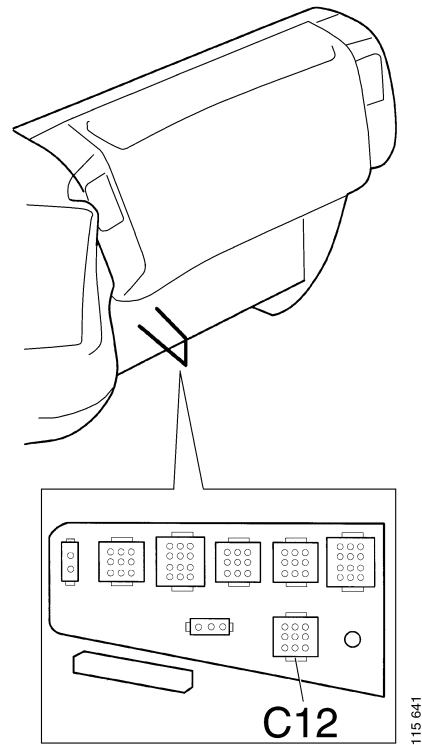

- 3 Remove the panel section concerned.
- 4 Fit the symbol plate for the air horn.
- 5 Fit the switch and connect it to the connector marked S28. The connector is clamped to the other cables behind the panel section.
- 6 Fit the panel section.
- 7 Check operation and check for leaks before refitting the interior trim.

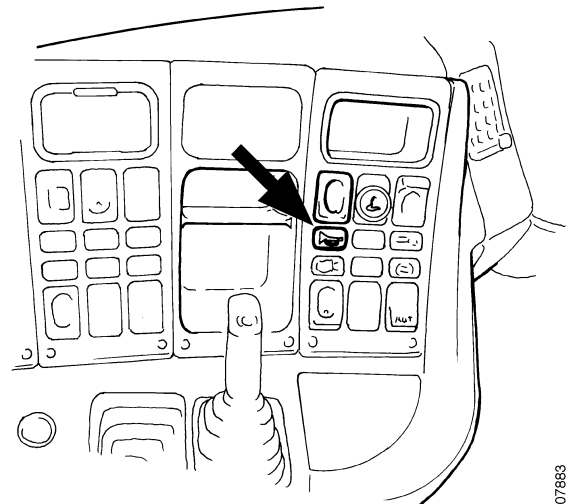

Connection diagram

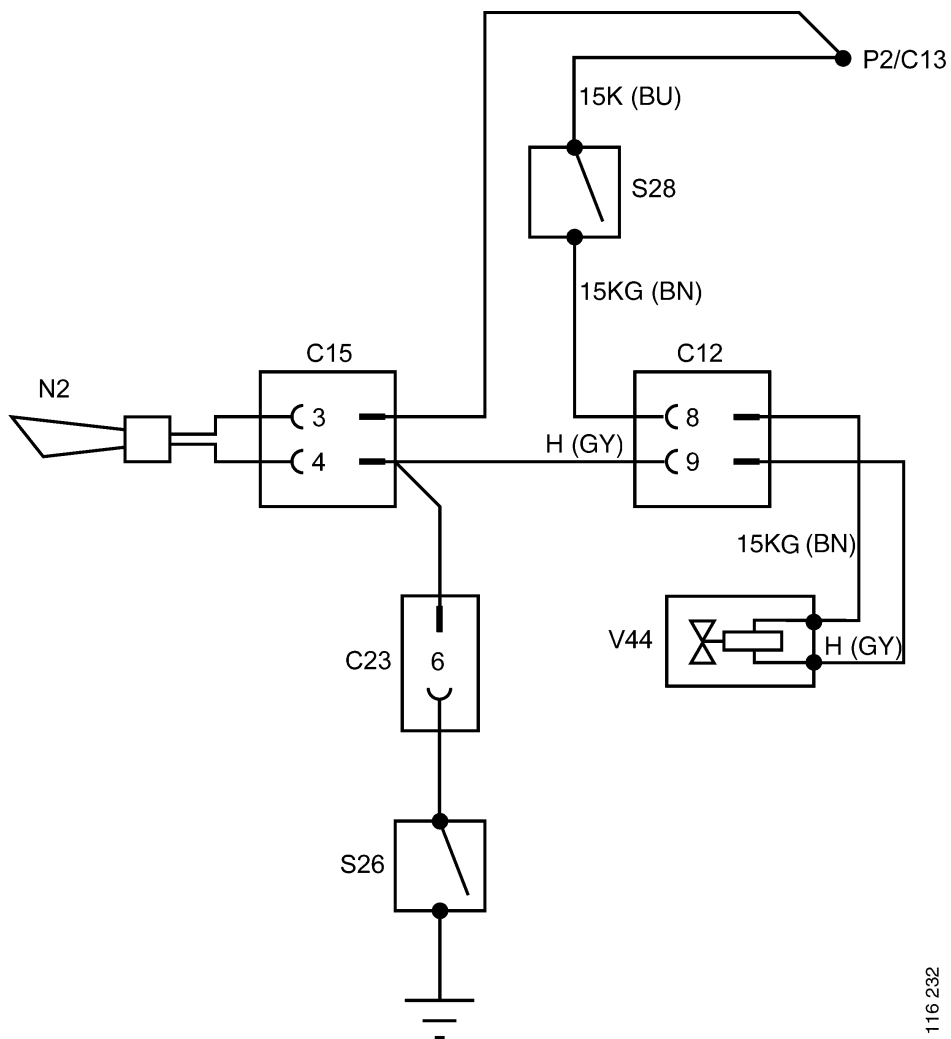

116 232

S26 Coil spring connector in the steering wheel

S28 Switch for air horn

V44 Solenoid valve for air horn

N2 Horn

Finishing

- 1 Clamp the electrical cables and the compressed air pipes.
- 2 Refit all covers and panels.