

SCANIA

19:02-05

Issue 2 **en**

Retrofitting of refrigerator

Work Description

18 litre

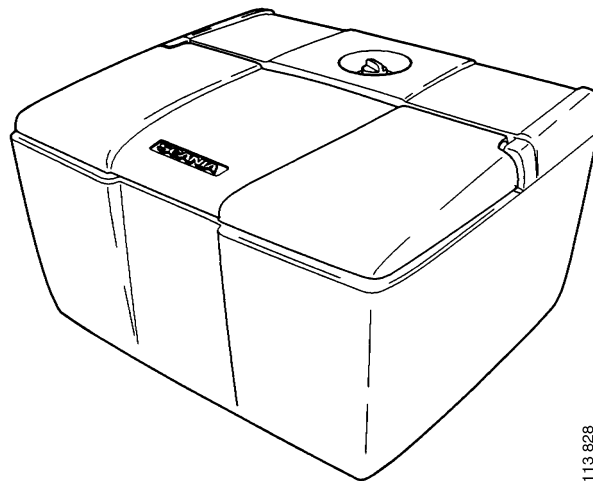

113 828

Contents

General 3

Removal of interior parts 4

Cable routing 6

Fitting the refrigerator under the bed, Alt 1a 8

Fitting the refrigerator under the bed, Alt 1b 12

Fitting the refrigerator under the folding armchair Alt 2 15

Fitting refrigerator in extendable rear centre storage box Alt 3 21

Fitting refrigerator behind driver's seat Alt 4 24

Refrigerator

General

This refrigerator is an original Scania accessory for keeping food cool. It has been specially manufactured for Scania and a number of places in the cab are prepared for it.

Location in the cab depends on cab type and equipment options.

The illustrations featured in this description are based on the LHD R19 cab. Converse fitting applies to right-hand drive vehicles.

For refrigerator function and repairs, see main group 19, Refrigerator, Function and work description.

The following locations are possible on CT and CR cabs with low-level floor:

Alt. 1a Refrigerator under bed, suitable for the following cab types

- CR19 and CR19T with raised bed position but without passenger sliding seat.
- CR19 and CT19 with one or two beds, without passenger sliding seat.

Alt. 1b

- CT19 under centre section of bed.

Alt. 2 Refrigerator under folding armchair, suitable for the following cab types

- All CR19 and CR19T cabs with folding armchair.

Alt. 3 Refrigerator in extendable rear centre storage box

- All vehicles with extendable rear centre storage box.

Alt. 4 Refrigerator behind driver's seat

- CR19 and CR19T with raised bed position but not equipped with Satcom.

Removal of interior parts

This description is generally applicable to CR cabs with low floor and should be used where relevant.

- 1 Pull out the storage box and remove the insert.
- 2 Remove the rear storage box cover, connected to the front edge with two bolts. Remove the side panels on the storage box. Remove the rear storage box. It is secured by four bolts to the rear wall and two bolts in the front edge.
- 3 Remove the upholstery covering the centre console. It is fixed with velcro.

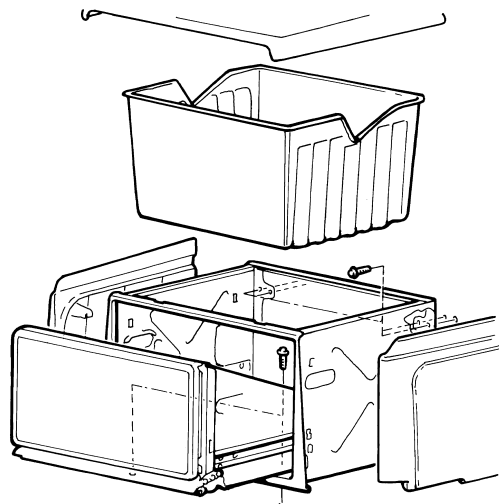

- 4 Remove the cover behind the driver's seat.
- 5 Remove the side of the storage box. Detach the heater hose on vehicles fitted with Eberspächer.

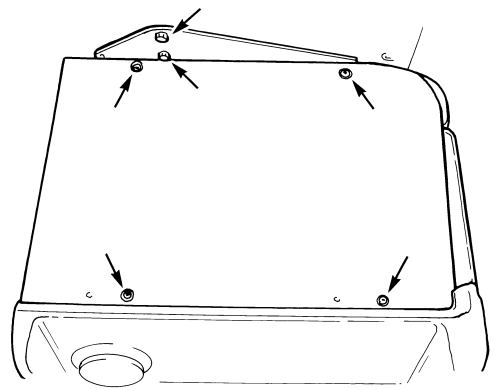

- 6 Slide the passenger seat to its rearmost position or tilt it. Detach the gas spring and secure the seat in raised position with a strut.

Note: The gas spring is locked with a metal strip!

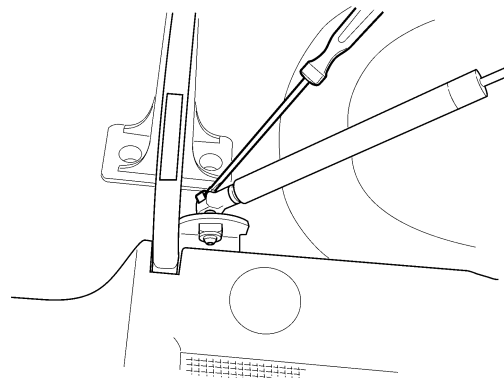

- 7 Remove the gas springs for the centre bed section and the bed section behind the passenger seat. Secure the bed in the raised position.

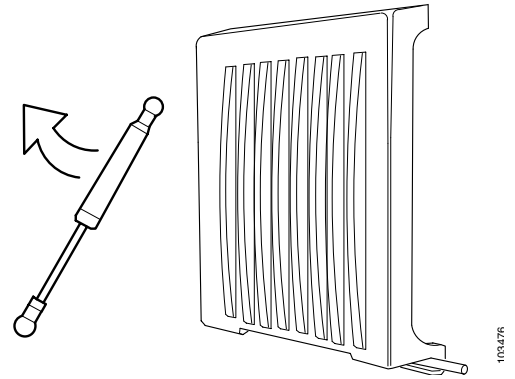

- 8 Remove the wood panel from the centre console.

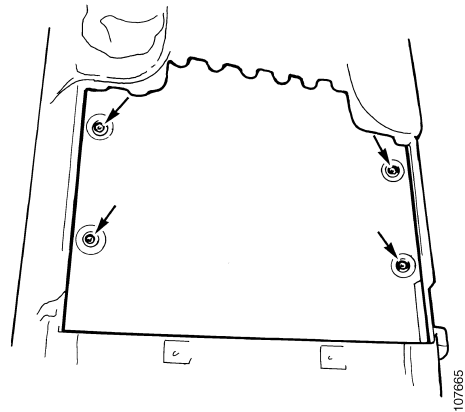

- 9 Remove the rear centre panel.

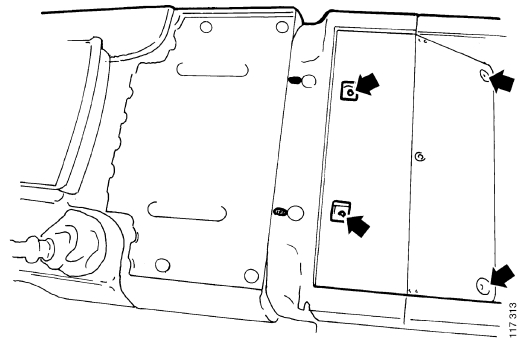

- 10 Remove the panel under the central electric unit and the panel under the centre section of the instrument panel.

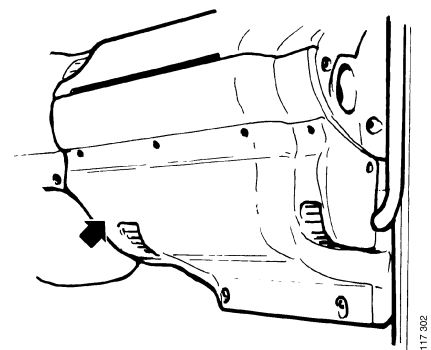

Cable routing

Instrument cable harness

- 1 Remove fuse 35.

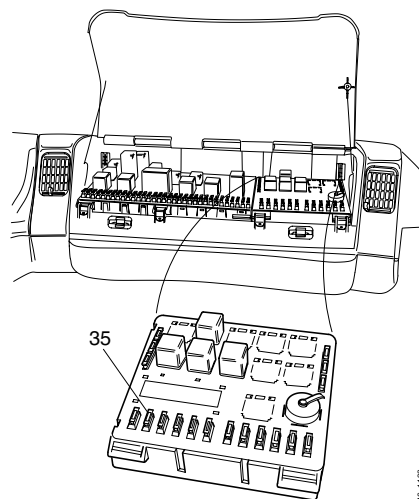

- 2 Connect the orange cable between the central electric unit F1/35-C and C124 pin 3 in the connector panel on the left under the central electric unit. If the vehicle is not equipped with manual exhaust brake then the connector must also be fitted.

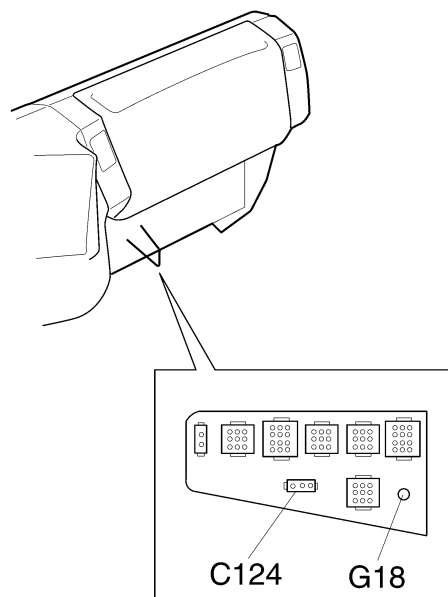
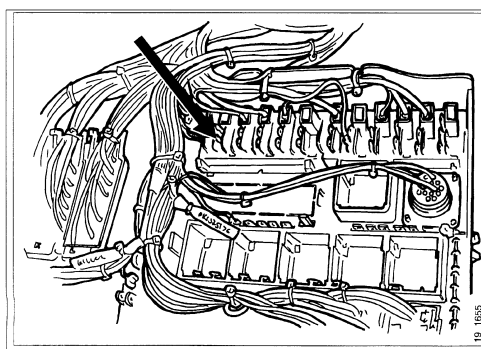

Floor cable harness

1 Route the floor cable harness under the centre console as illustrated to the intended location of the refrigerator.

- Alt. 1 Refrigerator under bed
- Alt. 2 Refrigerator under folding armchair
- Alt. 3 Refrigerator in extendable centre storage box
- Alt. 4 Refrigerator behind driver's seat

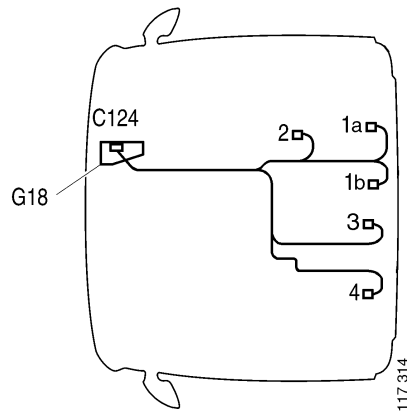

2 Connect cable 30G (OG) to C124 pin 3 and cable 31 (BK) to G18.

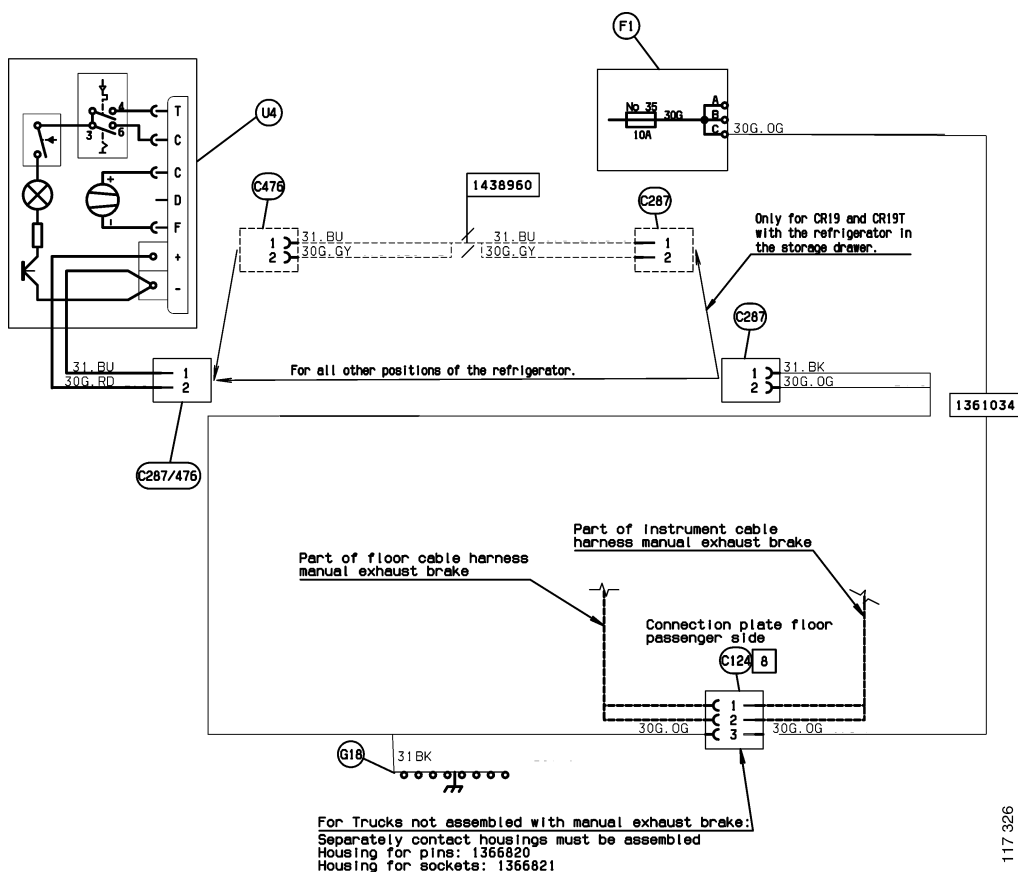

Fitting the refrigerator under the bed, Alt. 1a

- 1 Remove the bed support.
- 2 Fold the floor mat out of the way.
- 3 Remove the insulation over four prepared screw holes and increase thread to M10.

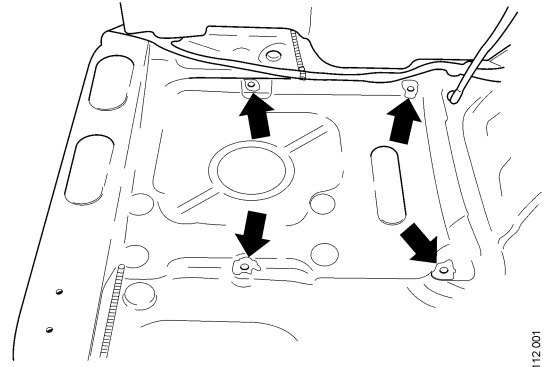

- 4 Fold the floor mat back into place and mark the location of the holes. The two holes closest to the engine tunnel are already marked. Use the mounting plate as a template for the other holes.

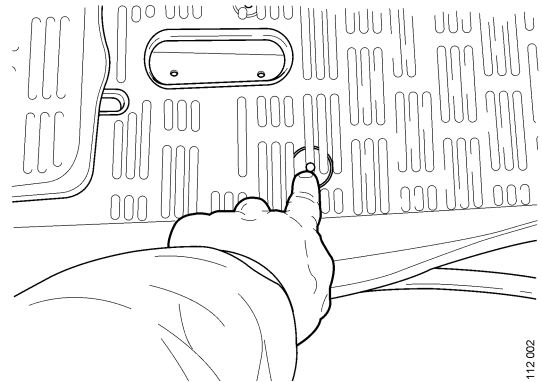

- 5 Make five holes in the floor mat for the spacers as shown in the figure.

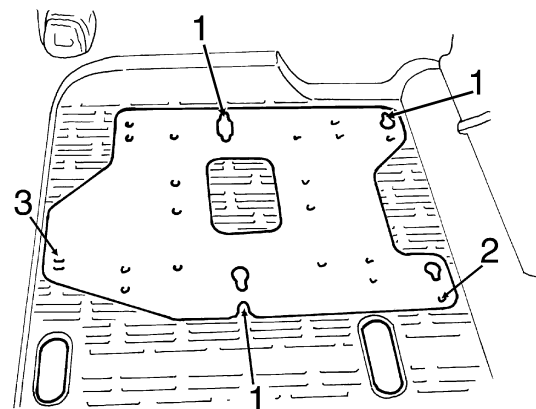

- 1 Spacer, Ø 27 mm, length 23 mm
- 2 Spacer, Ø 21 mm, length 20.5 mm
- 3 Spacer, Ø 16 mm, length 17.5 mm

- 6 Fit three spacers, diameter 27 mm, using a 10.5 mm washer and M10x60 bolts.

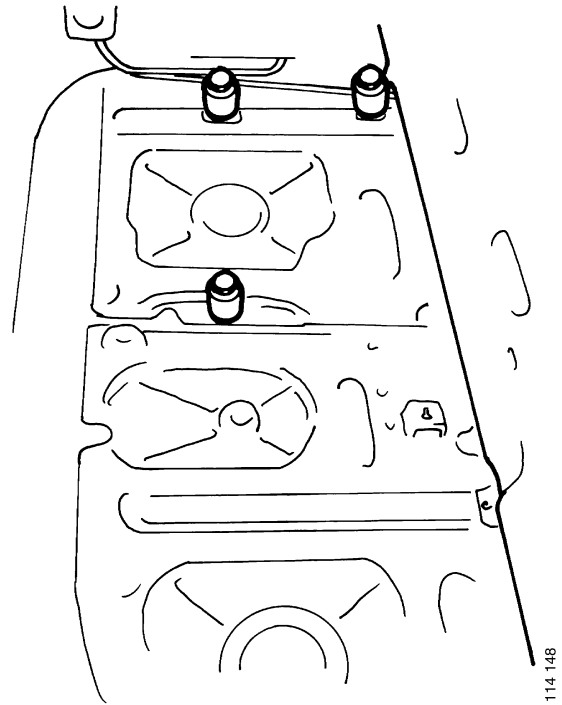

- 7 Position the refrigerator with the rear facing downwards. Fit the mounting plate underneath using four special screws.

Note: The refrigerator must not be turned upside down.

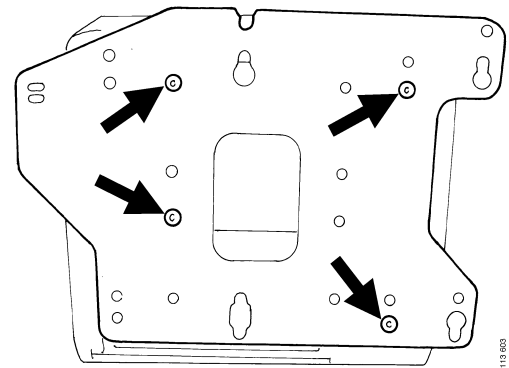

Left hand drive vehicles

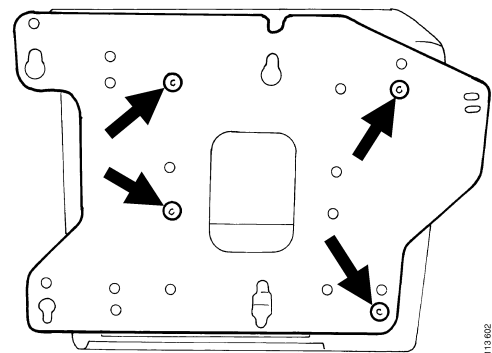

Right hand drive vehicles

- 8 Fit the floor mat and the spacers for the mounting plate screws. Route the cable between the floor mat and the rear panel.

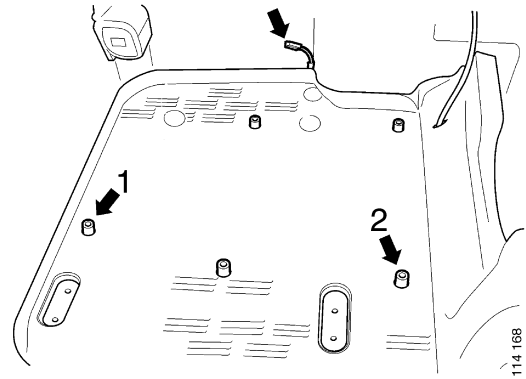

- 1 Spacer, \varnothing 16mm, length 17.5 mm
- 2 Spacer, \varnothing 21mm, length 20.5 mm

- 9 Lift the refrigerator into position and connect connector C287.
- 10 Move the refrigerator longitudinal so that the spacers lock in mounting plate keyholes.
- 11 Lock the mounting plate firmly using a bolt on either side of the refrigerator.

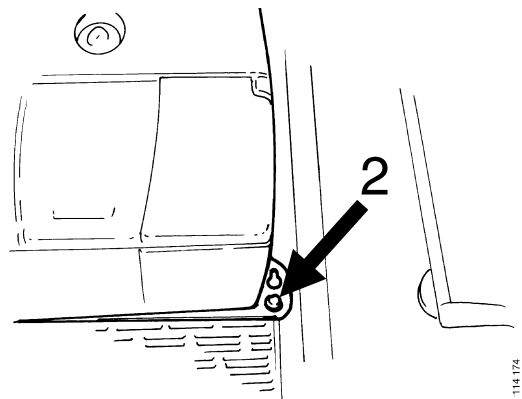
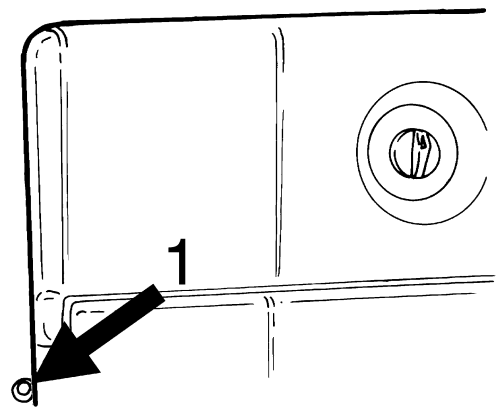

- 1 M6 bolt
- 2 M10 bolt

- 12 Fit the bed support. On LHD vehicles with Eberspächer; renew the air hose, fit a hose bracket and route the hose as shown in the figure.
- 13 Fit the removed panel components.
- 14 Fit fuse 35 in the central electric unit.

IMPORTANT!

Before the refrigerator is switched on it should have been standing in the correct position for at least an hour. This is to ensure the function of the refrigeration compressor lubrication.

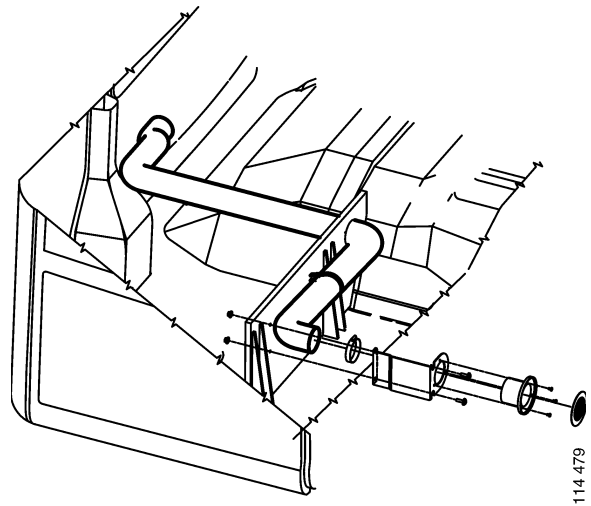

Fitting the refrigerator under the bed, Alt. 1b

1 Remove the front storage box.

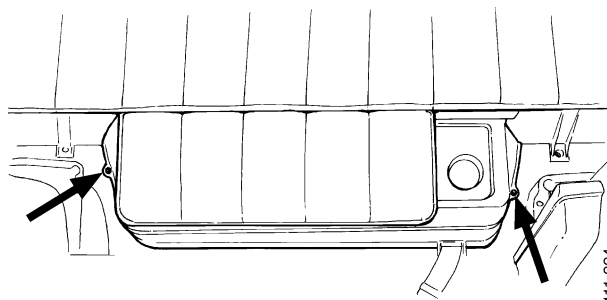

2 Fold back the floor mat and lay down the refrigerator mounting plate together with the spacers. Position the plate so that it is lying level with the spacers and the refrigerator can be slid in place. Mark the positions of the holes.

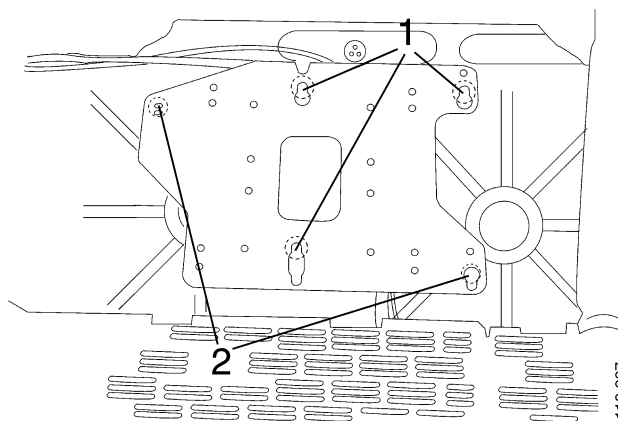

1 Spacer $\text{\O} 27$ mm, length 37.5 mm.

2 Spacer $\text{\O} 20$ mm, length 34 mm and special washer 4 mm.

3 Fold back the floor mat from the cover in the floor and remove the cover.

Note: Detach the connections under the auxiliary heater (if fitted) before removing the cover.

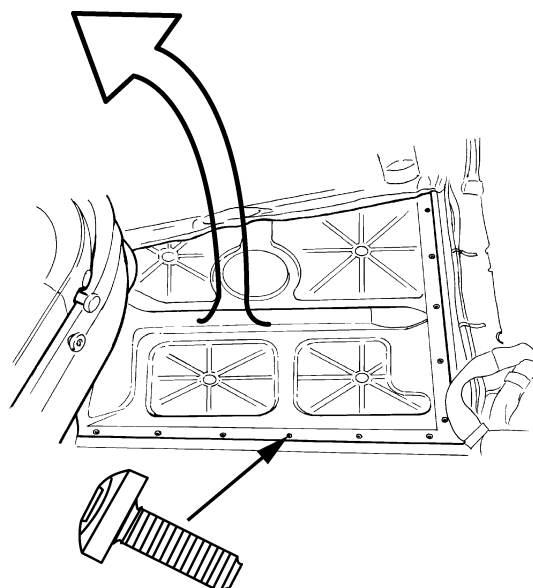

- 4 Drill the attached holes and fit the spacers and blind rivet nuts. Use an M10x50 bolt, finish washer and lock nut for the spacers.

Note: Ensure no damage will be caused underneath the cab floor before drilling the holes.

- 5 Refit the cover in the floor and refit the mat.
- 6 Refit the rear floor mat and make holes for all the spacers.

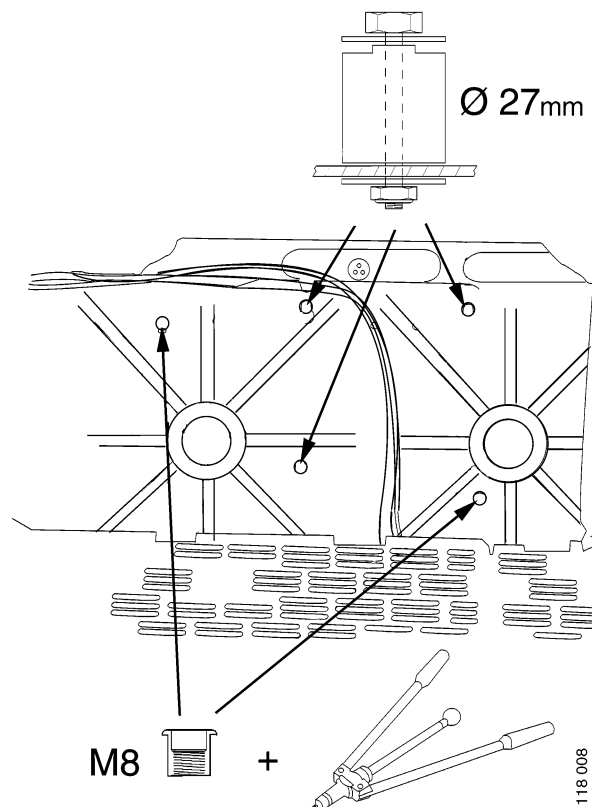
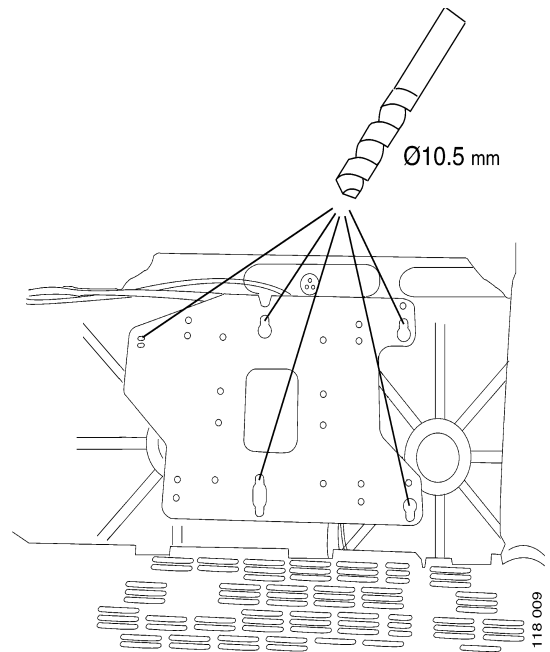

- 7 Position the refrigerator with the rear facing downwards. Fit the mounting plate underneath using four special screws.

Note: The refrigerator must not be turned upside down.

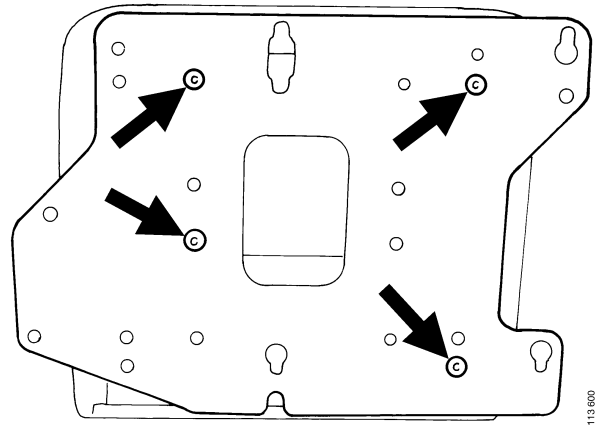

- 8 Make two washers as illustrated. They can be made from washer 297 223. Place the washer over the blind rivet nut.

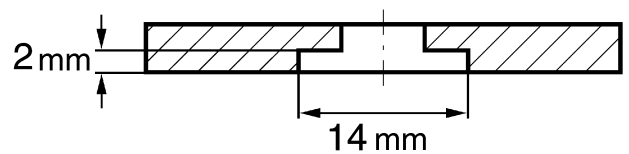

- 9 Lift the refrigerator into position and connect connector C287.
- 10 Move the refrigerator longitudinal so that the spacers lock in mounting plate keyholes.
- 11 Secure the mounting plate with a bolt, washer and spacer on each side of the refrigerator.
- 12 Refit the front storage box.
- 13 Fit fuse 35 in the central electric unit.

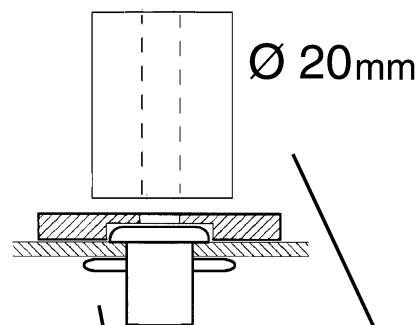
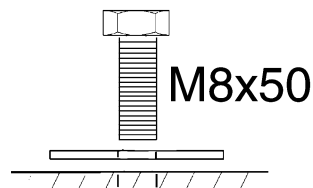
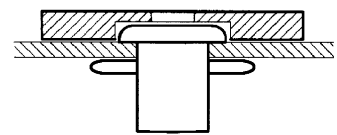

IMPORTANT!

Before the refrigerator is switched on it should have been standing in the correct position for at least an hour. This is to ensure the function of the refrigeration compressor lubrication.

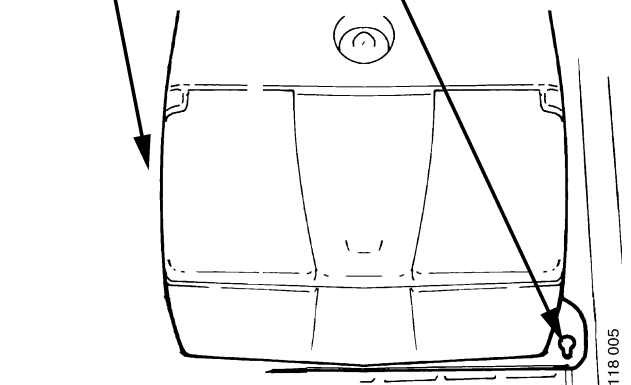

Fitting refrigerator under folding armchair, Alt. 2

- 1 Unscrew the armchair from its bracket on the rear wall, two bolts.
- 2 Fold the floor mat out of the way.

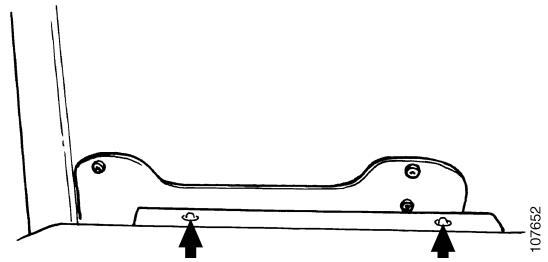

- 3 Remove the insulation over four prepared holes and increase thread to M10.

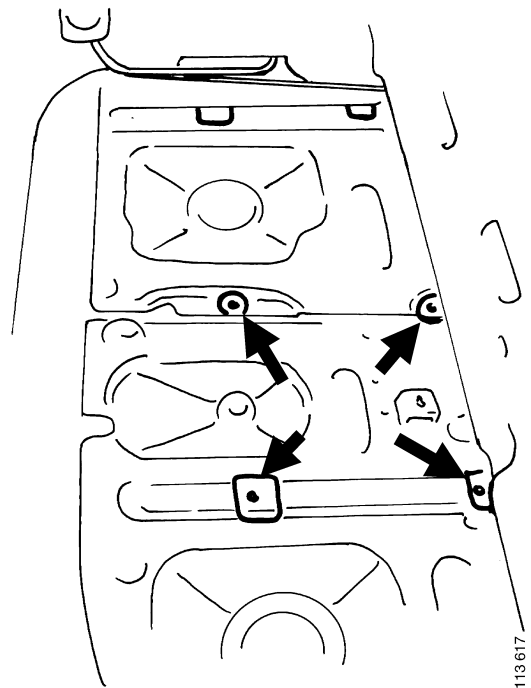

- 4 Fold back the floor mat and mark the location of the holes. The rear hole closest to the engine tunnel is already marked. Use the mounting plate as a template for the other holes.

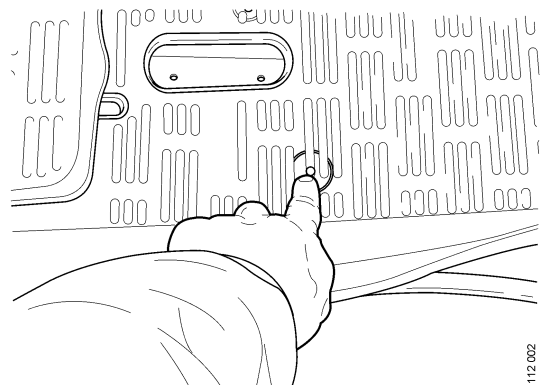

- 5 Make five holes for the spacers as shown in the figure.

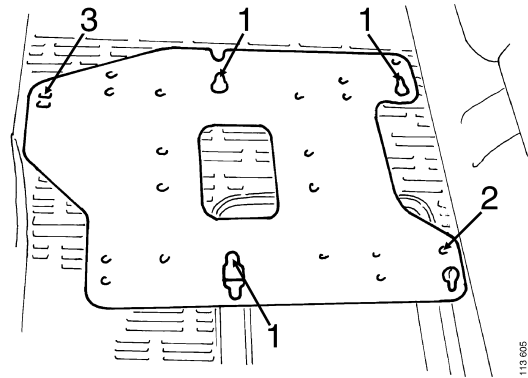

- 1 Spacer, Ø 27 mm, length 37.5 mm
- 2 Spacer, Ø 20 mm, length 34 mm
- 3 Spacer, Ø 16 mm, length 30.5 mm

- 6 Fit three spacers, diameter 27 mm, using 10.5 mm washer and M10x60 bolts. Fold the floor mat back.

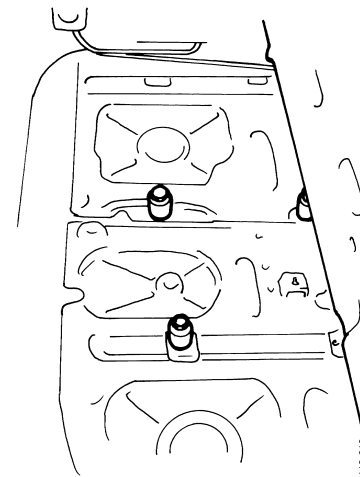

- 7 If the vehicle has a socket for a 230V cab heater then it must be moved. Move the input cable so it goes through the hole in the floor and route it as illustrated.

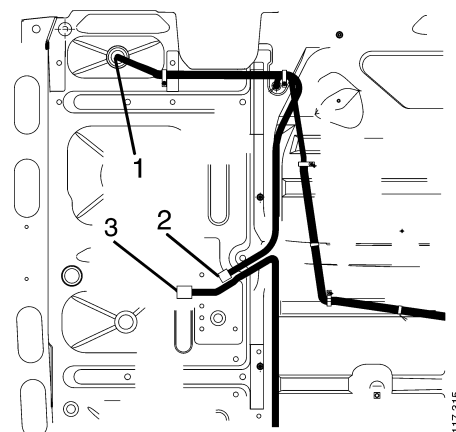

- 1 New hole for cable
- 2 230V socket
- 3 Refrigerator connection

- 8 Make a hole in the mat at the engine tunnel and pull out the refrigerator connection and the input cable for the cab socket. The position of the holes is marked on the mat.

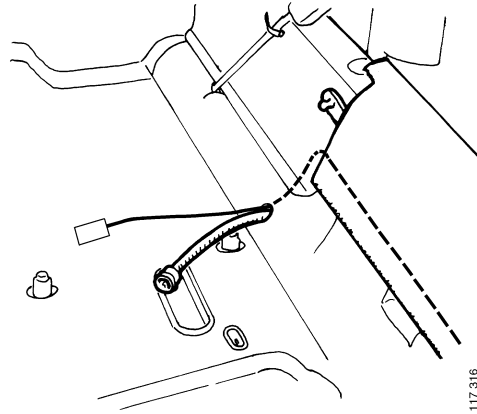

- 9 Remove the passenger seat gas spring bracket with a drill.

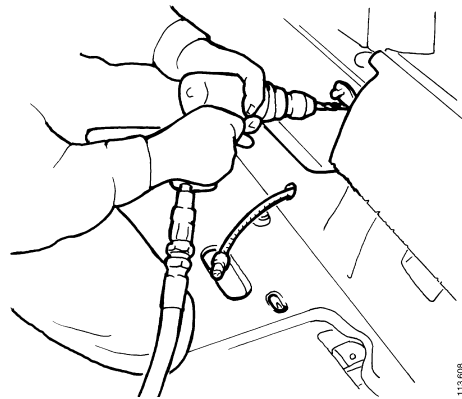

- 10 Fit a new bracket using blind rivets in the engine tunnel and M6x20 bolts in the floor. Fit the gas spring ball joint in the rear hole.

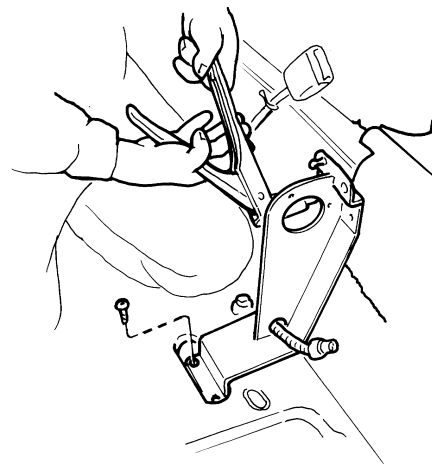

- 11 Fit the 230V socket to the bracket.

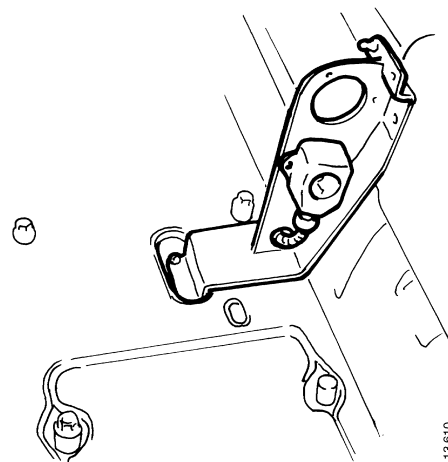

- 12 If the vehicle is fitted with an Eberspächer; fit a hose bracket, cut the air hose and route the hose as illustrated.

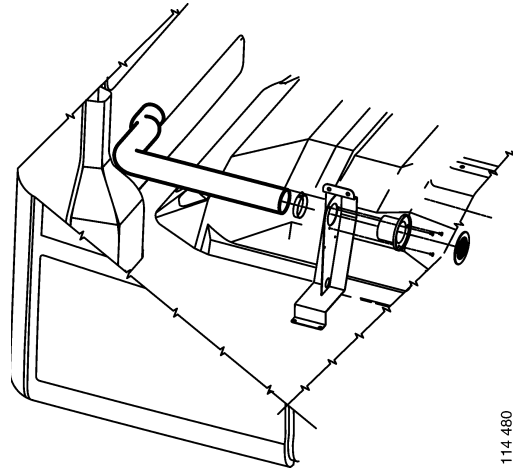

- 13 Position the refrigerator with the rear facing downwards. Fit the mounting plate underneath using four special screws.

Note: The refrigerator must not be turned upside down.

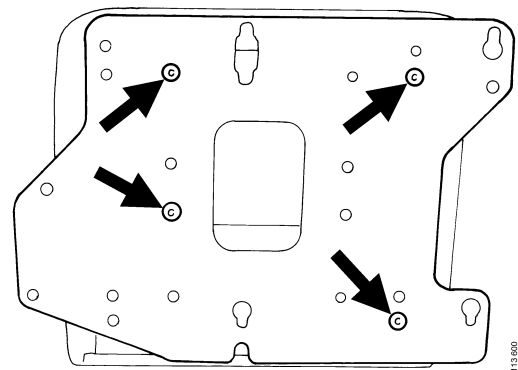

Left hand drive vehicle

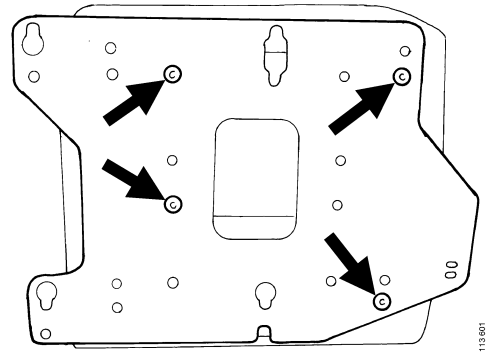

Right hand drive vehicle

- 14 Fit the protection strip on the rear side of the refrigerator using existing bolts.

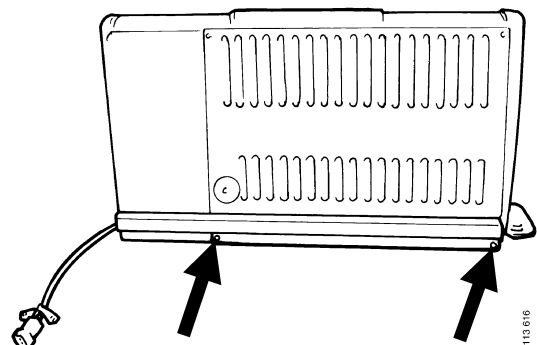

- 15 Fit the floor mat and the spacers for the mounting plate screws.

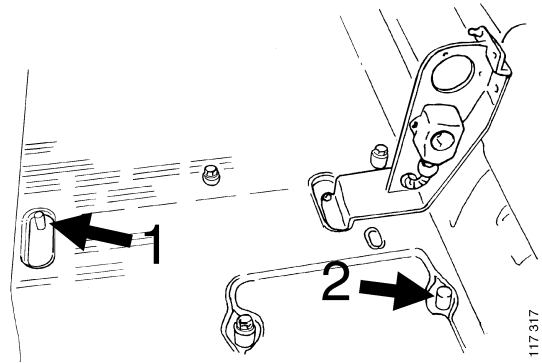

1 Spacer, length 30.5 mm

2 Spacer, length 34 mm

- 16 Lift the refrigerator into position and connect connector C287.
- 17 Move the refrigerator longitudinal so that the spacers lock in mounting plate keyholes.
- 18 Lock the mounting plate firmly using a bolt on either side of the refrigerator.

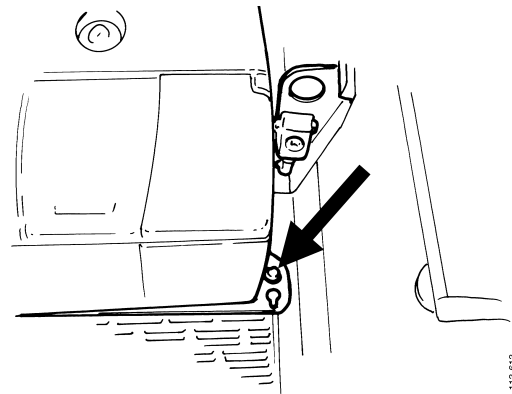
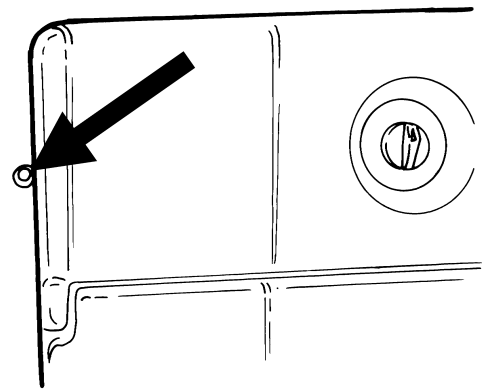

3 M6 bolt

4 M10 bolt

- 19 Cut 16 cm off the thin rubber mat as shown in the figure and fit it.

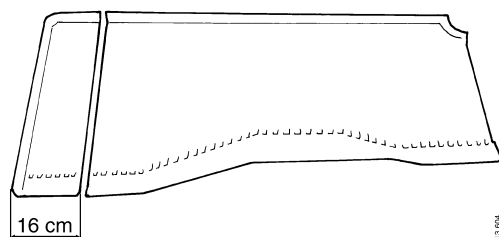

- 20 Rivet the support to the underside of the seat using two special blind rivets.
- 21 Fit the cover underneath the seat and fit the seat.

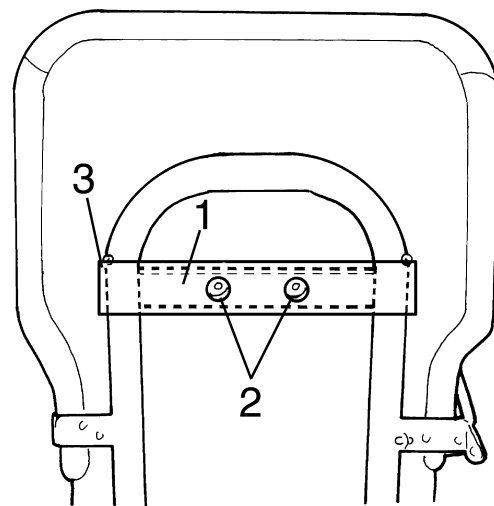

- 1 Support
- 2 Blind rivet
- 3 Cover

- 22 Fit the kick strip and panel components.
- 23 Fit fuse 35 in the central electric unit.

IMPORTANT!

Before the refrigerator is switched on it should have been standing in the correct position for at least an hour. This is to ensure the function of the refrigeration compressor lubrication.

Fitting refrigerator in extendable rear centre storage box, Alt. 3

- 1 Make a hole $\varnothing 30$ mm in the rear centre panel for the electrical connection of the refrigerator. Applies to vehicles built before November 1999.

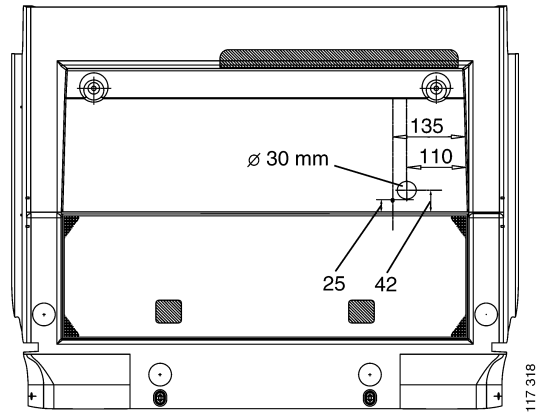

- 2 Fasten the electric cable with a rubber-lined clamp at the white marking on the cable. Use screw and nut, M 5x16 mm.
- 3 Connect the electric wiring and refit the centre panel.

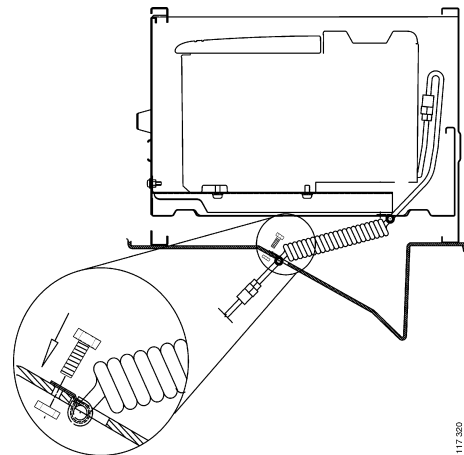

- 4 Make two holes, $\varnothing 50$ mm and $\varnothing 5$ mm, in the bottom of the storage box. Applies to vehicles built before November 1999.

Note: Discard the box insert.

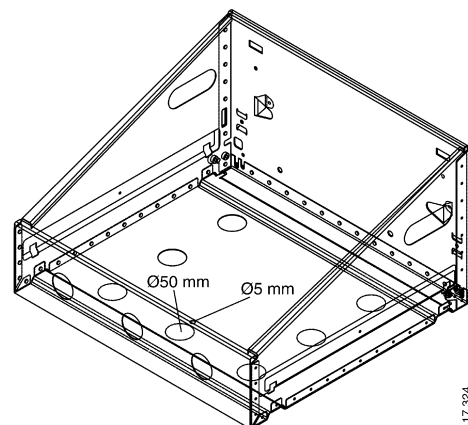

- 5 Make two holes in the front of the storage box.

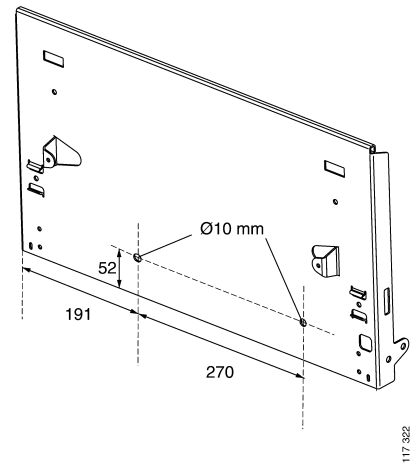

- 6 Make two vent holes in the storage box lid.
- 7 Refit the storage box.

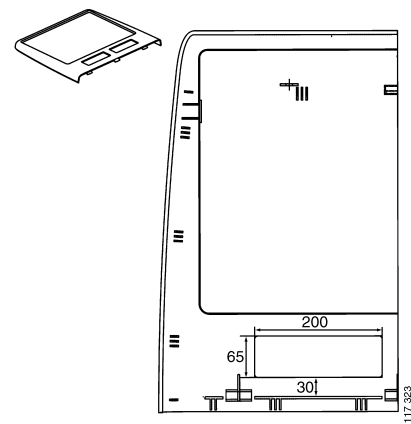

- 8 Fasten the electric cable to the bottom of the storage box with a rubber-lined clamp at the white marking on the cable. Use screw and nut, M 5x16 mm.

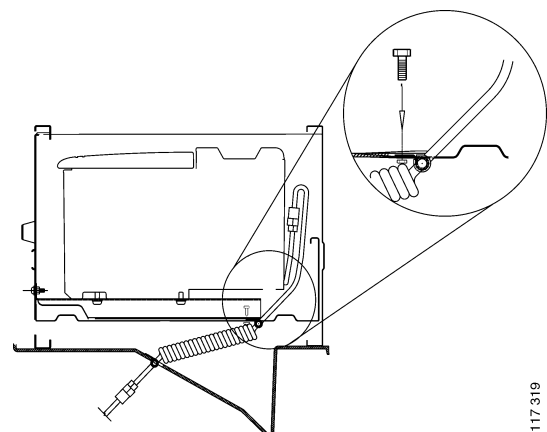

- 9 Fit the brackets to the bottom of the refrigerator. Cut the anti-vibration tape and affix it to the brackets.

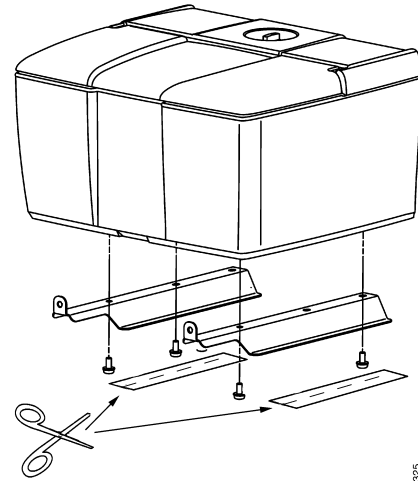

117 325

- 10 Lift the refrigerator into the box and plug together connectors C287/C476. Tighten the refrigerator brackets with two bolts at the front.
- 11 Fit the storage box side panels and lid.
- 12 Fit fuse 35 in the central electric unit.

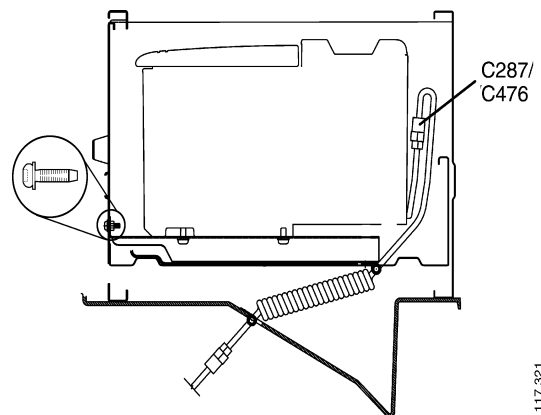

117 321

IMPORTANT!

Before the refrigerator is switched on it should have been standing in the correct position for at least an hour. This is to ensure the function of the refrigeration compressor lubrication.

Fitting refrigerator behind driver's seat, Alt. 4

- 1 Remove the rubber mat and wooden board behind the driver's seat.

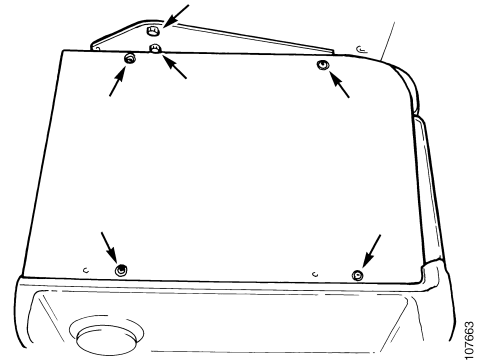

- 2 Fit the new mounting plate.

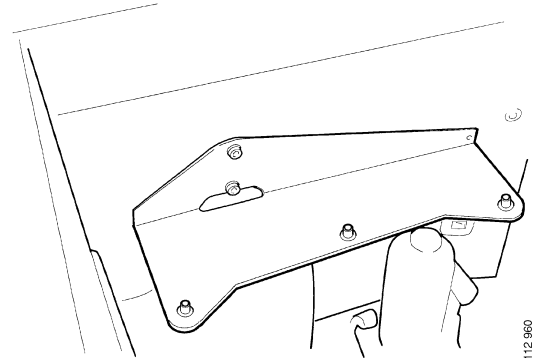

- 3 Refit the wooden board and mark out the new attachment holes, $\text{Ø} 10.5 \text{ mm}$.

- 4 Make holes in the rubber mat for the spacers.

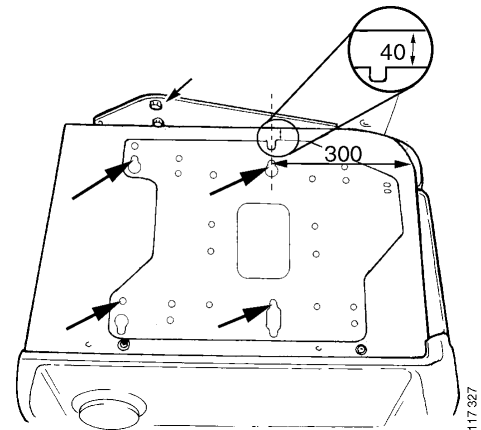

- 5 Fit the three spacers, $\text{Ø} 27 \text{ mm}$ and length 23 mm, as illustrated. Use M10x55 bolts, finish washers and lock nuts.

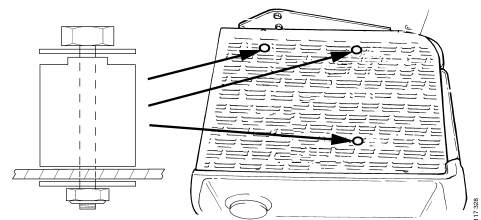

- 6 Position the refrigerator with the rear facing downwards. Fit the mounting plate underneath using four special screws.

Note: The refrigerator must not be turned upside down.

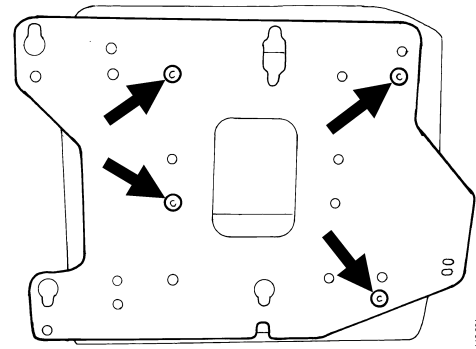

Left hand drive vehicle

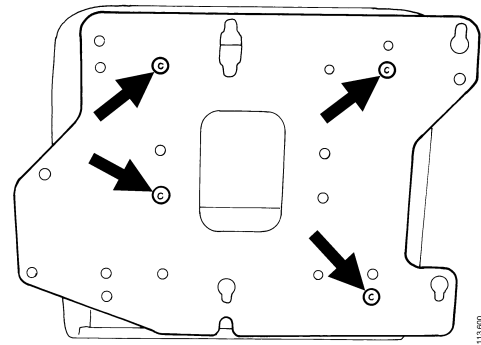

Right hand drive vehicle

- 7 Slide the refrigerator in place and fit the last spacer, Ø 27 mm and length 23 mm, upside down.

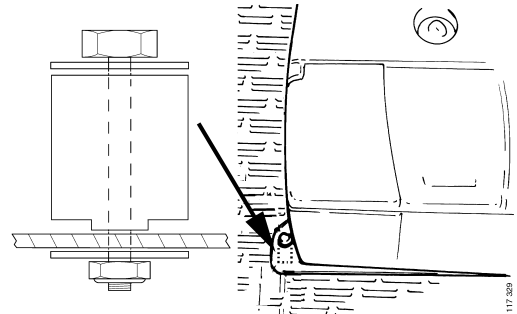

- 8 Tighten the refrigerator with M10x55, finish washer and lock nut.
9 Connect the switch to the refrigerator.

IMPORTANT!

Before the refrigerator is switched on it should have been standing in the correct position for at least an hour. This is to ensure the function of the refrigeration compressor lubrication.

