

SCANIA

18:01-10

Issue 2 en

Windscreen

Upper windscreen on Front Line

Work description

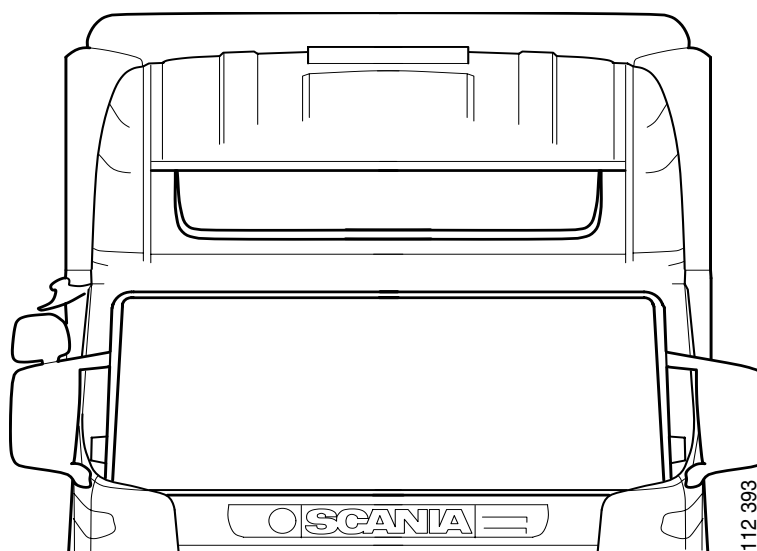

Contents

Windscreen	Removal.....	3
	Installation	4
	Sealing a leaking windscreen	8
Upper windscreen on Front Line	Removal.....	9
	Installation	11

Windscreen

At least two people are required for this job. The windscreen is large and heavy. Use a high workbench to stand on in front of the cab. This will make the job easier.

Removal

- 1 Remove the external sun shade.
- 2 P and R cabs: Fold out the corners of the cab and fold down the front hatch. Remove the recirculation guards.

T cab: Open the engine bonnet and remove the cab front extensions.

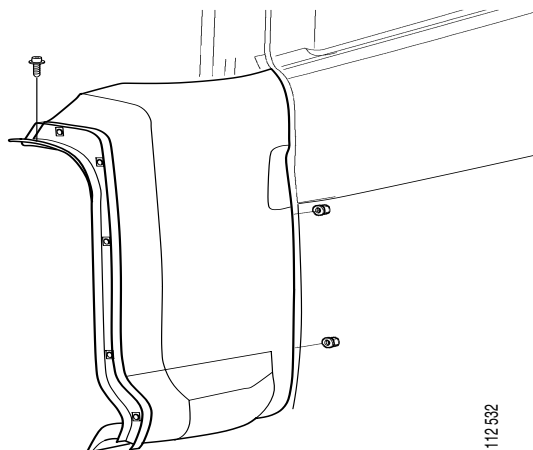

Cab front extensions on the T cab.

- 3 Disconnect and fold down the windscreen wiper arms.
- 4 Two people: Position yourselves so that you are ready to help disconnect and remove the windscreen from the outside.
- 5 One person: Sit in the seat and press out the windscreen from the inside with your feet. Start in one of the upper corners.
- 6 Remove the rubber moulding. Check that it is complete and can be re-used.

Installation

- 1 Lay down the windscreen with the outside down.
- 2 Install the moulding around the windscreen. Be careful to position the corners of the moulding precisely on the corners of the windscreen. Check that the moulding is fitted correctly in the corners.

Note: Position the moulding so that the long lip is on the inside of the windscreen and along its lower edge!

- 3 Apply sealant part no. 336 864, on the inside between the glass and the moulding. *See illustration.*

Note: Use a minimum of 70 ml and a maximum of 90 ml of sealant per vehicle!

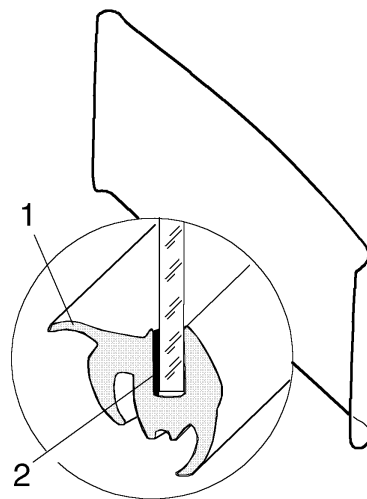

- 1 Lip on the inside of the windscreen and along its lower edge.
- 2 Sealant

- 4 Install a cord, approximately 10 metres long, in the moulding as follows:

Start in the middle of one the short sides of the windscreen and continue round its lower edge. Allow approximately 40 cm of the cord to hang outside the moulding.

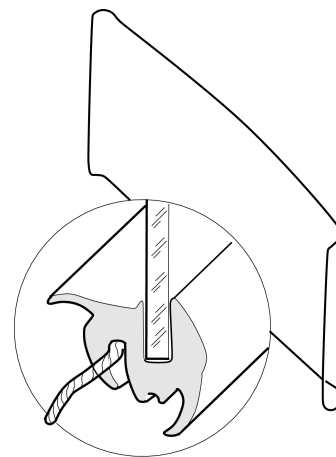

Install the cord around the entire windscreen. Double it up along the lower edge and up to the middle of the next short side, 1. Allow approximately 40 cm of the cord to remain hanging along the windscreen.

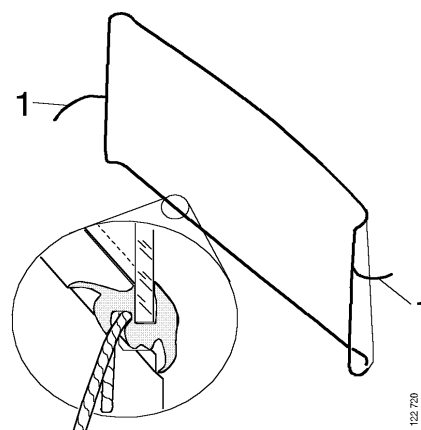

- 5 Apply a thick rust-proofing grease, e.g. Dinitrol 4411, around the frame where the windscreen will be positioned. The grease facilitates installation of the windscreen and has rust-proofing characteristics.

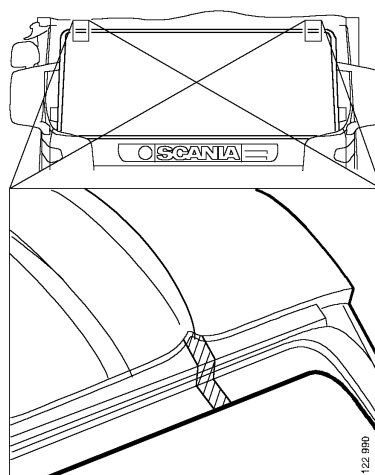

- 6 Apply sealant part no. 336 864, at both the joints which are exposed where the roof mouldings end.

- 7 Apply a bead of sealant, part no. 336 864, under the panel, approximately 3 mm from the upper edge. Smooth out the sealant around the front and rear edges so that it fills up any unevenness between the moulding and the frame.

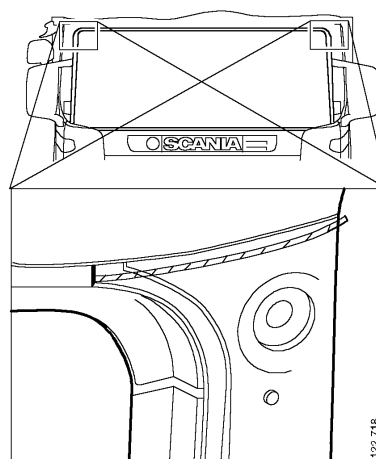

- 8 Also apply sealant, part no. 336 864, between the lower edge of the panel on the front door pillar and the marking on the plate. Do the same on both sides.

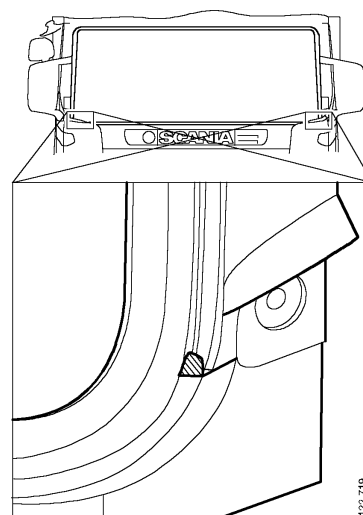

Note: Procedures 9 and 10 require three people!

- 9 Centre the windscreen sideways between the cab pillars, 1 Make sure that the free ends of the cord hang inside the vehicle.

Note: Make sure that windscreen is positioned at the lower edge first, before it is pressed into place at the upper edge!

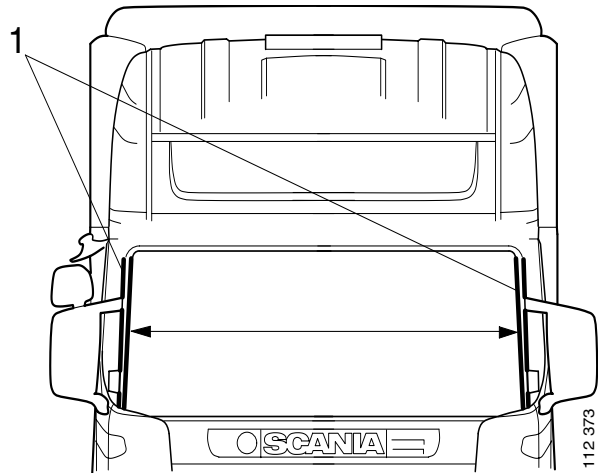

- 10 Press the windscreen against the windscreen frame. Install the moulding by pulling one end of the cord from the inside. Start with the end of the cord which was placed in the moulding last. Pull the cord along the lower edge and up to the middle of the next short side. Tap the windscreen with a soft rubber mallet from the outside while removing the cord.

Now pull the other end of the cord to the middle of the opposite short side. Tap the windscreen carefully with a soft rubber mallet from the outside while removing the cord. Check that the windscreen is correctly positioned in the lower edge before the cord is finally removed from the upper edge.

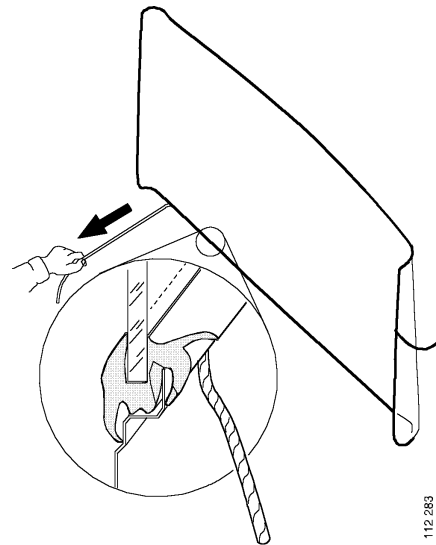

- 11 Use a hook-ended tool to draw the moulding into place on the outside of the cab pillars. Then tap with a soft rubber mallet around the windscreen so that the moulding and windscreen are located in their final position on the windscreen frame.

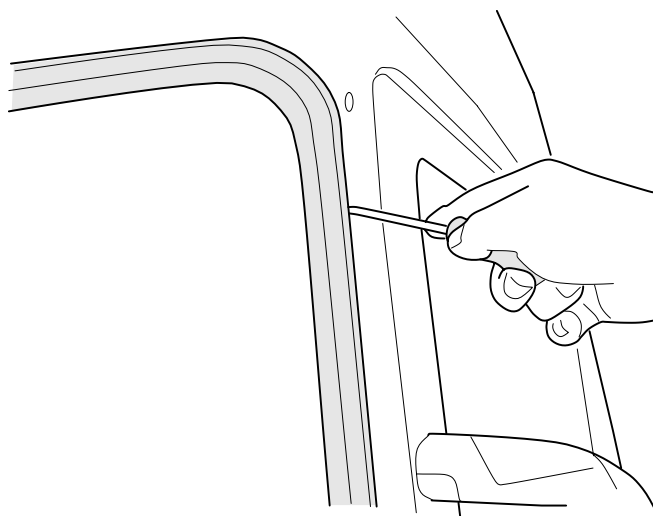

112 489

TIP! A screwdriver can be used as a hook-ended tool. But the tip must be bent slightly more than 90 degrees and any sharp edges ground off!

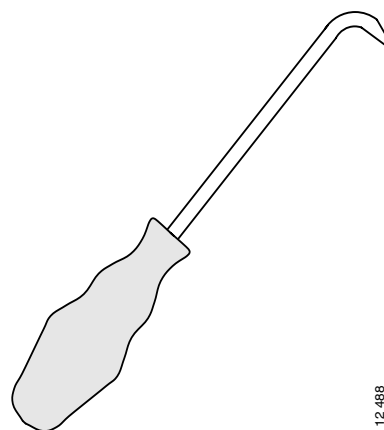

112 488

Note: Finally check carefully that the moulding is correctly positioned around the entire edge of the windscreen frame!

Sealing a leaking windscreen

There are two types of leaks around a windscreen.

- 1 Leaks between the windscreen and the moulding. In this case you can see water drops and moisture on the upper side of the windscreen moulding from inside the cab.

Apply sealant, 1, part no. 336 864, between the glass and the moulding on the outside of the windscreen.

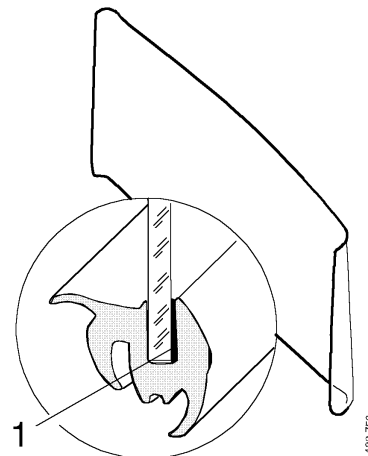

- 2 Leaks between the windscreen moulding and the windscreen frame. In this case water occurs mainly under the windscreen moulding and on the defroster beam.

Supplement earlier sealing, See steps 6, 7 and 8 in the section Installation.

With recurrent leaks, a suitable object, e.g. a plastic pipe, can be positioned on the outside between the windscreen frame and moulding so that any water collecting there can be drained off.

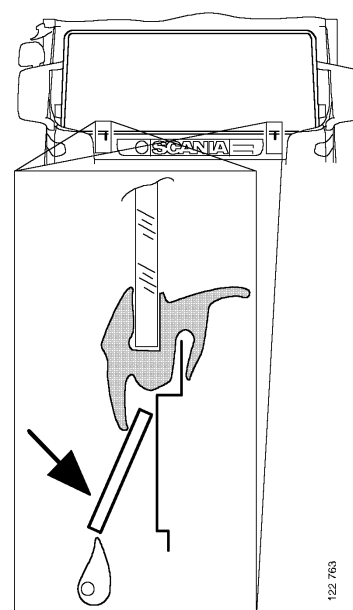

Upper windscreen on Front Line

Removal

We recommend that the windscreen is cut out with a pneumatic cut-out tool. The windscreen can also be cut out with a cold knife or cheese wire. In such cases, a large amount of the interior must be removed. There is also an increased risk of damage to paintwork. The latter methods are not described here.

- 1 Remove the roof plate lighting.

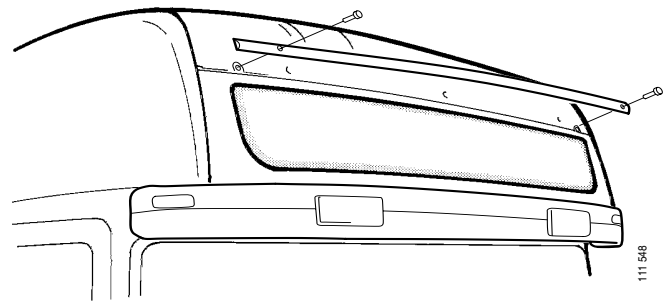

- 2 Cut away the adhesive in the gap around the windscreen with a universal knife. Access with the pneumatic cut-out tool will then be easier.

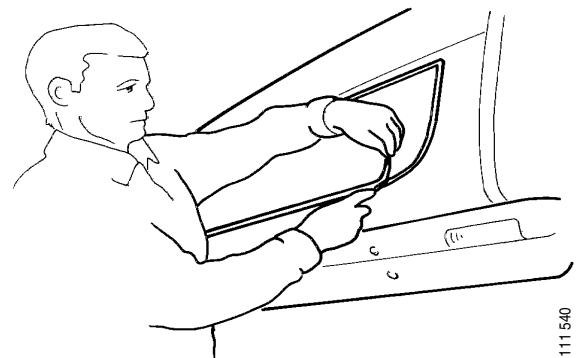

- 3 Use a pneumatic cut-out tool to cut out the windscreen. Use a U-shaped knife blade.

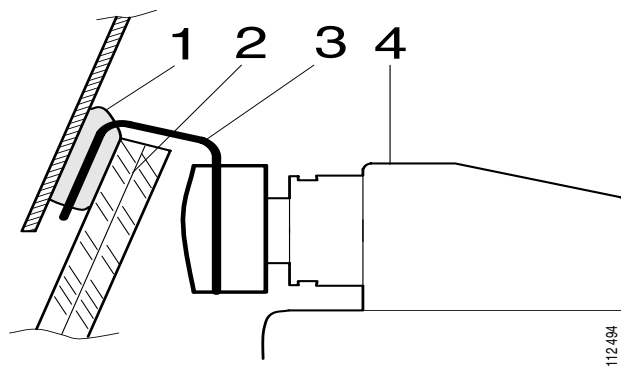

- 1 *Adhesive*
- 2 *Glass*
- 3 *U-shaped knife blade*
- 4 *Pneumatic cut-out tool*

- 4 Clean the knife blade.
- 5 Start cutting at the top edge. This is the easiest point to insert the knife blade, and where there is least risk of the blade getting in between the glass layers.

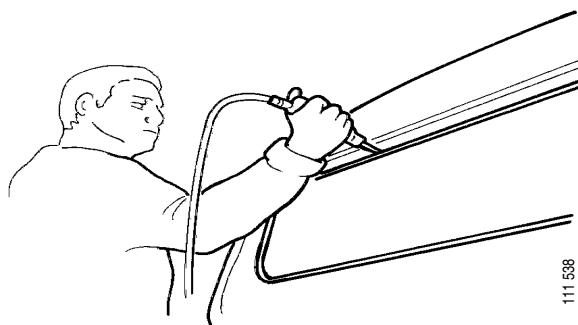

Installation

- 1 Clean a universal knife.
- 2 Cut away any adhesive residue from the windscreen frame. Leave a 1 mm thick layer as a base for the new adhesive. Vacuum around the edges so that any loose adhesive residue is removed.
- 3 If using glass lifters, install them on the new windscreen.
- 4 Position the new windscreen in the centre of the opening.

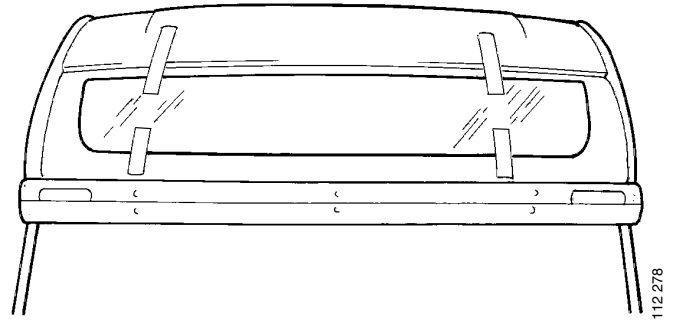

IMPORTANT! The windscreen must be centred correctly to ensure that the gap around the windscreen is sufficient!

Tape the windscreen into place with four pieces of tape. Cut the pieces of tape. They will be used as alignment markers.

- 5 Clean the edge of the windscreen with primer 487 619. Wait five minutes.
- 6 Apply adhesive 487 617 around the edge of the windscreen. The adhesive does not contain any isocyanates and does not give off a strong odour.

There must not be any seams in the adhesive. Install the windscreen within 15 minutes.

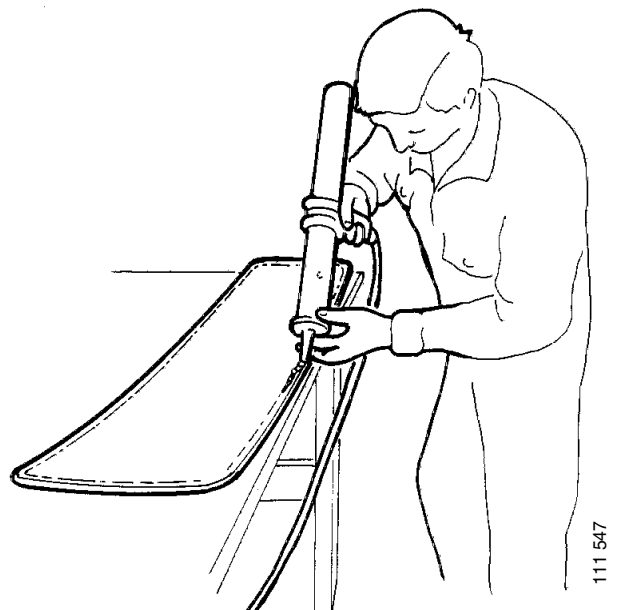

- 7 Position the windscreen in the correct position so that the tape pieces are aligned. Support tape, 1. Remove the glass lifters if applicable.

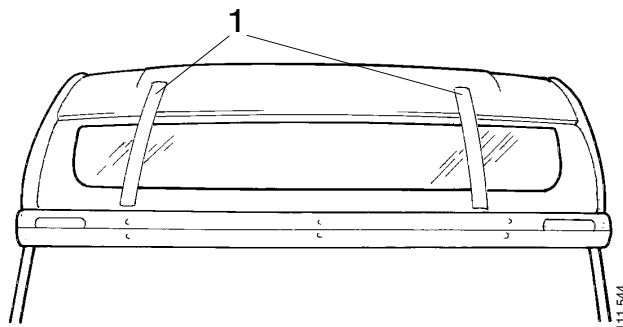

- 8 Apply masking tape around the windscreen frame and fill the gap with adhesive.

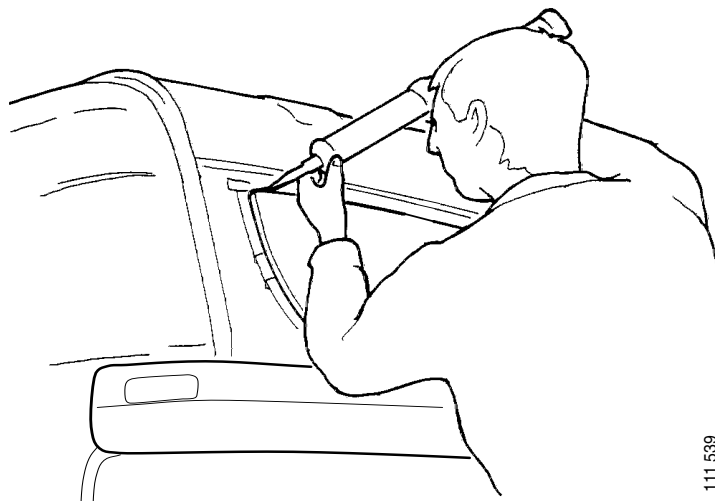

- 9 Even out the beads of adhesive with a wooden putty knife. The wooden putty knife must have been well soaked in soapy water.
- 10 Remove the masking tape.
- 11 Reinstall the roof plate lighting.