

SCANIA

18:01-56

Issue 01 en

Floor

Work description

Buses CN94, CL94

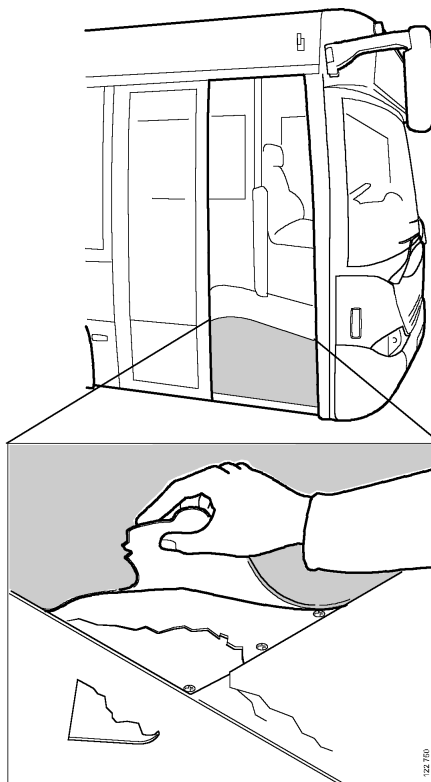

Contents

General	3
Work description	5
Location of floorboard screws	10

General

Scania has two different floorboards specified as parts. Both types are manufactured from plywood.

It is necessary to saw the board to the required shape.

There are two different thicknesses of floorboards, 18 and 2x12 mm. The floorboards are treated with primer by the supplier, as a protection against moisture.

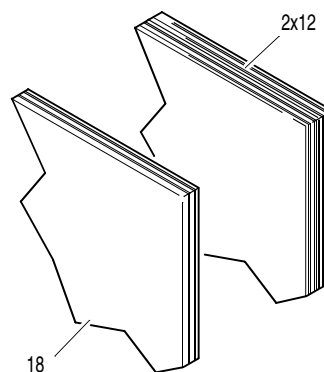

12.576

After a floorboard has been sawn, the floorboard should be pre-treated. All sawn surfaces on the board, apart from the surface which the mat will be glued to, should be treated with primer.

It is acceptable to joint a part of a damaged floorboard, provided that there is a support beneath the joint which provides a flange of approximately 20-30 mm for the floorboard to rest on. This is to ensure that there is enough material beneath the board to fasten to.

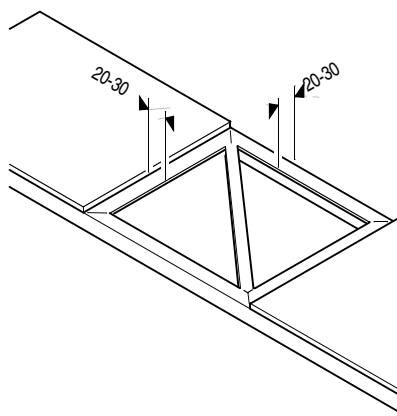

12.577

IMPORTANT! Make sure that you seal around the floorboard so that no moisture can penetrate. The floor mat is glued at the factory with a water-based adhesive. If moisture penetrates, the adhesive dissolves and the mat becomes loose.

All surfaces between the frame or floor support and floorboard and other places where moisture can penetrate, should be covered with sealing compound.

The floorboard is screwed down with self-tapping screws according to section “Location of floorboard screws”. The screw spacing varies depending on where the floorboard is located in the vehicle.

The screws should penetrate and properly fasten the floorboard to the material it is being screwed on to.

Work description

Specifications

Substance	Property	Comments
Primer	Reduces moisture penetration.	Beckers Vindy aa136 is used in production at Scania.
Sealing compound	Moisture proofing, elastic, good adhesion.	Simson ISR 70-04 is used in production at Scania.
Putty	Rapid hardening fine putty.	Ardex Ardurapid 5 is used in production at Scania.
Adhesive	Water-based contact adhesive.	Bostik 31 is used in production at Scania.
Corrosion inhibitor	Viscous underseal.	Dinitrol Penetrant and Dinitrol Sealant are used in production at Scania.

- 1 Note how the frame and floor support are positioned beneath the damaged floorboard to see whether it is necessary to replace the whole board or whether it can be jointed.

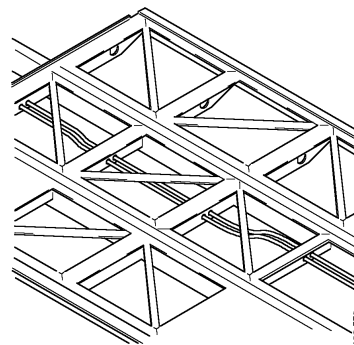

- 2 Cut the mat and remove the floorboard which has to be replaced.
- 3 Sketch the floor board onto the new floorboard and saw it out.

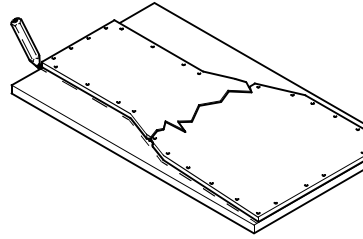

122 F80

IMPORTANT! Do not treat the surface which the mat will be glued to.

- 4 Treat all sawn edges with primer, apart from the surface which the mat will be glued to.

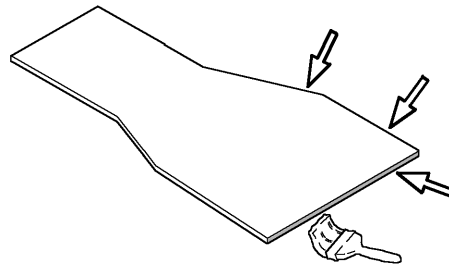

122 F80

- 5 Transfer any covers to the new floorboard.
- 6 Remove old sealing compound from the frame and floor support.

- 7 Apply new sealing compound in a bead approximately 10 mm wide, approximately 7 mm from the outer edges of the frame or floor support, and on other places where there is a risk that moisture may penetrate and damage mats and floorboards.

Note: Fit the floorboard within 5-10 minutes, otherwise a film may be formed on the sealing compound and the adhesion to the floorboard will be reduced.

IMPORTANT! Make sure that you seal it so that no moisture can penetrate. The floor mat is glued at the factory with a water-based adhesive. If moisture penetrates, the adhesive dissolves and the mat becomes loose.

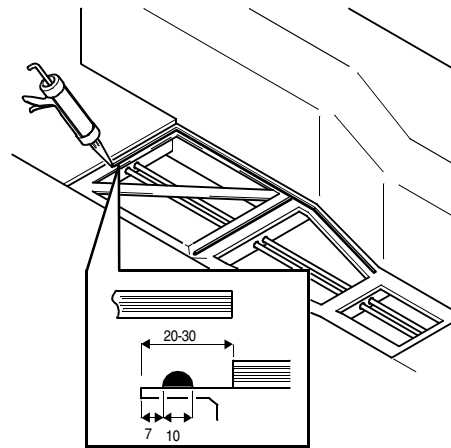

122 591

- 8 Screw down the floorboard according to section “Location of floorboard screws”. The screw spacing varies depending on where the floorboard is located in the vehicle.

The screws should penetrate and properly fasten the floorboard to the material it is being screwed on to.

- 9 Countersink the screws that that they do not stick up above the edge of the floorboard. In floorboards 2x12 mm thick, the screw is countersunk through the first 12 mm.

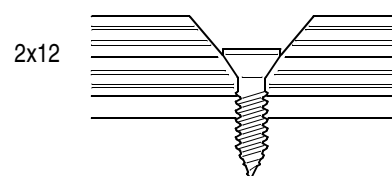
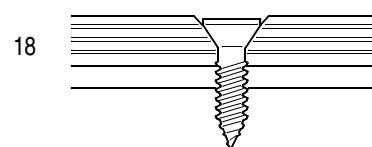

122 592

- 10 Cut the screws on the underside so that they do not protrude.

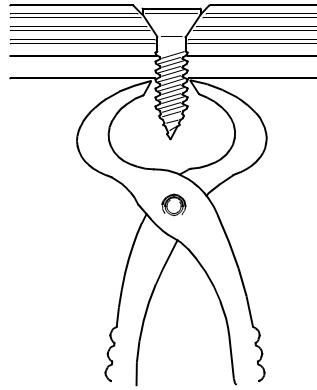

122583

- 11 Fill joints, screw holes and other uneven areas with putty. Allow the putty to dry for a few minutes and then scrape away any excess putty.

Note: It is not necessary to grind down the putty.

- 12 Clean the floorboard of any dirt and putty residues so that the surface is smooth.
- 13 Cut out a floor mat which fits the area to be repaired.
- 14 Apply a smooth layer of contact adhesive with a roller, for example, to the floorboard and mat.

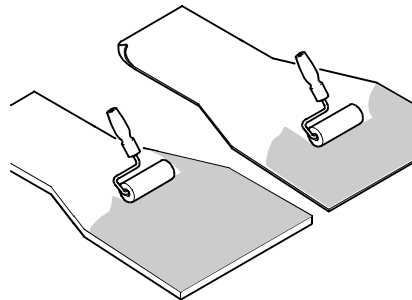

122584

- 15 Place the mat on the floorboard when the adhesive has dried enough so that there is no adhesion on contact.
- 16 Smooth out the mat so that the adhesive is properly affixed and any air bubbles disappear. If necessary, trim the edges of the mat.

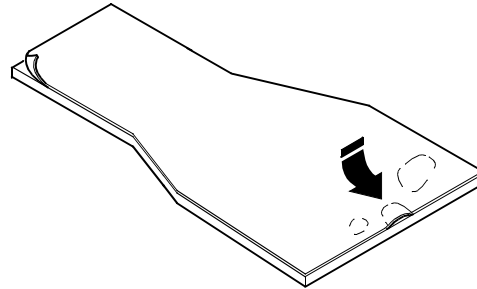

122.585

- 17 Weld the edges of the mat, trim off the remaining welding rod and level the joints.

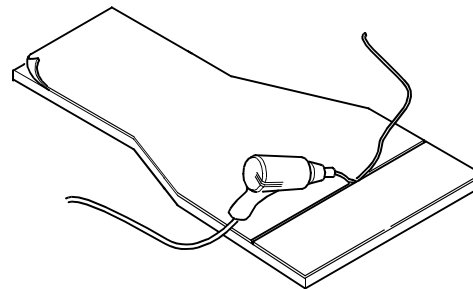

122.586

- 18 Check the anti-corrosive protection on the frame and floor support. Supplement with more anti-corrosion protection where necessary.

Location of floorboard screws

General

The screws should have a specific spacing between them depending on where the floorboard is located in the vehicle.

The screws should penetrate and properly fasten the floorboard to the material it is being screwed on to.

Check the location of the old floorboard in the vehicle and the positioning of the screws in the floorboard.

Front floor

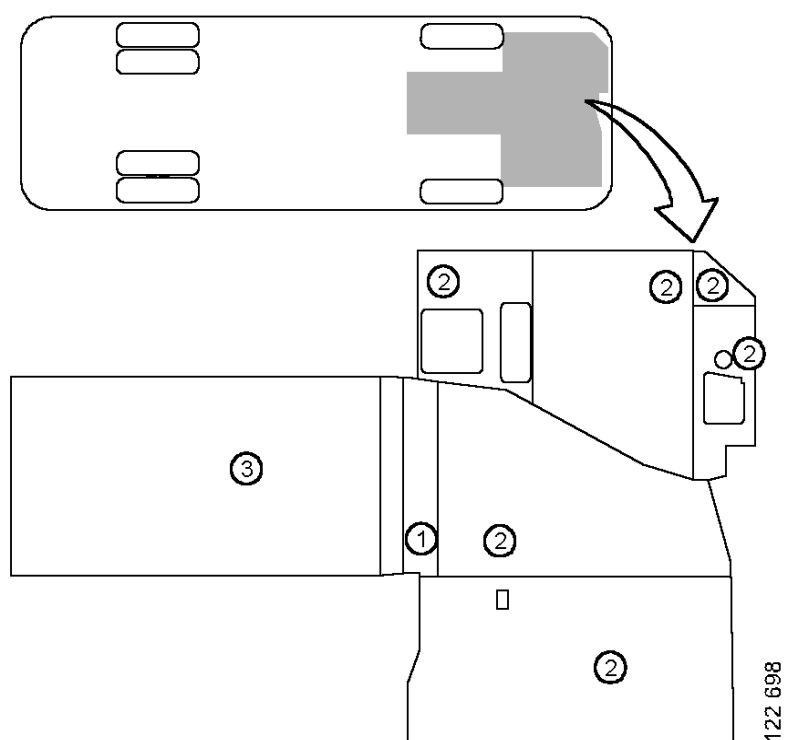

- 1 The spacing between the screws should be 100 mm.
- 2 The spacing between the screws should be 200 mm.
- 3 The spacing between the screws should be 400 mm.

Location of screws in vehicles with single front door

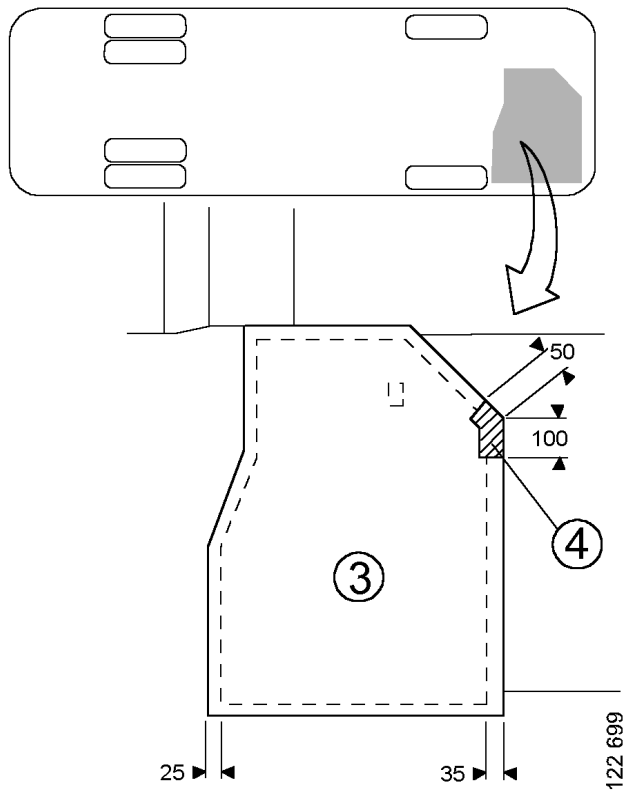

- 3 The spacing between the screws should be 400 mm.*
- 4 No screws should be placed within the marked area.*

Central floor

Location of screws on CN94UB without a wheelchair ramp

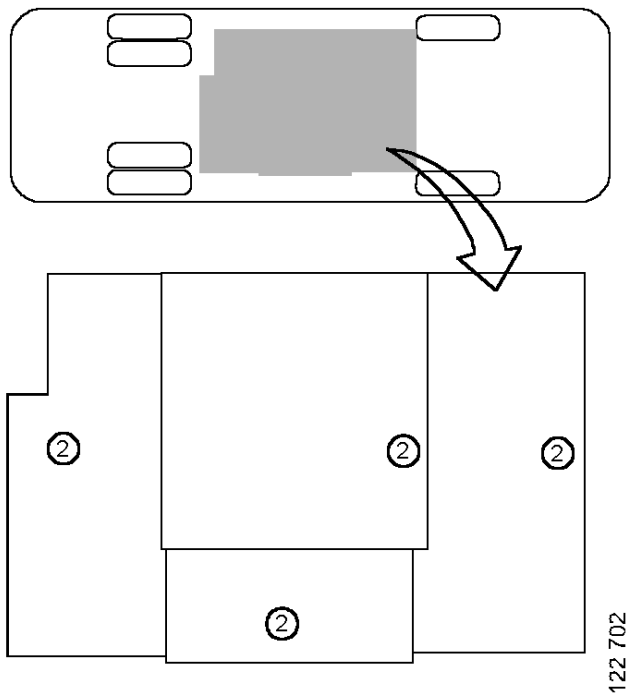

2 The spacing between the screws should be 200 mm.

Location of screws on CN94UB with an electrical wheelchair ramp

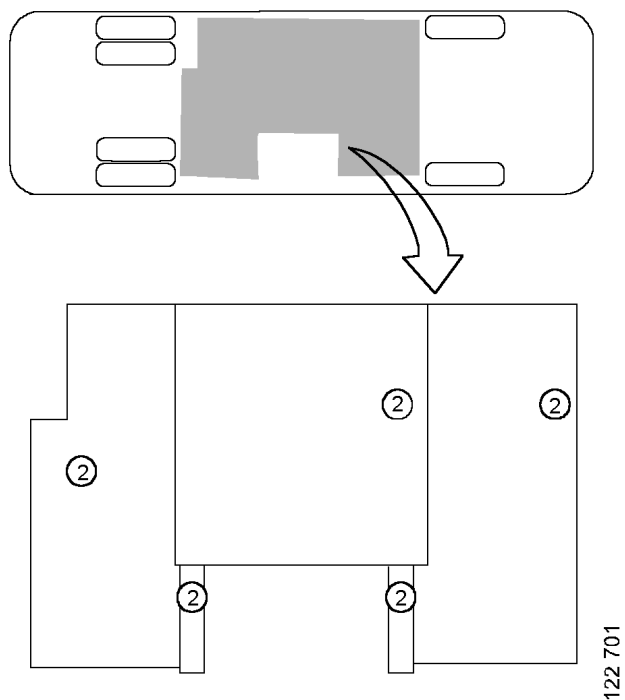

2 The spacing between the screws should be 200 mm.

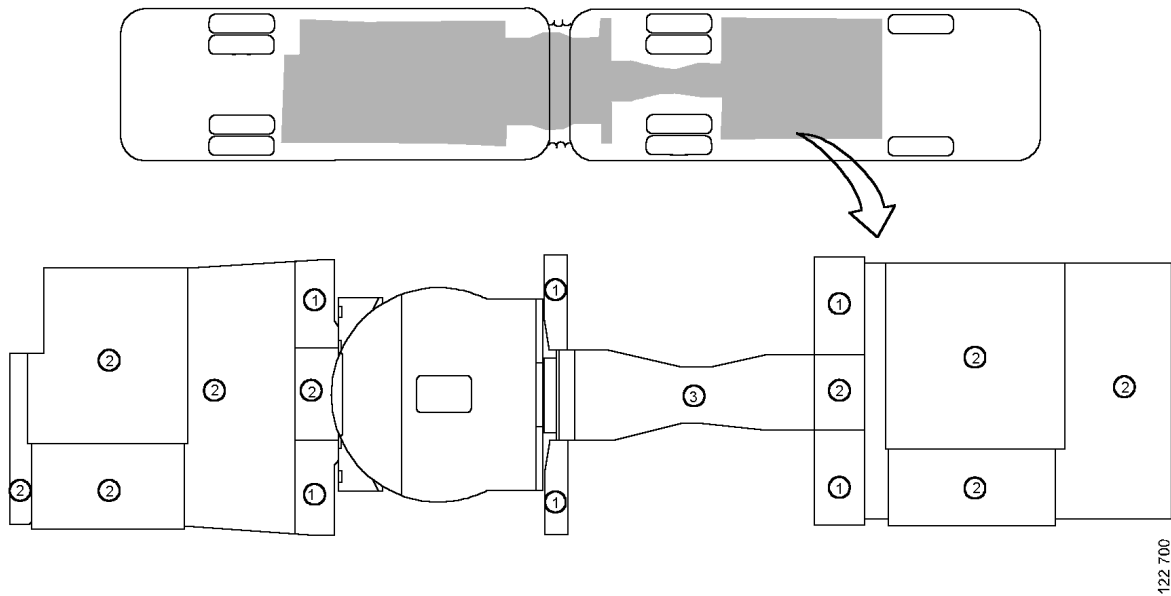
Location of screws on CN94UA articulated bus

- 1 The spacing between the screws should be 100 mm.*
- 2 The spacing between the screws should be 200 mm.*
- 3 The spacing between the screws should be 400 mm.*

Rear floor

Location of screws on CN94 with double rear doors without a standing room area between the rear axle and rear seats

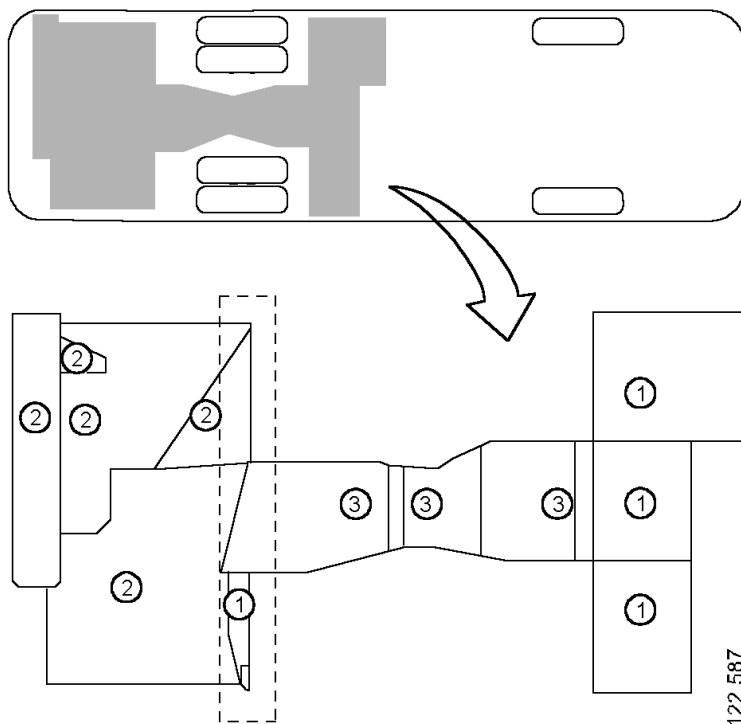

1 The spacing between the screws should be 100 mm.

2 The spacing between the screws should be 200 mm.

3 The spacing between the screws should be 400 mm.

Within the marked area the spacing between the screws should be 100 mm.

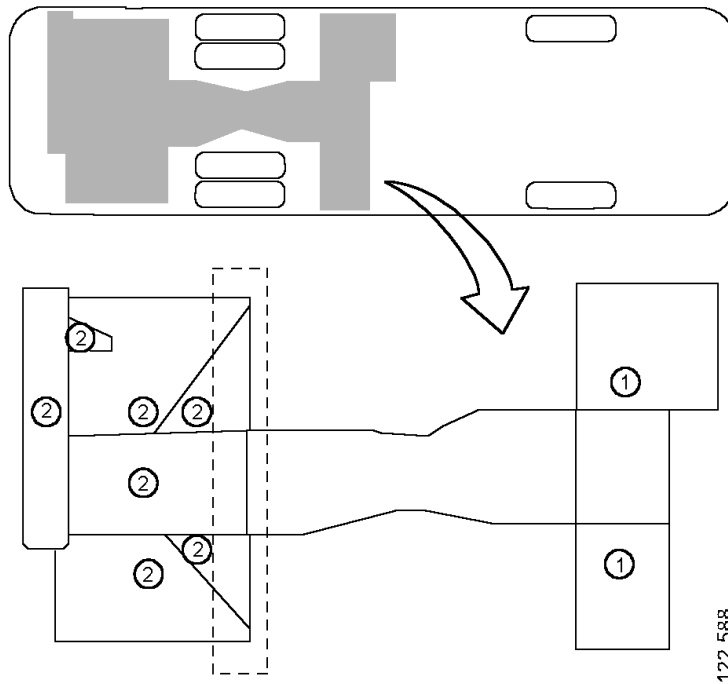
Location of screws on CN94 without a door behind the rear axle

1 The spacing between the screws should be 100 mm.

2 The spacing between the screws should be 200 mm.

Within the marked area the spacing between the screws should be 100 mm.

Location of screws on CN94 with a standing room area between the rear axle and rear seats

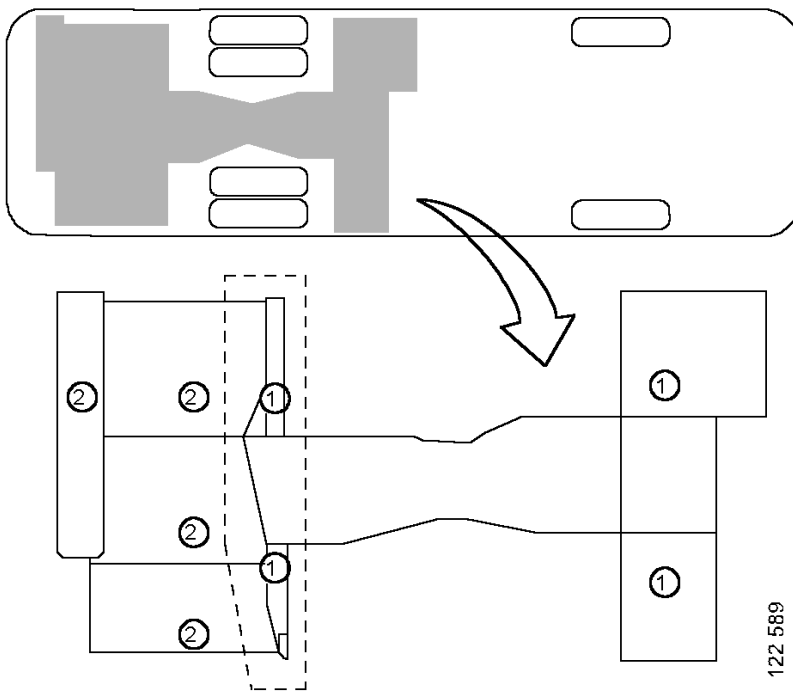

1 The spacing between the screws should be 100 mm.

2 The spacing between the screws should be 200 mm.

Within the marked area the spacing between the screws should be 100 mm.

Location of screws on CN94 with a single door behind the rear axle

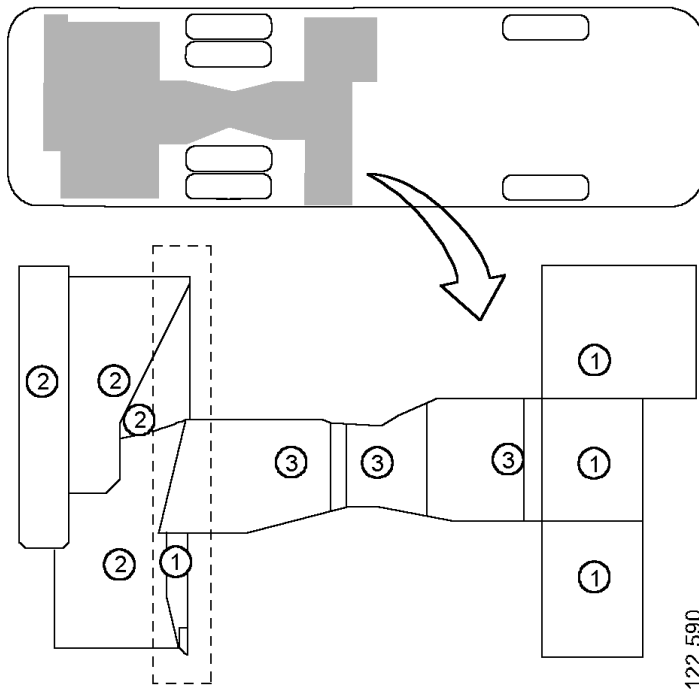

1 The spacing between the screws should be 100 mm.

2 The spacing between the screws should be 200 mm.

3 The spacing between the screws should be 400 mm.

Within the marked area the spacing between the screws should be 100 mm.