

**SCANIA**

**18:10-52**

Issue 2 **en**

# Articulation bellows

## Work description

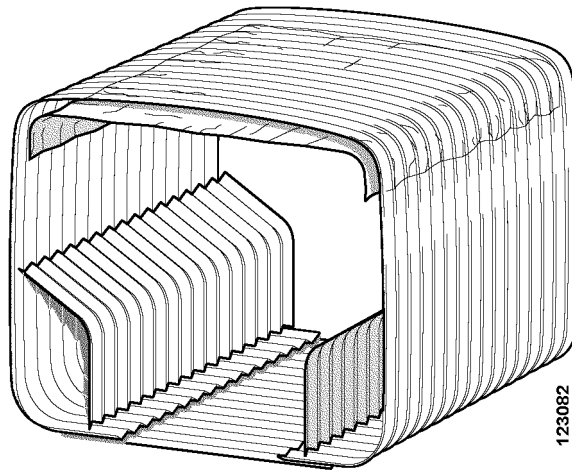

# Contents

Work description	General .....	3
	Ceiling covering .....	4
	Inner bellows .....	6
	Lower bellows .....	7
	Outer bellows.....	10
	Slide bearing and support roller in the roof.....	13
	Support wheel.....	15
	Outer bellows, repairing damage.....	16

# Work description

## General

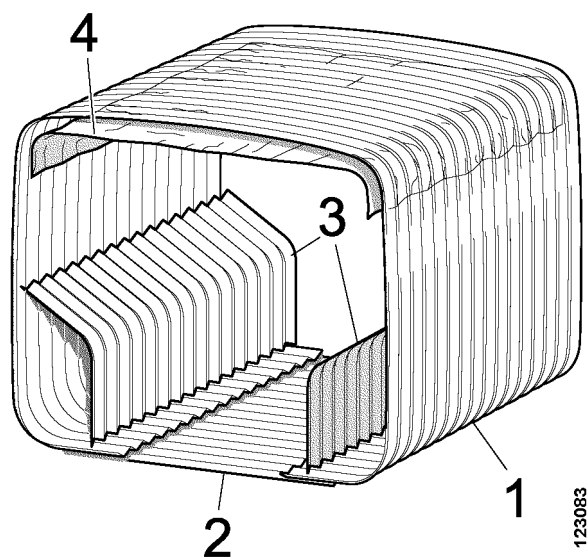

- 1 Outer bellows
- 2 Lower bellows
- 3 Inner bellows
- 4 Ceiling covering

## Ceiling covering

### Renewal

1 Loosen the ceiling covering at the edges. Remove the screwed rail at the front and rear edges of the ceiling covering (some models).

2 Remove the bottom rows of plastic clamps 1.

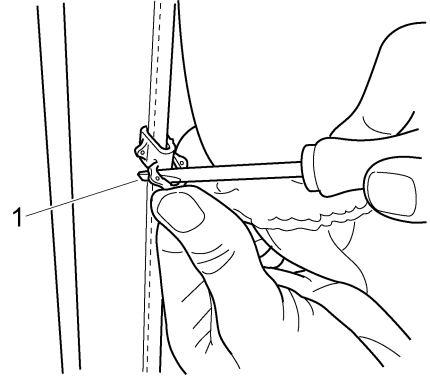

135659

3 Loosen the rails of the ceiling covering.

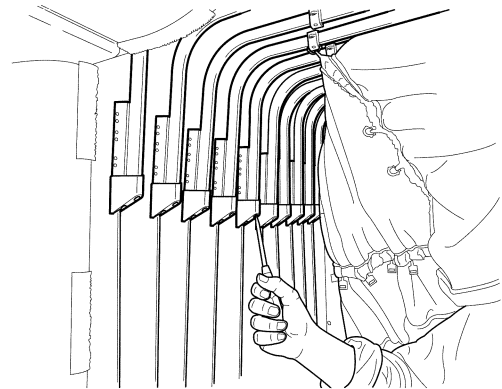

b113113

4 Lift up and unhook the rails and remove the ceiling covering.

5 Fit a new ceiling covering and hook the rails into place.

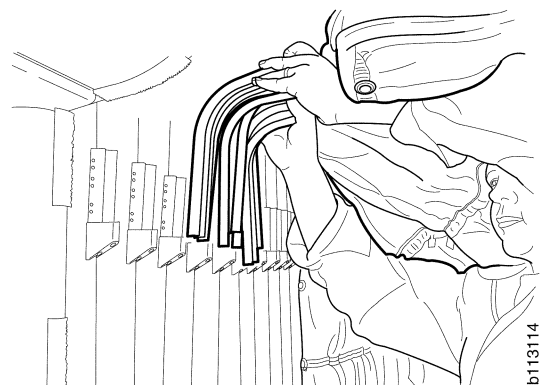

b113114

6 Screw on the rails.

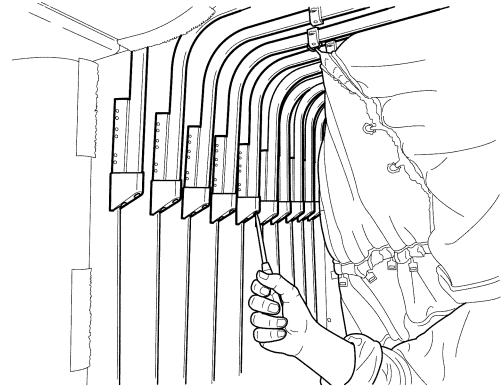

b113113

7 Fit the plastic clamps 1 and refit the ceiling covering.

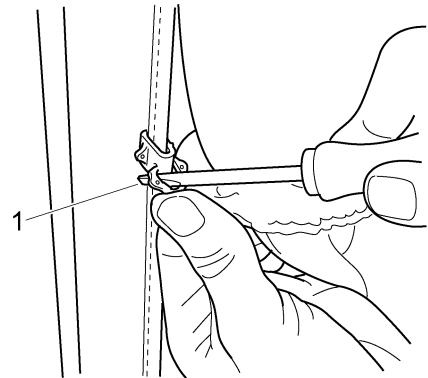

138659

# Inner bellows

## Specifications

### Materials

Petroleum jelly

## Renewal

- 1 Loosen and fold the lower edge of the ceiling covering to one side.
- 2 Drill out the rivets 1 and remove the metal piece. Remove the rubber moulding at the front edge 2 and rear edge 3 of the inner bellows.

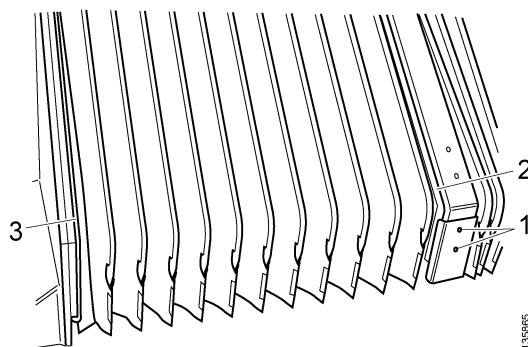

135985

- 3 Loosen the rails of the inner bellows at the upper and lower edges.

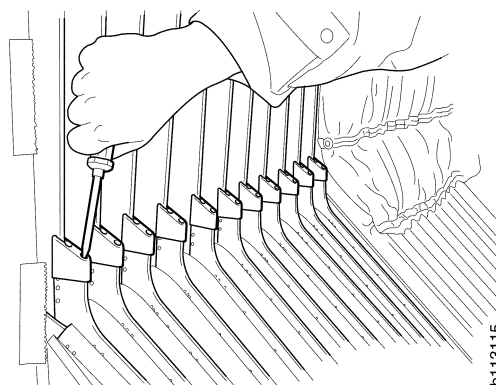

b113115

- 4 Unhook the rails and remove the inner bellows.
- 5 Fit the new inner bellows in reverse order. Lubricate the rubber mouldings using petroleum jelly to make fitting easier.

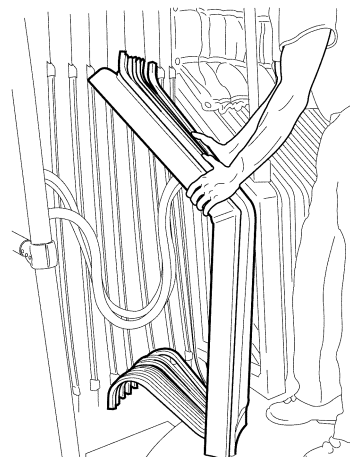

b113121

# Lower bellows

## Specifications

### Materials

---

Petroleum jelly

---

Plastic clamps for lower bellows

---

## Renewal

- 1 Remove the rubber moulding that holds the lower bellows at the front and rear edges.

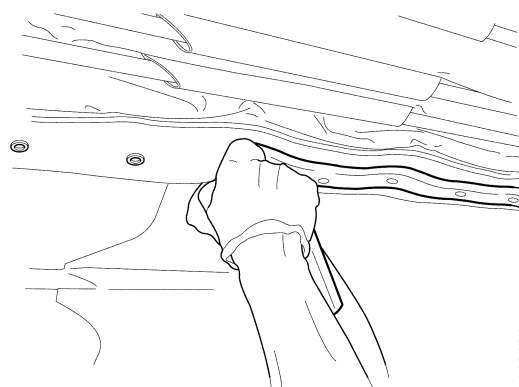

b113124

- 2 Remove the bolts or the plastic clamps which secure the rails to the outer bellows and pull out the rails.

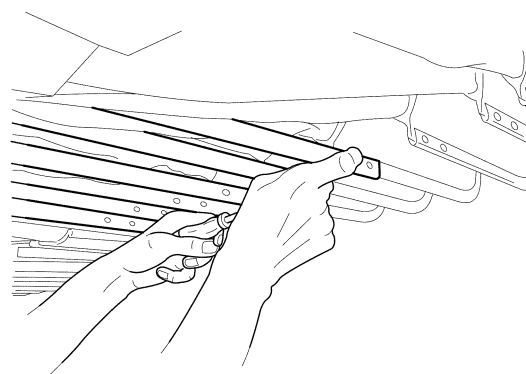

b113122

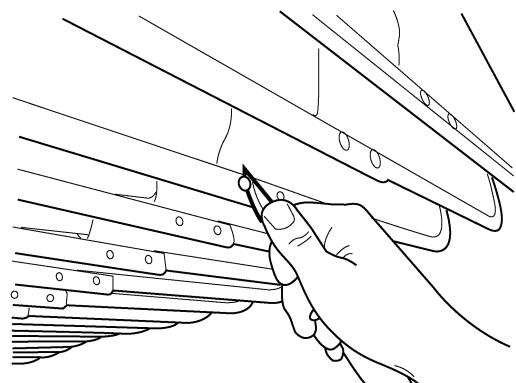

135967

- 3 Loosen the Velcro at the outer edges of the lower bellows.

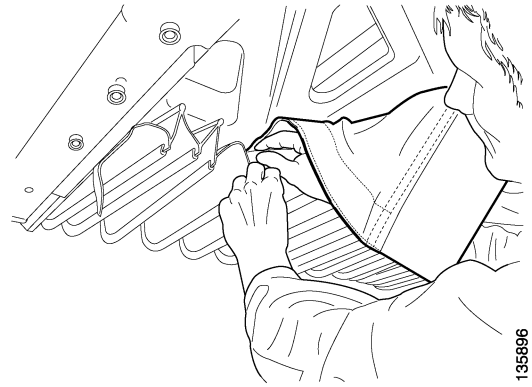

- 4 Remove the lower bellows by pulling the centre strip from the groove. Renew the lower bellows.

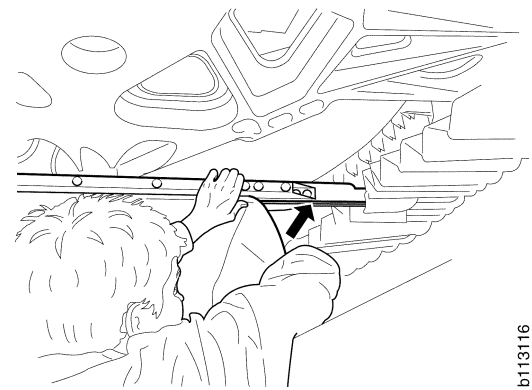

- 5 Apply petroleum jelly to the groove. Feed the centre strip of the lower bellows into the groove.
- 6 Secure the outer edges of the lower bellows with the Velcro. Ensure that the slots in the Velcro are aligned with the fold of the outer bellows.

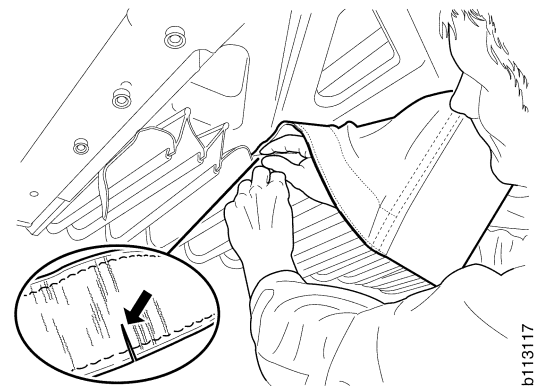

7 Fit the rails to the outer bellows.

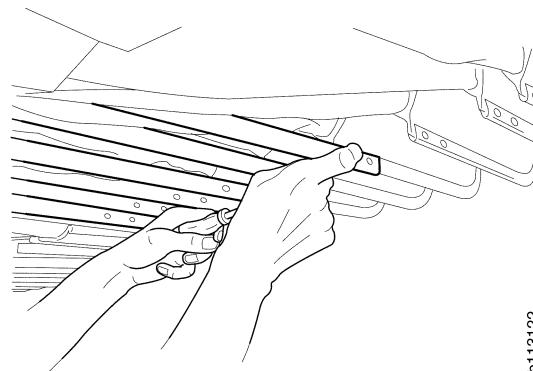

b113122

8 Secure the lower bellows at the front and rear edges using the rubber mouldings. If fitting new lower bellows, new holes must be made in the lower bellows.

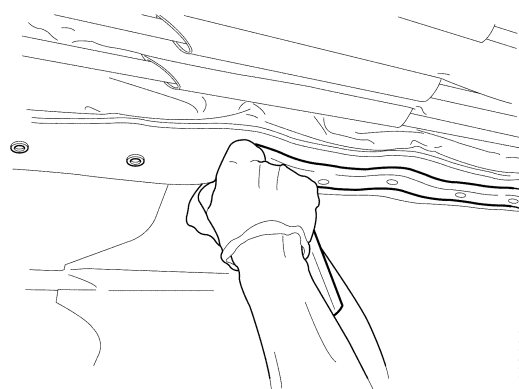

b113124

# Outer bellows

## Specifications

### Tightening torques

Tensioning device	10 Nm
-------------------	-------

### Materials

Petroleum jelly

## Renewal

- 1 Remove the lower bellows, inner bellows and the ceiling covering, refer to Lower bellows, inner bellows and ceiling covering.
- 2 Remove any seats, railing or other equipment in the articulation unit.
- 3 Loosen the tensioning devices at the lower edge of the outer bellows.

**OmniCity:** Loosen the nuts 1 and unhook the tensioning devices 2.

**OmniLink:** Turn the tensioning device 3 so that it releases the cables from the outer bellows.

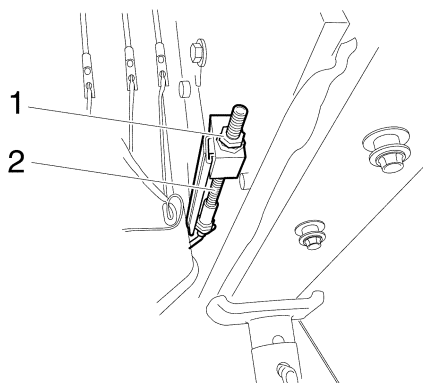

b113123

*Tensioning device, OmniCity*

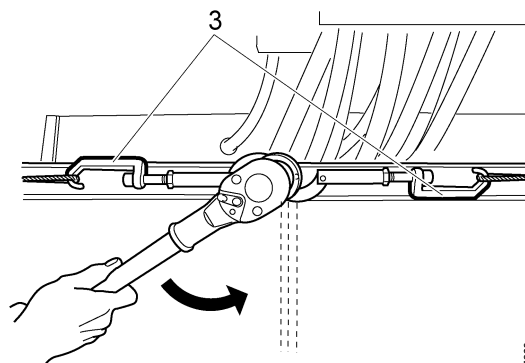

135969

*Tensioning device, OmniLink*

- 4 Pull the outer bellows 1 and the rubber moulding 2 out of the groove around the whole joint. Note how the rubber moulding is fitted in the groove.

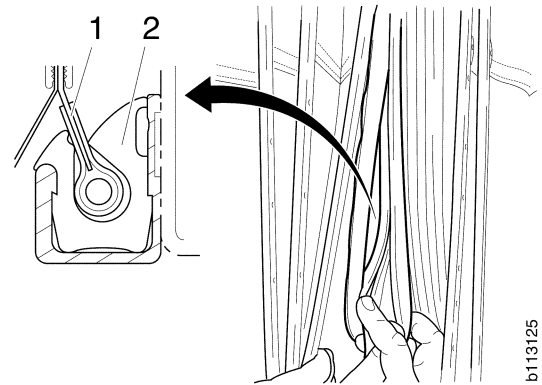

b113125

- 5 Remove the outer bellows and lift a new one into place. The job will be easier if there are three people, one on the inside and two on the outside.



b113126

- 6 Slip the rubber moulding 2 onto the outer edge of the outer bellows 1.

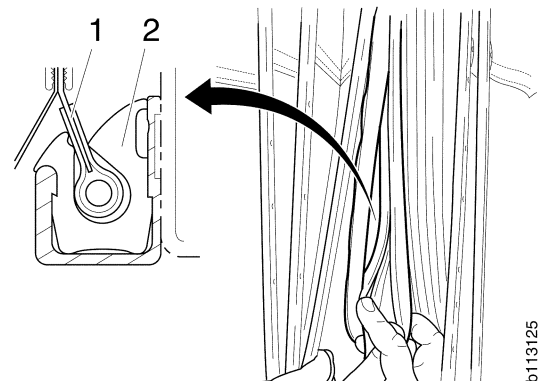

b113125

- 7 Lubricate the rubber moulding using petroleum jelly, then tap it into place. Begin at the centre of the bus roof. Check from the inside that the rubber moulding is correctly located in the groove.



b113130

- 8 Hook on the tensioning devices and tension the outer bellows. Torque tighten the nut to 10 Nm and tighten the lock nut.

**OmniCity:** Torque tighten the nut to 10 Nm and finally tighten the lock nut.

**OmniLink:** Adjust if necessary on the tensioning device bolts 2.

- 9 Install the lower bellows, inner bellows and the ceiling covering, refer to Lower bellows, inner bellows and ceiling covering.

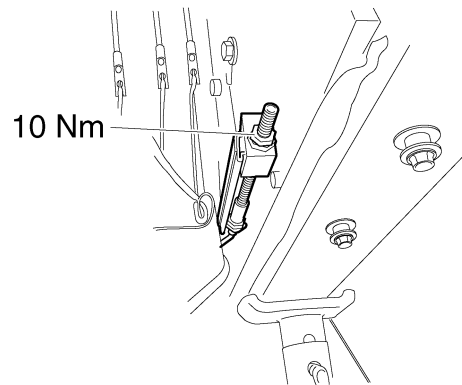

135891

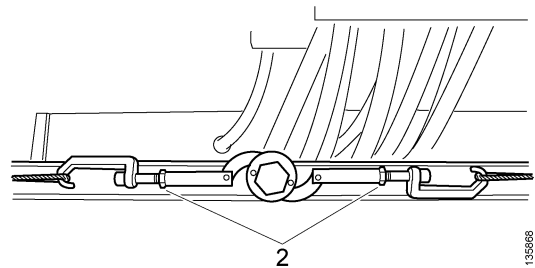

135868

## Slide bearing and support roller in the roof

### Renewal

- 1 Loosen the ceiling covering in the middle and pull it away.
- 2 Undo the bolts 1 on the slide bearing rollers.

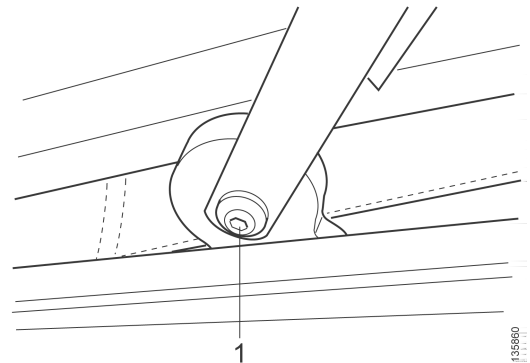

- 3 Mark the position of the slide rail 3 to make fitting easier.
- 4 Remove the angle bracket on one side (remove the bolts 2) and leave it in position on the other side (remove the bolts 1). This will make fitting easier.

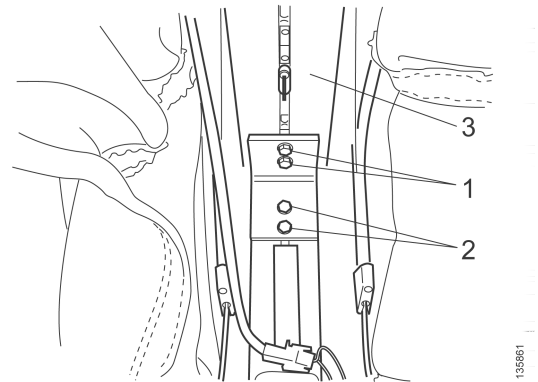

- 5 Lift down the slide rail 5.



- 6 Renew the slide bearings 4.

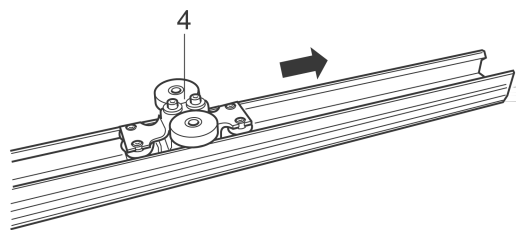

135682

- 7 Remove the support roller 1 and fit a new one. (Applies to buses built after December 2000).

**Note:** The support roller may also be renewed without removing the slide rail.

- 8 Assemble in reverse order.

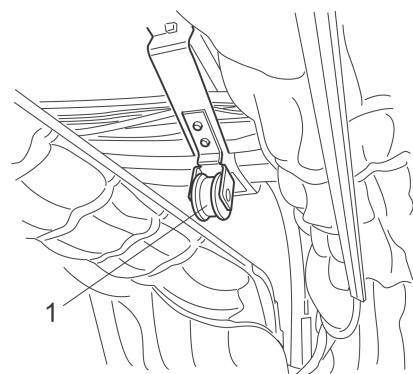

135684

# Support wheel

## Renewal

- 1 Remove a section of the inner bellows so that the support wheel is visible, refer to Inner bellows.
- 2 Undo the four bolts and renew the support wheel 1.
- 3 Adjust the height of the support wheel so that it is just touching the floor.

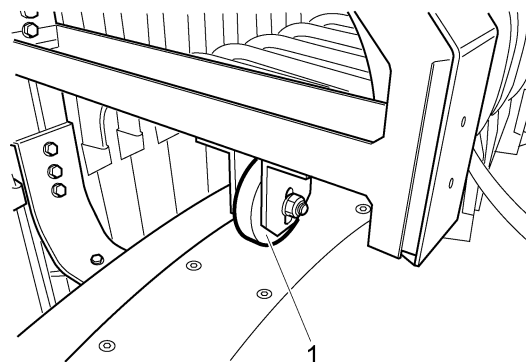

135966

## Outer bellows, repairing damage

Scania supplies a repair kit for repairing damage to outer bellows. The special tools which may be required are supplied by Hübner, the supplier of the articulation bellows.

### Specifications

#### Materials

---

Vulcanising adhesive

---

Cleaning primer

---

#### Outer edges

- If the aluminium sections on the outer edges of the outer bellows have been damaged, a repair section is riveted onto the damaged aluminium section.

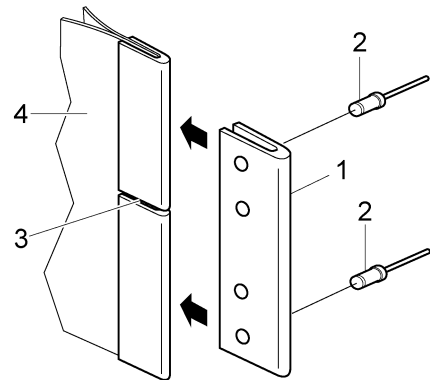

135656

## Sides of outer bellows

- 1 Clean the surface around the damaged area carefully, use cleaning primer. Roughen the surface.
- 2 Cut out a repair patch of a suitable size, the corners should be rounded. Roughen the surface of the repair patch.
- 3 Clean the surfaces again, on both the outer bellows and the repair patch. Use cleaning primer.
- 4 Apply adhesive to both surfaces and allow to dry for approximately 10 minutes.
- 5 Press on the repair patch and fix it in position, e.g. by using a screw clamp. Place a piece of wood or similar as a counterhold on the inside of the outer bellows.

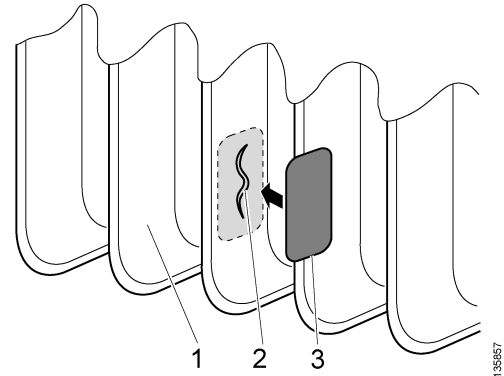

## Inner edges

- Damage to the inner edges of the outer bellows is repaired by securing aluminium repair pieces 1 over the damaged part of the outer bellows, between the joints 2.

