

SCANIA

01:01-52

Issue 2 **en**

9 litre engine

K bus

Removing and fitting

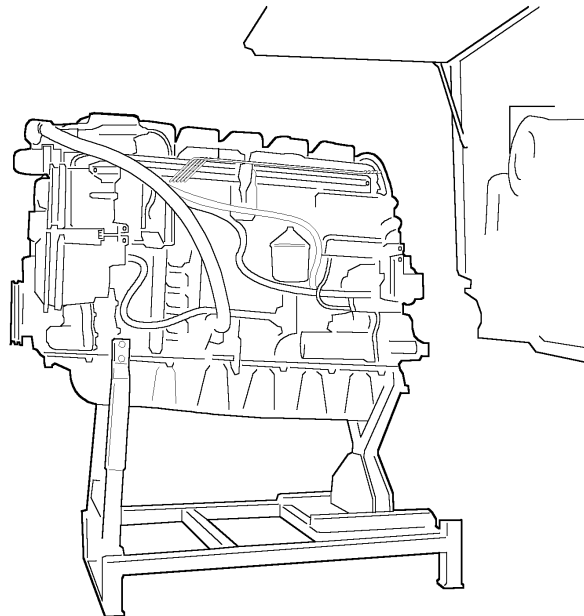

122-468





1 713 270

Contents

Removing the engine	Special tools.....	3
	Other tools	4
	Preparatory work	5
	Rear engine cover	6
	Right side cover	8
	Floor cover over gearbox.....	10
	Floor cover over engine.....	12
	From below.....	14
	Crossmember and engine brackets	16
	Engine support.....	18
Fitting the engine	Specifications.....	20
	Preparatory work	21
	Crossmember and engine brackets	22
	From below.....	24
	Floor cover over gearbox.....	26
	Floor cover over engine.....	28
	Right side cover	30
	Rear engine cover	32

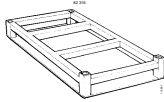
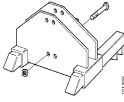
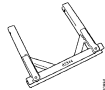
Removing the engine

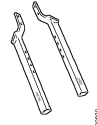
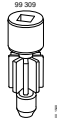
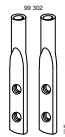
Special tools

Number	Designation	Illustration	Tool board
82 316	Engine support		
2 271 841	Rear lower engine support		
2 271 840	Front lower engine support		
2 271 842	Rear upper engine support		
82 346	Gearbox support		
2 271 864	Front upper engine support		
99 309	Torsion tool (for vehicles with automatic gearbox)		
99 302	Tips		D5
99 301	Adapter		D5

Other tools

Number	Designation
584 054	Torque wrench
587 129	Coolant tank
587 585	Pliers

Preparatory work

IMPORTANT! Clean the engine before starting the work. Always use protecting plugs, cover plates, etc. to plug exposed connections and openings so that dirt does not penetrate into the engine.

IMPORTANT! Help protect our environment. Avoid spillage. Use a suitable container.

Note: The work of removing and fitting the engine should be carried out using wheel lifts.

- 1 Lower the suspension by releasing the air from the bellows. On vehicles with ELC, there is one bleeder nipple for the front axle and there are two for the rear axle.

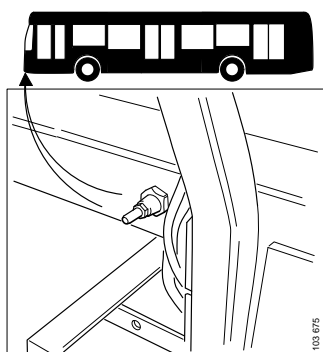

Rear bleed nipples on vehicles with ELC

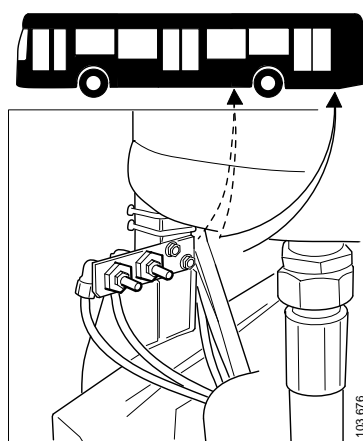

Rear bleed nipples on vehicles with ELC

- 2 Remove the negative battery cable.
- 3 Remove the covers in the floor above the engine and above the gearbox.
- 4 Open the rear engine cover on the bus.
- 5 Remove the rear bumper.

Rear engine cover

Pos.	Designation	Comments
1	2 heating system valves	Note: Close the valves in the bus heating system. Drain the cooling system. Use coolant tank 587 129.
2	Coolant pipe bolts	Remove the coolant pipe bolts.
3	Bleeder hoses on expansion tank	Detach the bleeder hoses from the expansion tank.
4	Coolant hose	Detach the coolant hose from the expansion tank.
5	Expansion tank clamps	Undo the expansion tank clamps. Remove and tie up the expansion tank at a level above the rocker covers.
6	Coolant hose (venting)	Disconnect the upper coolant hose to the engine at the intake manifold.
7	Upper clamp for charge air pipe	Undo the upper clamp for the charge air pipe between the charge air cooler and the intake manifold.
8	Lower clamp for charge air pipe	Undo the lower clamp for the charge air pipe between the charge air cooler and the intake manifold.
9	Charge air pipe bracket	Undo the clamp and remove the charge air pipe between the charge air cooler the and intake manifold.
10	Compressor relief hose	Remove the compressor relief hose.
11	Valve for A/C compressor air bellows	If the vehicle is equipped with A/C, turn the tap clockwise to close the valve and release the air from the air bellows.
12	A/C compressor mounting plate	Fit a tommy bar in the square 1/2 inch hole at the end of the A/C compressor mounting plate. Turn the compressor mounting plate and remove the compressor drive belt.

Working from the rear engine cover

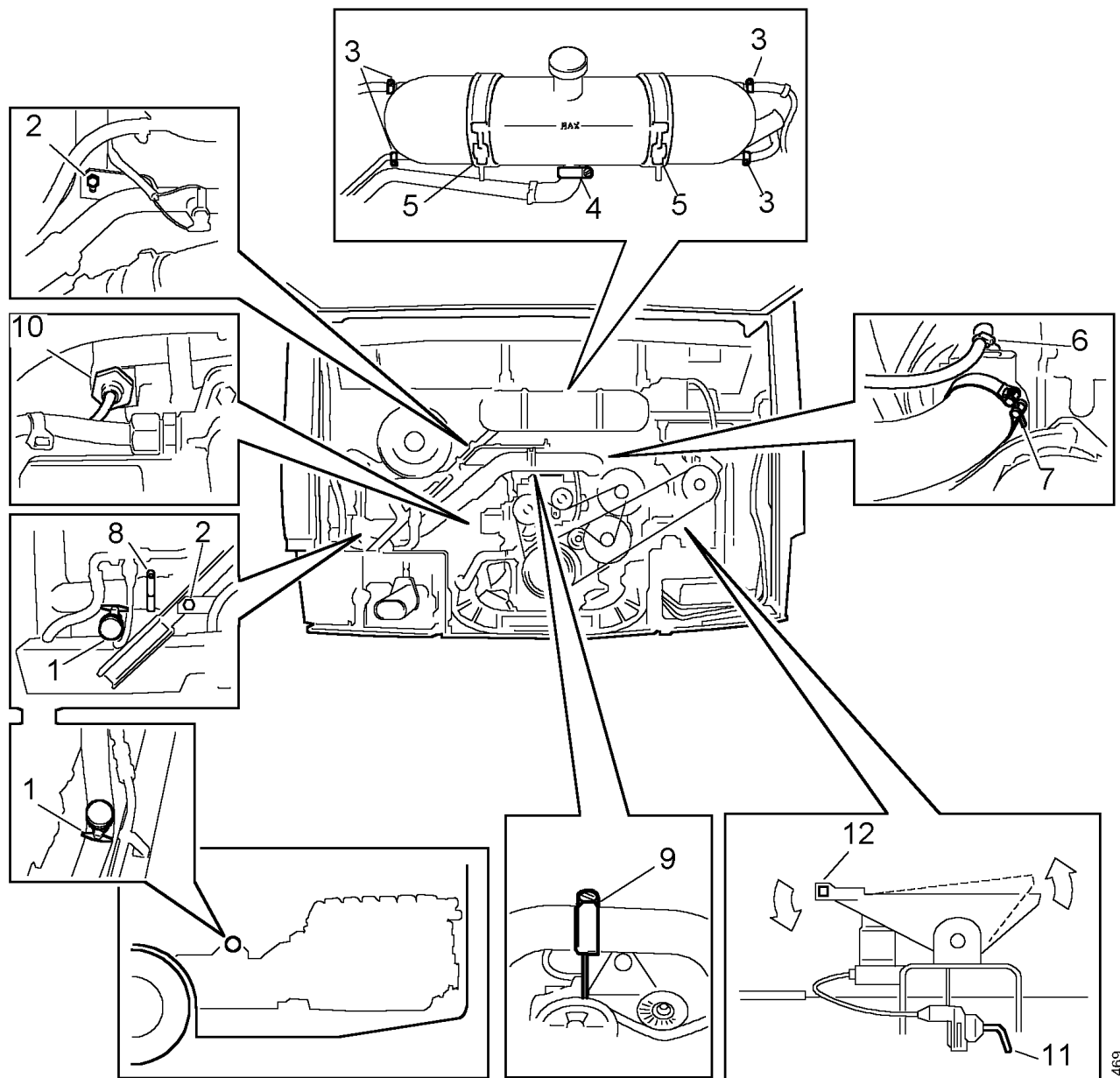

122 469

Right side cover

Pos.	Designation	Comments
1	Fuel pipes	Mark the fuel lines. Separate and plug the fuel lines.
2	Connector C516	Separate connector C516.
3	Junction box	Open and mark all connectors in the junction box. Separate all connectors.
4	Coolant hose	Remove the coolant hose from the pipe above the intake manifold at the rear edge of the engine.
5	Throttle wire	Remove the throttle wire if the vehicle is equipped with a mechanical throttle control. If the vehicle is equipped with a speed limiter, remove the hose to the speed limiter air piston.
6	Suction pipe to hydraulic pump	Drain the hydraulic fluid reservoir. Separate and plug the connections for the suction pipe to the hydraulic pump.
7	Hydraulic line	Separate and plug the hydraulic line.
8	Hydraulic line to power steering gear	Separate and plug the connections for the hydraulic line to the power steering gear.
9	Upper nut for hydraulic pump	Remove the upper nut for the hydraulic pump.

Working from the right side cover

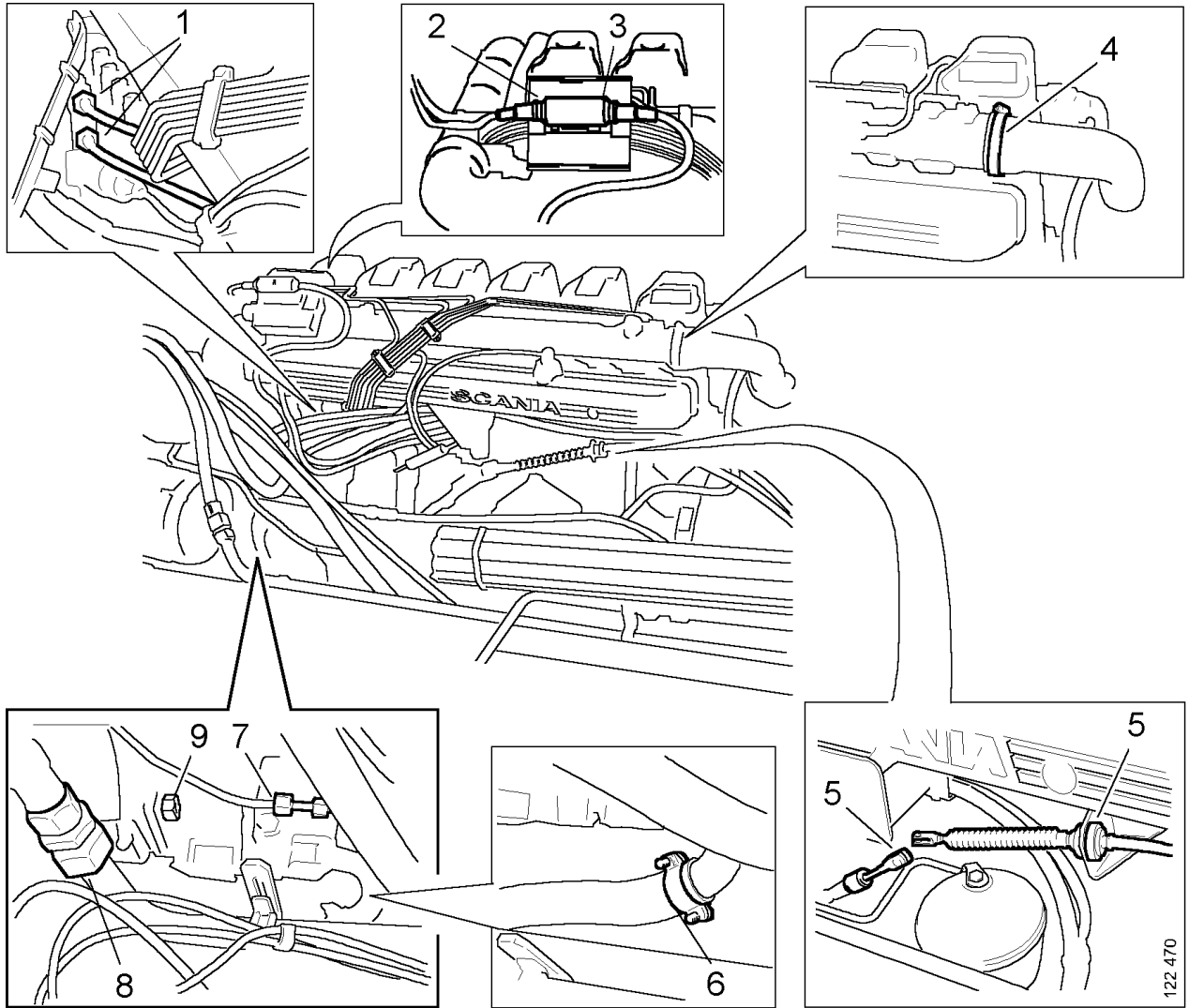

Floor cover over gearbox

Pos.	Designation	Comments
1	Nuts for gearbox and engine	Remove the upper nuts which hold together the engine and gearbox.
2	Hydraulic line to power steering gear	Separate and plug the hydraulic line to the power steering gear.
3	Compressed air pipe	Separate the and plug the compressed air pipe for the operating air to the exhaust brake.
4	Clutch retaining ring *)	Fit pliers 587 585 with tips 99 302. *)

*) On some vehicles with alternative equipment it may be easier to fit the pliers 587 585 for the clutch retaining ring from below. Alternatively a flattened pipe with an internal diameter of 15 mm can be used to hold together the clutch retaining ring.

Removing parts through the floor cover over the gearbox

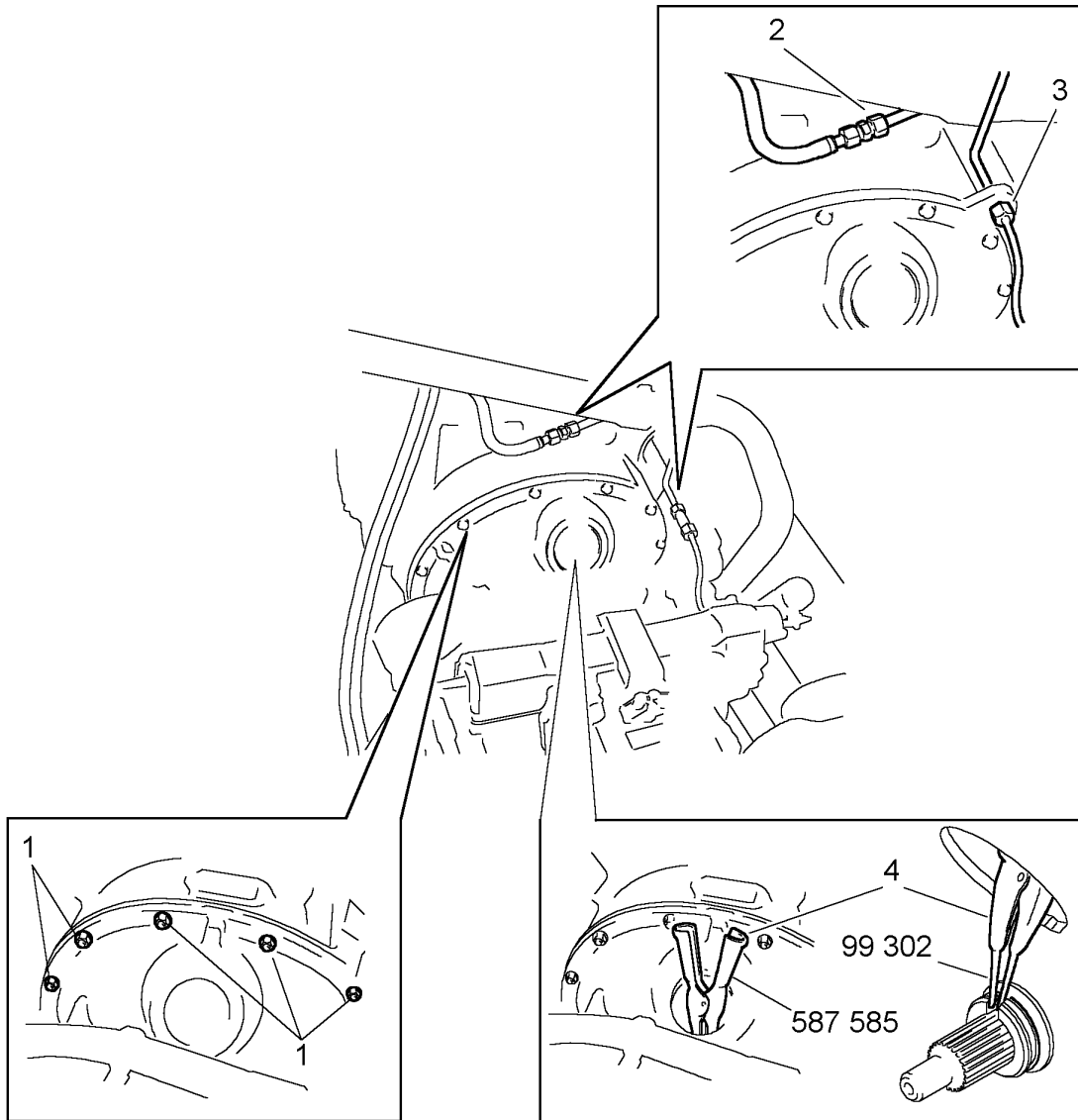

122 472

Floor cover over engine

Pos.	Designation	Comments
1	V-clamp	Undo the V-clamp and fold aside the charge air pipe between the charge air cooler and turbocharger unit.
2	Compressor air hose	Detach the air hose to the compressor.
3	Clamp	Undo the clamp at the turbocharger unit for the pipe to the air cleaner.
4	Clamp	Undo the clamp at the air cleaner and remove the pipe between the air cleaner and turbocharger unit.
5	Cooling coil pipe	Separate and plug the cooling coil pipe.
6	Compressed air pipe	Separate the compressed air pipe for the operating air to the exhaust brake.
7	V-clamps	Undo the V-clamps and the exhaust brake bracket. Remove the flexible exhaust pipe together with the exhaust brake.

Removing parts through the floor cover over the engine

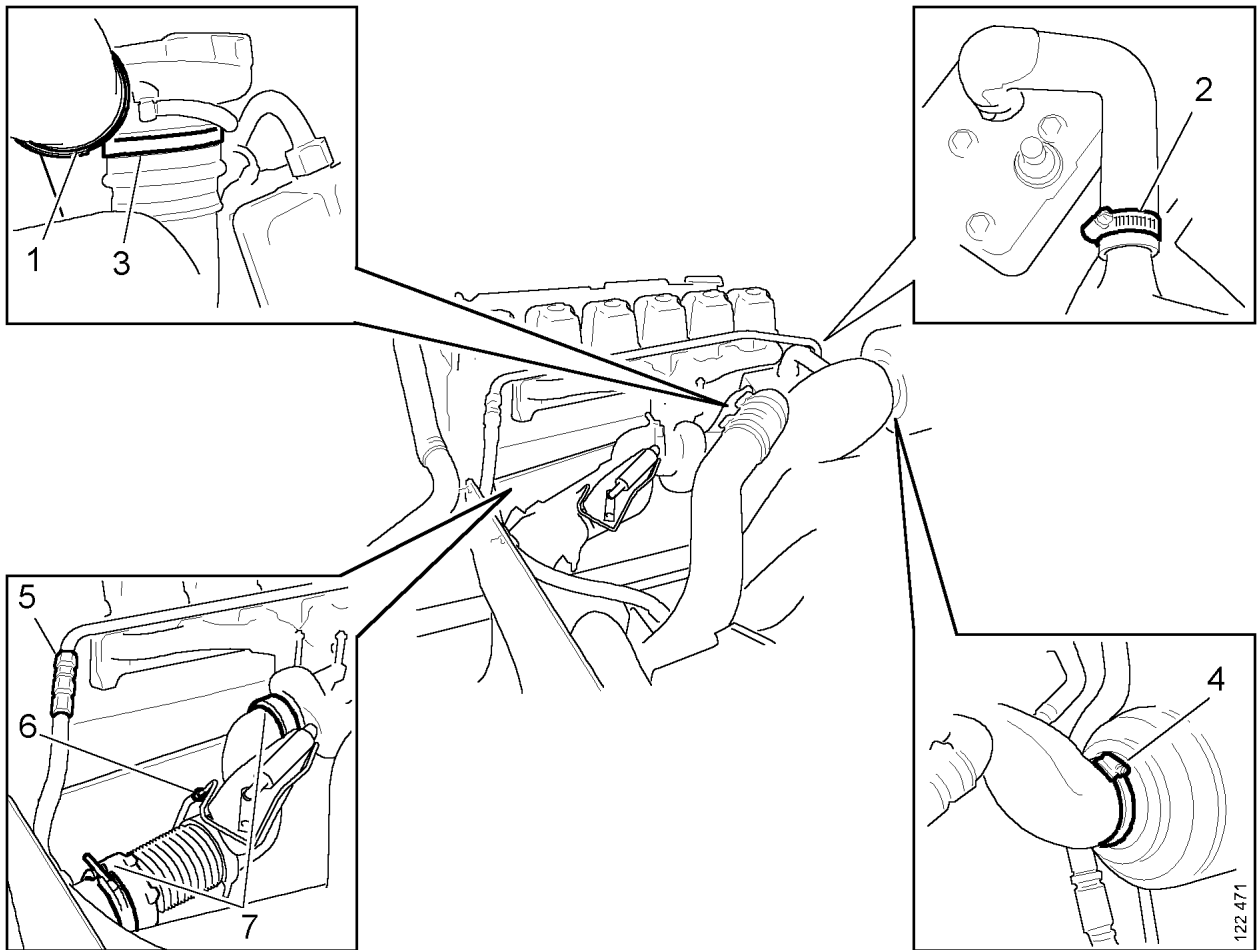

From below



Always use stands to support the vehicle when working under a vehicle. Always place axle stands under the frame when working underneath vehicles with air suspension. Empty the air bellows.

Raise the vehicle with wheel lifts.

Remove cover plates and covers beneath the engine and gearbox. Also remove the rails on the right and left frame members which hold the cover plates to obtain greater clearance for the tools and engine.

Pos.	Designation	Comments
1	Ground connection and starter motor connection	Remove the ground connection and the starter motor positive cable from the frame beside the starter motor.
2	Coolant hose	Detach the lower coolant hose.
3	Hydraulic hose	Separate and plug the hydraulic line to the fan.
4	Lower nut for hydraulic pump	Remove the lower nut which holds the hydraulic pump. Remove the pump.
5 *)	Torque converter bolts *)	Remove the protecting plug in the flywheel housing. Remove the 10 bolts which fasten the flex plate in the torque converter. *)

*) On vehicles with automatic gearbox.

Work from below

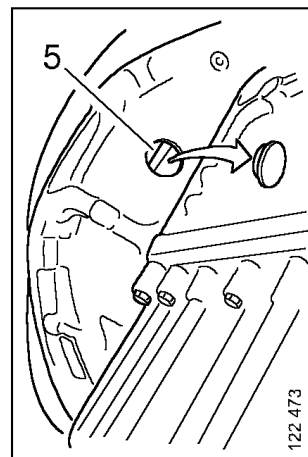
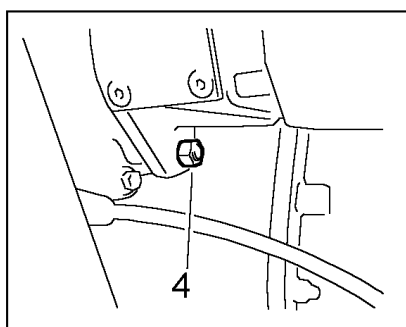
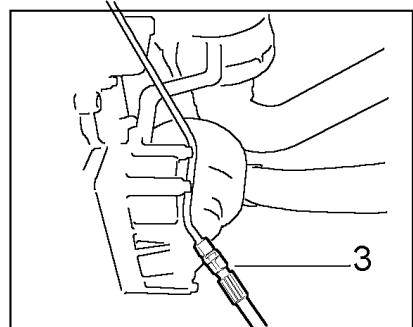
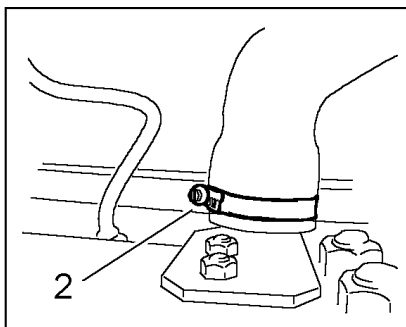
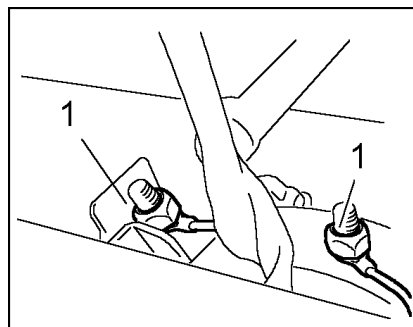

Crossmember and engine brackets

Lower the vehicle so that you can access the bolts for the crossmember and engine brackets.

Pos.	Designation	Comments
1	Clamp bolt	Remove the clamp screw and place the crankcase ventilation hose to one side.
2	Bolts in frame	Remove the 3 bolts on each side of the frame behind the rear crossmember.
3	Crossmember bolts	Also remove all the crossmember bolts apart from one on each side. Allow one bolt to remain in each corner. The engine remains suspended by the bolts.
4	Engine bracket nuts	Remove the upper nuts for the engine bracket.

Removing the crossmember and engine brackets

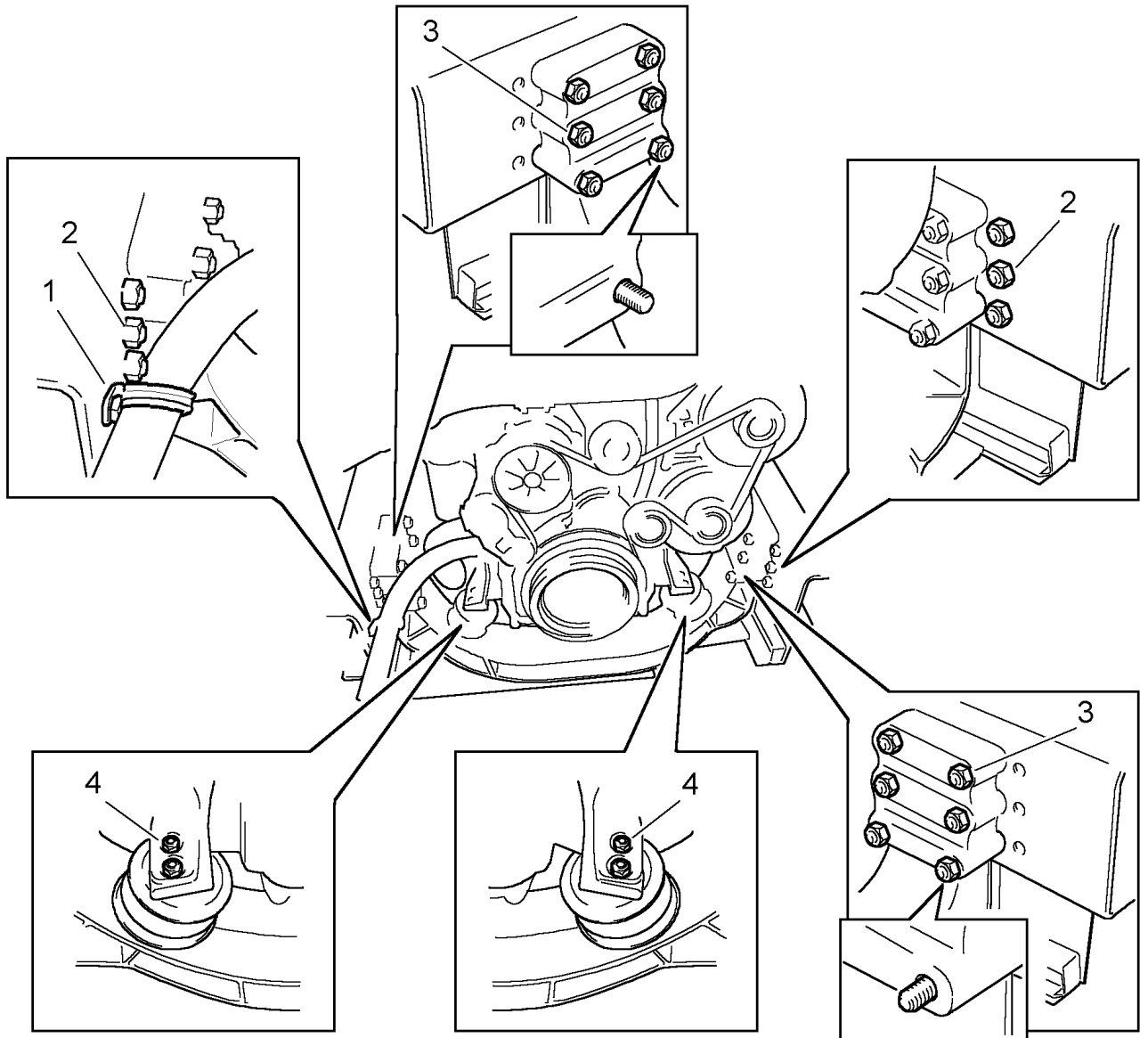

121 903

Engine support

Pos.	Designation	Comments
1 *)	Gearbox bracing tool 82 346 *)	Fit gearbox bracing tool 82 346 *) on the frame member which goes under the flywheel housing.
2	Front upper engine support 2 271 864	Fit the front upper engine support 2 271 864 on the engine.
3	Front lower engine support 2 271 840	Fit the front lower engine support 2 271 840 to the front upper engine support 2 271 864.
4	Rear lower engine support 2 271 841	Fit the rear lower engine support 2 271 841 to the engine support 82 316.
5	Rear upper engine support 2 271 842	Fit the rear upper engine support 2 271 842 to the rear lower engine support 2 271 841.
6	Engine support 82 316	Roll in engine support 82 316 using a pallet lifter.

*) If the vehicle is equipped with an automatic gearbox, remove the upper part of gearbox bracing tool 82 346 and support the automatic gearbox with the bolt.

Lower the vehicle with the wheel lifts so that you fit the height between the upper and lower strut of the engine support to suitable holes. It may be necessary to correct the height individually on the front and rear engine supports since the engine has approx 4 degrees inclination on the chassis.

Raise the engine stand to relieve the pressure on the engine brackets. Remove the last two bolts in the crossmember, and remove it.

Adjust the height of gearbox bracing tool 82 346 so that the gearbox is lying on the support.

Remove the last nuts which hold the engine and gearbox together and separate the engine and gearbox.

Pull out the engine from the engine compartment.

Use overhead hoists to move the engine from the engine stand.

Fitting the engine support and removing the engine

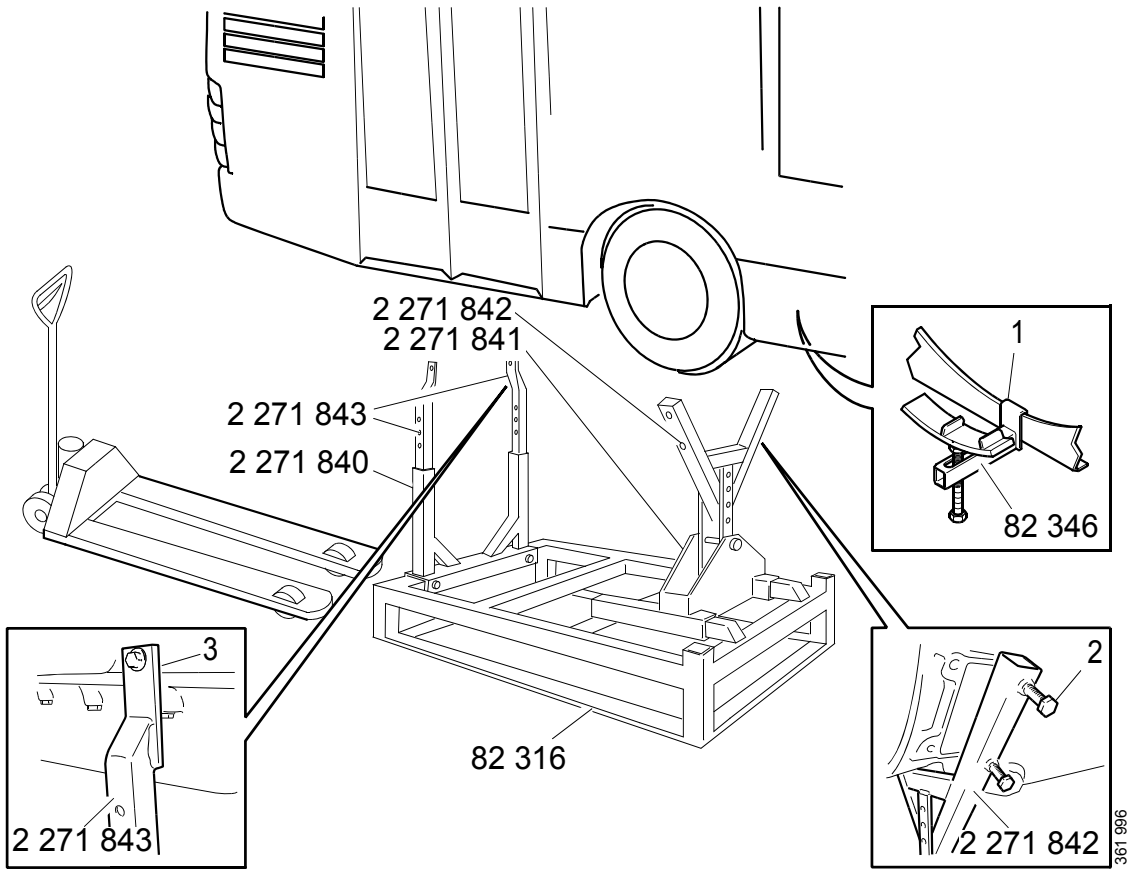

Fitting the engine

Specifications

Designation	Tightening torques
Crossmember bolt	210 Nm
Engine bracket bolts	47 Nm
V-clamp bolts	8 Nm
Bolts to attach gearbox to engine	47 Nm
Torque converter bolts	84 Nm

The following tightening torques apply in general unless otherwise specified:	Tightening torques
M5 thread	6.7 Nm
M6 thread	10.2 Nm
M8 thread	26 Nm
M10 thread	50 Nm
M12 thread	92 Nm
M14 thread	149 Nm

Preparatory work

Manual gearbox

Note: Replace clutch retaining ring. Check that the puller ring and its securing ring are intact and are correctly seated. Oil the spring pins with anticorrosive oil. Push the slave cylinder end into the assembly position until the spring pin is level with the rear edge of the heel.

- Align the engine and push it into position. When the slave cylinder end engages with the diaphragm spring locking device an audible click is heard.

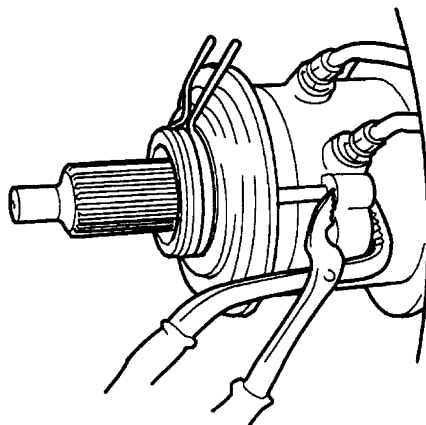

Automatic gearbox

- Align the engine and push it into position. Position the flywheel so that one of the flex plate holes is directly in front of the access hole in the flywheel housing.
- Then turn the torque converter so that the holes in the torque converter and flex plate are aligned. Use a screwdriver as a centering tool.
- Fit the engine to the gearbox and tighten the nuts holding the gearbox on to the flywheel housing. Tightening torque 47 Nm
- Bolt the flex plate on to the torque converter with 10 bolts. Turn the flywheel with torsion tool 99 309.

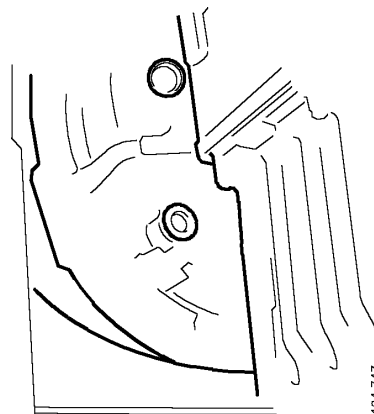

Tightening torque 84 Nm.

- Refit the protecting plug.

Crossmember and engine brackets

Pos.	Designation	Comments
1	Crossmember bolts	Fit the crossmember and tighten the bolts to 210 Nm.
2	Engine bracket nuts	Lower the engine in the engine brackets and tighten the nuts on both engine brackets to 47 Nm.
3	Bolts in frame	Fit the bolts on each side of the frame behind the rear crossmember.
4	Clamp bolt	Fit the bolt and clamp for the crankcase ventilation hose.

Fitting the crossmember and engine brackets

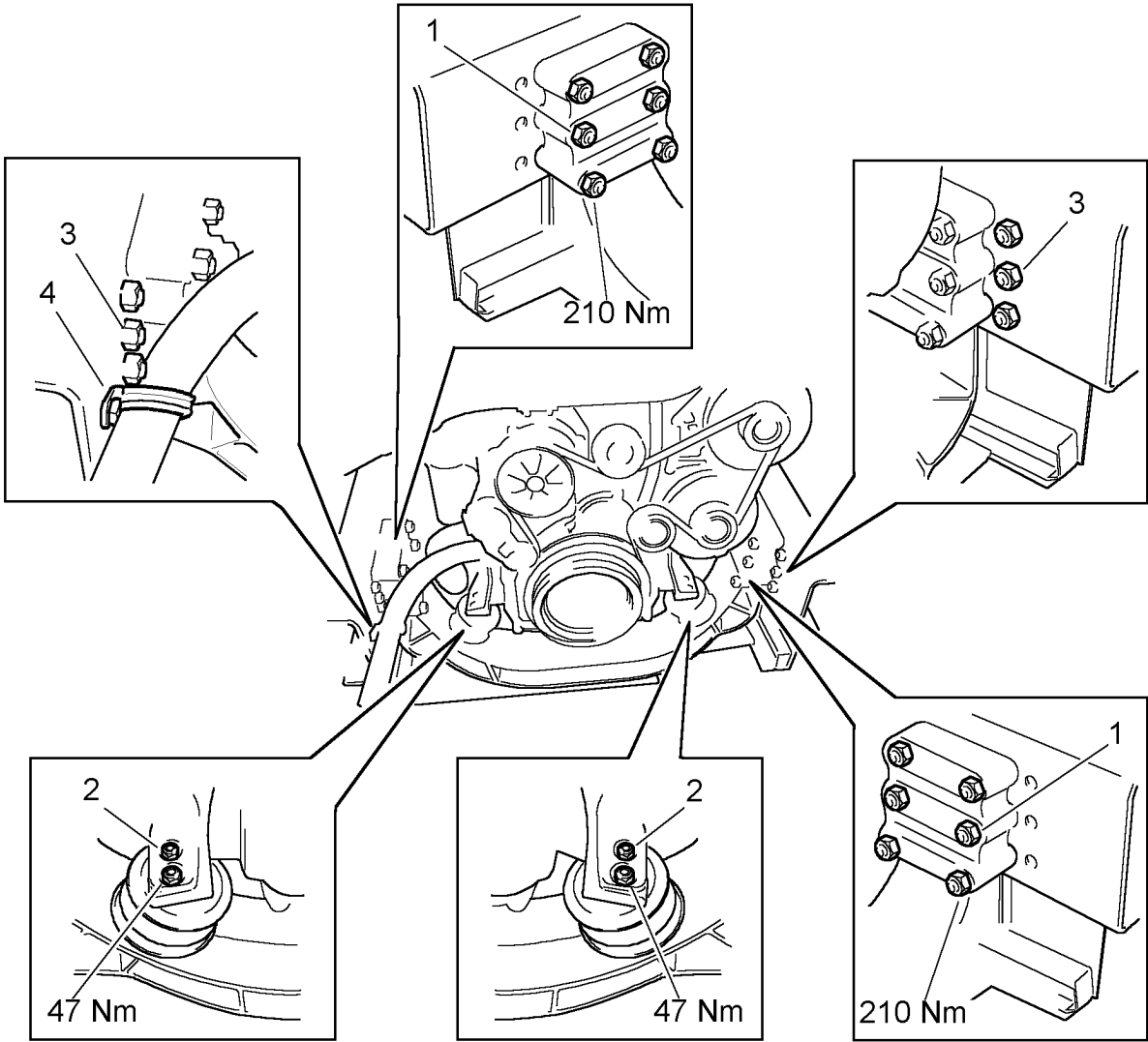

122 450

From below

Lower and remove the pallet lifter and all engine and gearbox supports.

Pos.	Designation	Comments
1	Ground connection and starter motor connection.	Fit the ground connection and the starter motor positive cable on to the frame beside the starter motor.
2	Coolant hose	Fit the lower coolant hose.
3	Hydraulic line	Assemble the hydraulic line to the fan.
4	Hydraulic pump	Fit the hydraulic pump and fit the lower nut for the hydraulic pump.
5 *)	Torque converter bolts *)	Fit the 10 bolts which fasten the flex plate in the torque converter. Tightening torque 84 Nm. Fit the protecting plug in the flywheel housing *)

*) On vehicles with automatic gearbox.

Fitting parts from below

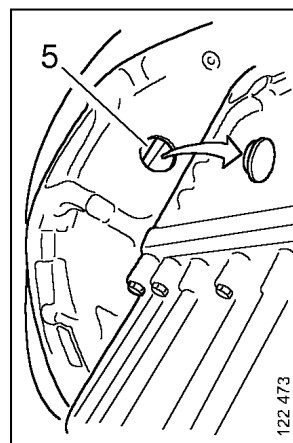
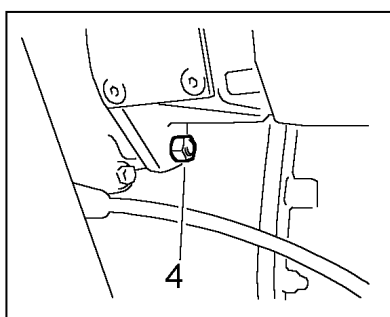
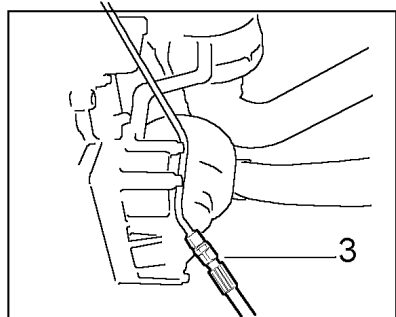
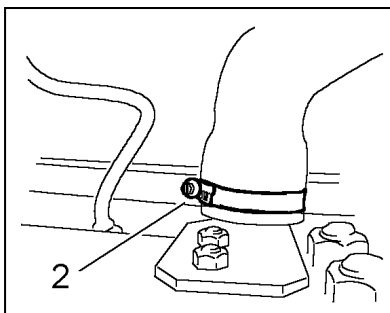
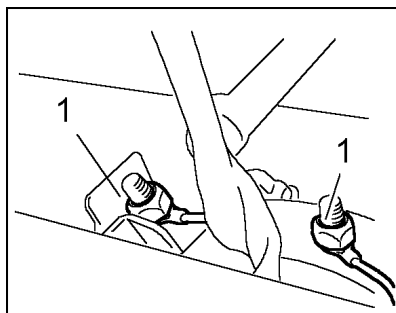

122 473

Floor cover over gearbox

Pos.	Designation	Comments
1	Nuts for gearbox and engine	Fit the upper nuts which hold together the engine and gearbox. Tightening torque 47 Nm.
2	Hydraulic line to power steering gear	Assemble the hydraulic line to the power steering gear.
3	Compressed air pipe	Fit the compressed air pipe for the operating air to the exhaust brake.

Fitting parts through the floor cover over the gearbox

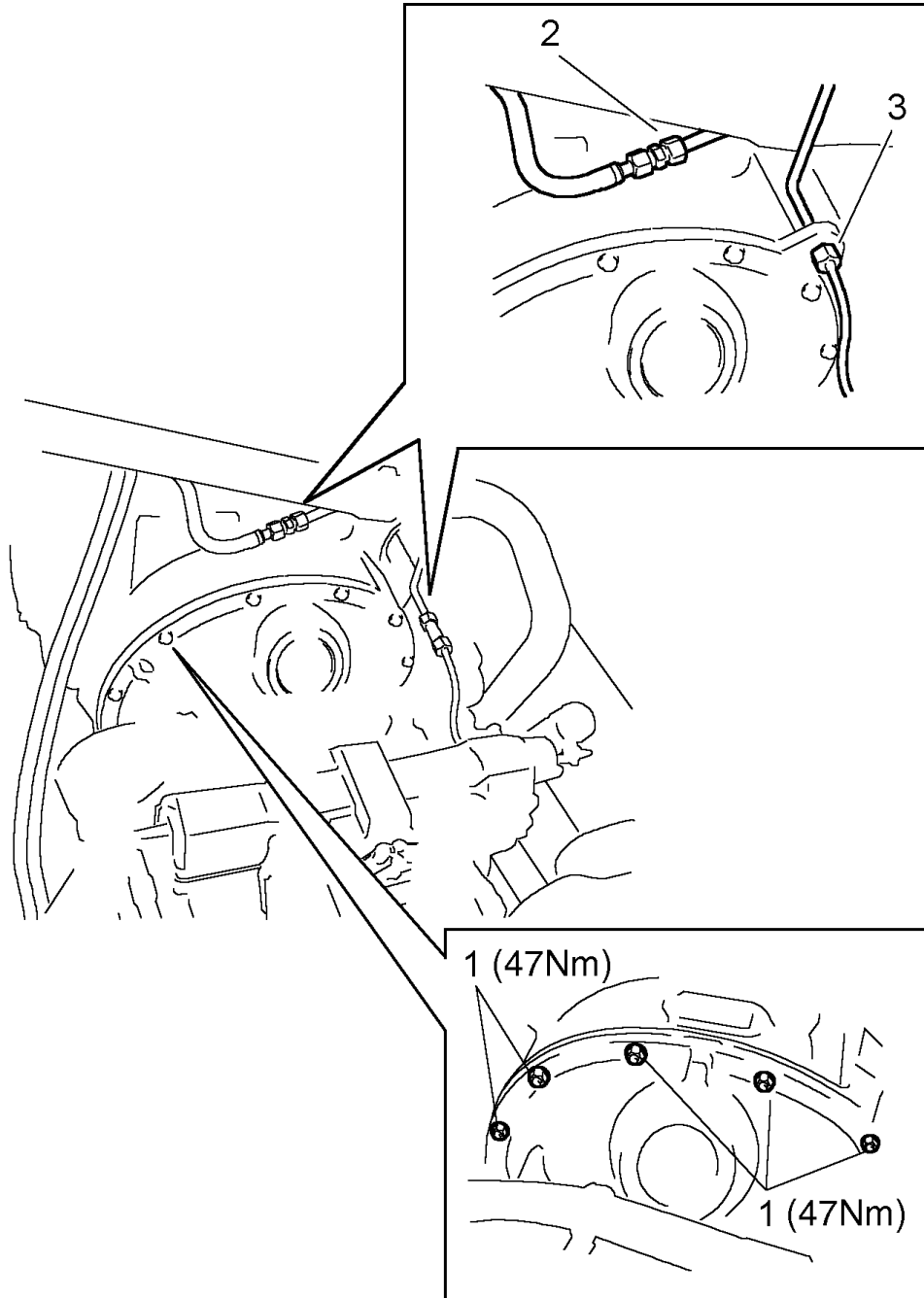

Floor cover over engine

Pos.	Designation	Comments
1	V-clamp	Fit the charge air pipe between the charge air cooler and turbocharger unit. Tightening torque 8 Nm.
2	Compressor air hose	Fit the compressor air hose.
3	Clamp for pipe to turbocharger unit	Fit the pipe to the air cleaner and the clamp at the turbocharger unit.
4	Clamp for pipe to air cleaner	Fit the clamp at the air cleaner.
5	Cooling coil pipe	Assemble the cooling coil pipe.
6	V-clamps	Fit the flexible exhaust pipe together with the exhaust brake. Fit the exhaust brake bracket. Tighten the V-clamps to 8 Nm. .
7	Compressed air pipe	Fit the compressed air pipe for the operating air to the exhaust brake.

Fitting parts through the floor cover over the engine

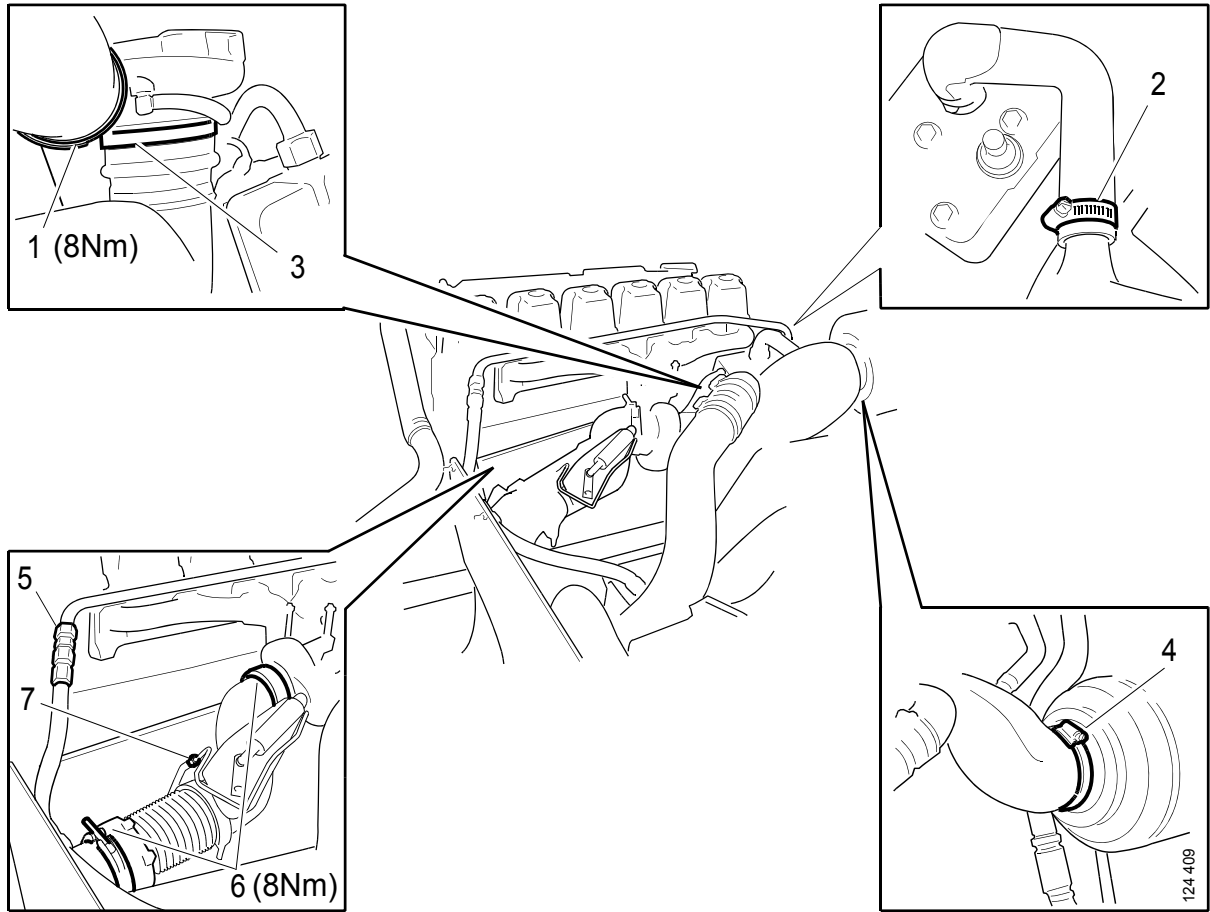

Right side cover

Pos.	Designation	Comments
1	Fuel pipes	Fit the fuel lines.
2	Connector C516	Assemble connector C516.
3	Junction box	Assemble all connectors.
3	Coolant hose	Fit the coolant hose from the pipe above the intake manifold at the rear edge of the engine.
4	Throttle wire	Fit the throttle wire if the vehicle is equipped with a mechanical throttle control. If the vehicle is equipped with a speed limiter, fit the hose for the speed limiter air piston.
5	Suction pipe to hydraulic pump	Fit the suction pipe on the hydraulic pump.
6	Hydraulic line	Assemble the hydraulic line.
7	Hydraulic line to power steering gear	Assemble the hydraulic line to the power steering gear.
8	Upper nut for hydraulic pump	Fit the upper nut for the hydraulic pump.

Fitting parts through the right side cover

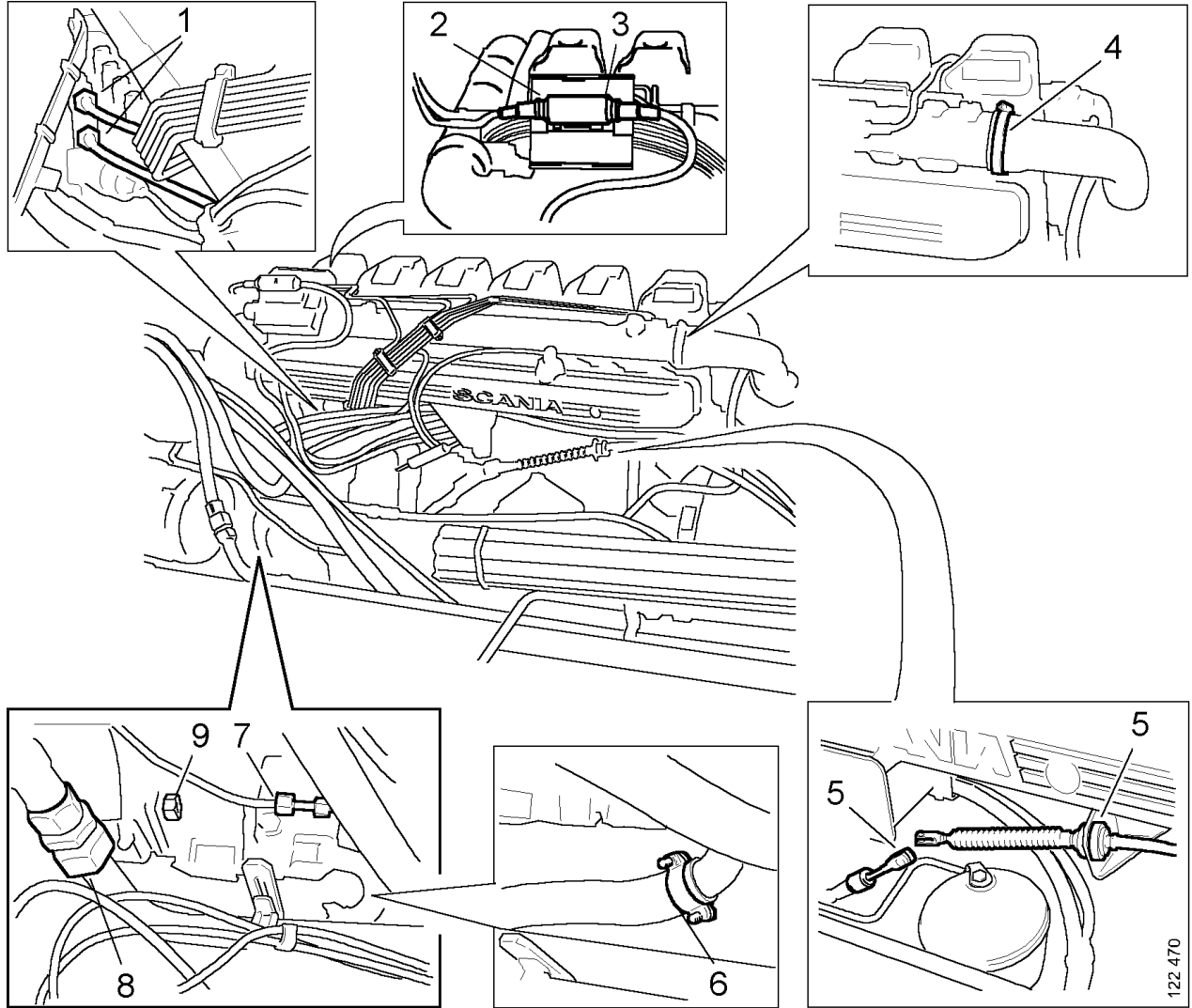

Rear engine cover

Pos.	Designation	Comments
1	Compressor relief hose	Fit the relief hose to the compressor.
2	Lower clamp for charge air pipe	Fit the charge air pipe between the intake manifold and charge air cooler and lower clamp. Tighten the clamp to 8 Nm.
3	Upper clamp for charge air pipe	Fit the upper clamp for the charge air pipe and tighten to 8 Nm.
4	Coolant hose	Fit the coolant hose above the intake manifold.
5	Expansion tank clamps	Fit the expansion tank clamps.
6	Bleeder hoses on expansion tank	Fit the bleeder hoses on the expansion tank.
7	Coolant hose	Fit the coolant hose on the expansion tank.
8	Coolant pipe bolts	Fit the coolant pipe bolts.
9	Charge air pipe bracket	Fit the clamp on the charge air pipe bracket.
10	A/C compressor mounting plate	Fit a tommy bar in the square 1/2 inch hole at the end of the A/C compressor mounting plate. Fold down the A/C compressor mounting plate and fit the AC compressor drive belt.
11	Valve for A/C compressor air bellows	Open the valve for the A/C compressor air bellows
12	2 heating system valves	Open the valves for the vehicle heating system.

Fit the rear bumper.

Fit the negative battery cable.

Fill with coolant. See Group 2.

Fill with hydraulic fluid. See Group 13.

Bleed the fuel system. See Group 3.

Fit the cover plates and covers beneath the engine.

Fitting parts through the rear engine cover

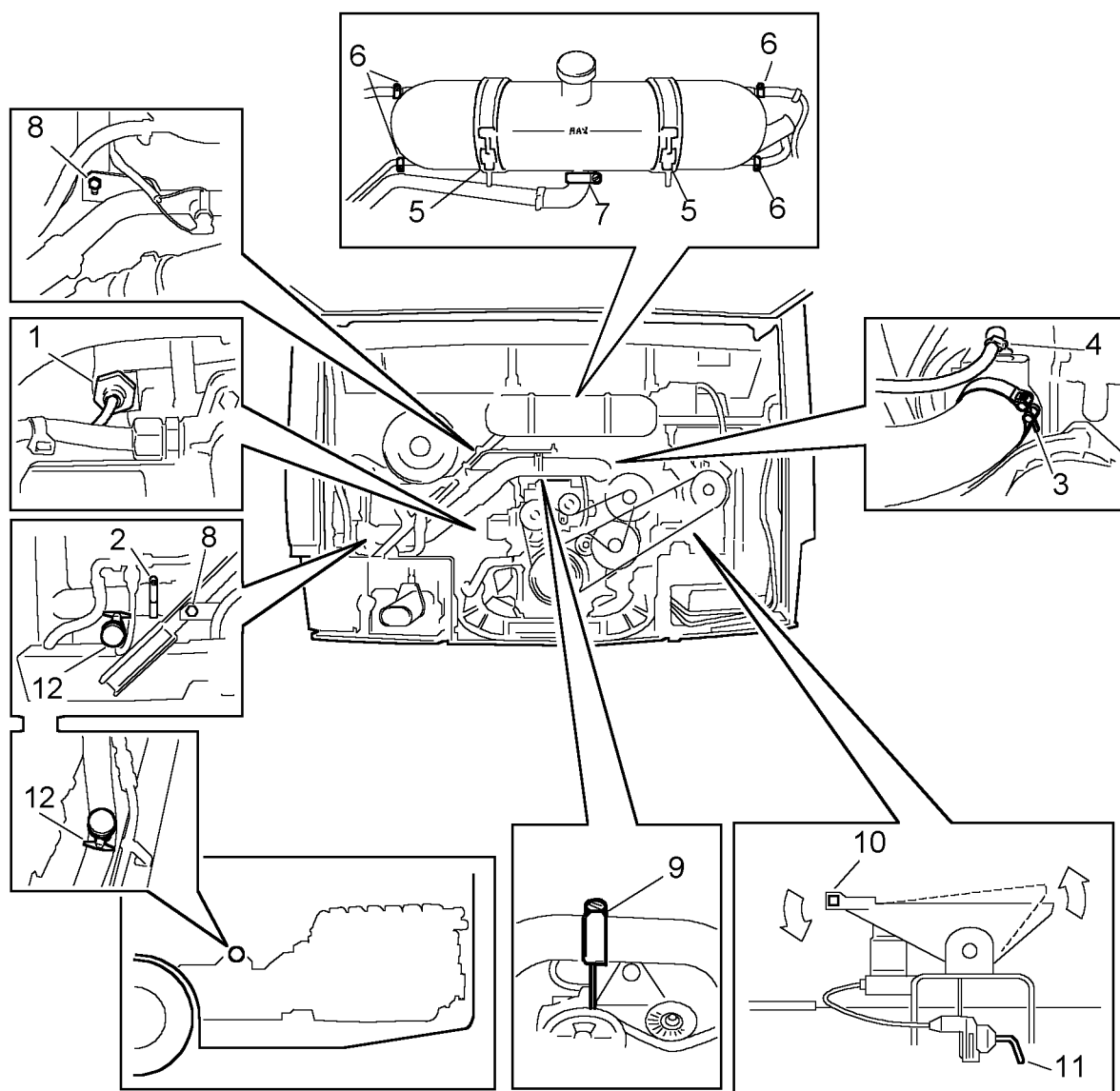

124 408