

SCANIA

05:01-05

Issue 1 en

Gearbox G701

Function and Work Description

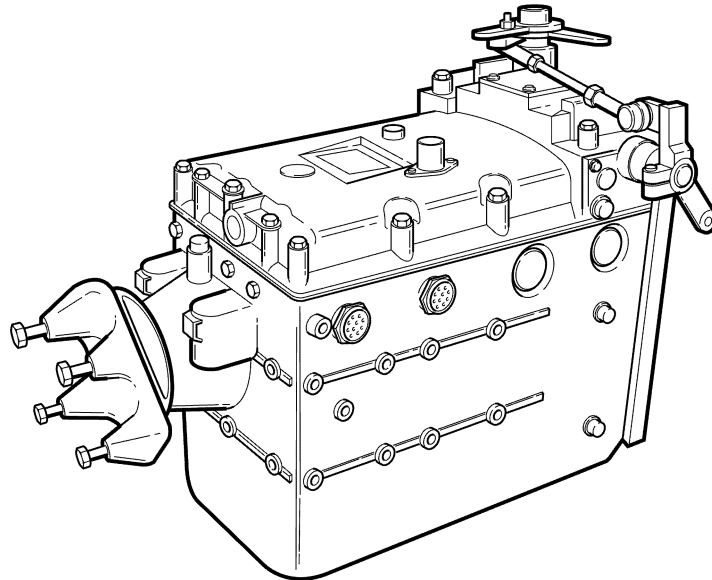

123682

Contents

| | | |
|----------------------|--------------------------------------|----|
| Function description | General | 3 |
| | Input shaft | 4 |
| | Mainshaft | 5 |
| | Countershaft | 6 |
| | Reverse gear shaft..... | 7 |
| | Synchromesh | 8 |
| | Controls | 10 |
| | General diagram | 10 |
| Work description | General | 11 |
| | Spot repairs | 12 |
| | Overhaul of selector housing..... | 14 |
| | Removal and fitting of gearbox | 18 |
| | Overhaul of gearbox | 30 |
| | Overhaul of shafts..... | 51 |

Function description

General

G701 is a 6 speed manual gearbox. The gearbox has four shafts:

- Input shaft
- Mainshaft
- Countershaft
- Reverse gear shaft

All the gear wheels in the gearbox are bevel cut except for the 1st gear wheel and the reverse gear wheel, which are straight cut. The mainshaft and reverse shaft gear wheels run on needle bearings. These gear wheels are in constant mesh with the countershaft gear wheels.

The shafts and the bearings are splash lubricated by means of oil pockets.

There are four selector forks within the gearbox cover with the following distribution:

- Reverse gear
- Gears 1 and 2
- Gears 3 and 4
- Gears 5 and 6

Input shaft

The input shaft with gear wheels is in one piece. In the front end of the gearbox housing the shaft is seated in a parallel roller bearing. The mainshaft and the countershaft teeth are bevel cut in opposite directions, reducing axial forces.

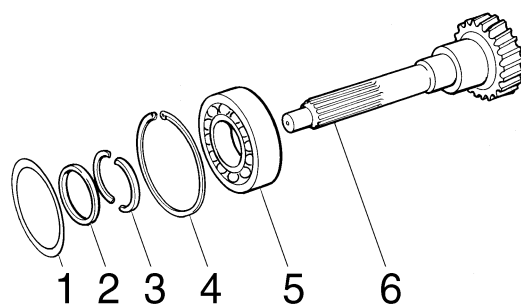

- 1 Shim
- 2 Retaining ring
- 3 Split ring
- 4 Retaining ring
- 5 Bearing
- 6 Input shaft

Mainshaft

The front end of the mainshaft is seated in a parallel roller bearing in the input shaft. The rear end of the mainshaft is seated in a parallel roller bearing in the rear end of the gearbox housing. The synchromeshes are seated on splined drivers.

The gear wheels are fitted with coupling teeth and can be engaged with the mainshaft by means of the synchromesh units. The gear wheels are seated on needle bearings on the mainshaft.

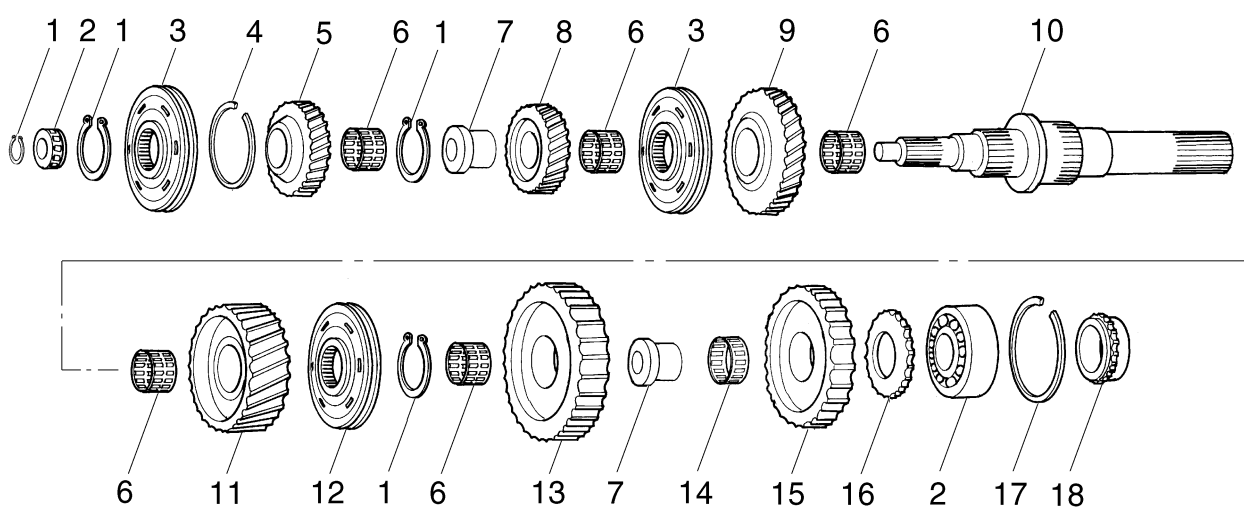

- 1 Retaining ring
- 2 Roller bearing
- 3 Single synchromesh
- 4 Retaining ring
- 5 5th gear wheel
- 6 Double-row needle bearing
- 7 Bushing
- 8 4th gear wheel
- 9 3rd gear wheel
- 10 Mainshaft
- 11 2nd gear wheel
- 12 Double synchromesh
- 13 1st gear wheel
- 14 Single-row needle bearing
- 15 Reverse gear wheel
- 16 Synchromesh disc
- 17 Retaining ring
- 18 Pulse wheel

b106582

Countershaft

The countershaft with the gear wheels for the reverse gear, 1st gear and 2nd gear is in one piece. The remaining gear wheels are press fitted on the countershaft without keys. The front and rear ends of the countershaft are seated in taper roller bearings in the gearbox housing.

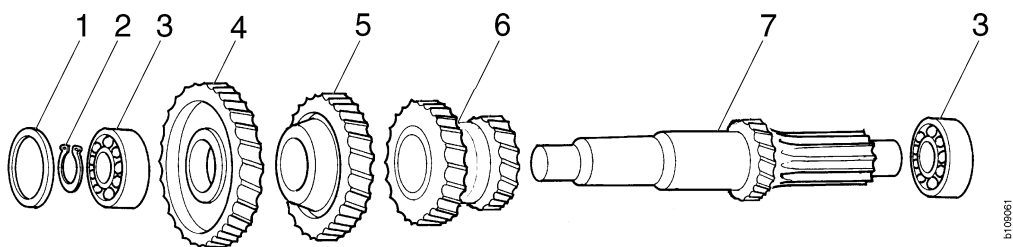

- 1 Shim
- 2 Retaining ring
- 3 Bearing
- 4 6th gear wheel
- 5 5th gear wheel
- 6 3rd and 4th gear wheels
- 7 Countershaft

Reverse gear shaft

The reverse gear shaft is seated in a bracket in the gearbox housing and in the gearbox rear end. The reverse gear wheels are seated on needle bearings on the reverse gear shaft.

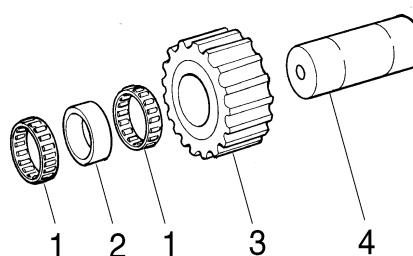

b1 009059

- 1 Needle bearing
- 2 Bushing
- 3 Reverse gear wheel
- 4 Reverse gear shaft

Synchromesh

The gearbox is fitted with synchromeshes to:

- Gears 1 and 2
- Gears 3 and 4
- Gears 5 and 6

The reverse gear has no synchromesh and thus only has one shift sleeve, engaging directly with the coupling teeth on the respective gear wheel when shifting into reverse. The 1st and 2nd gears have double synchromesh.

The purpose of the synchromesh is to rapidly bring the gear wheel for the gear concerned to the same speed as that of the mainshaft.

Single synchronesh, gears 3, 4, 5 and 6

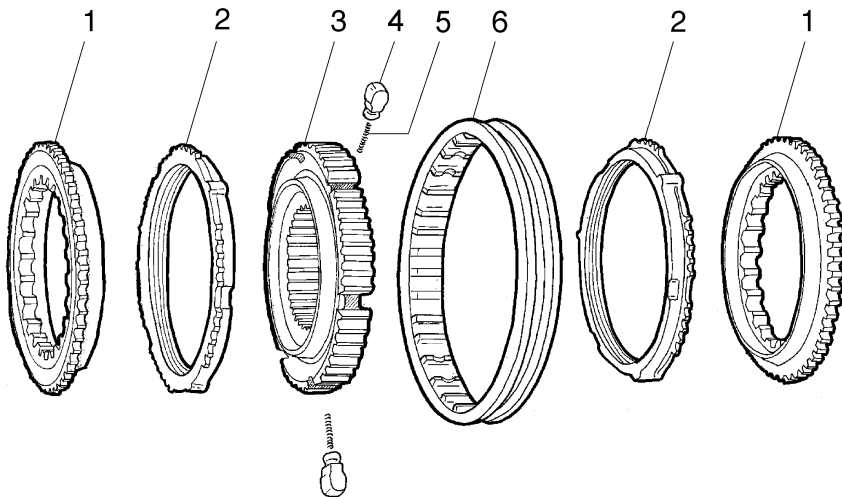

- 1 Synchronesh disc
- 2 Latch cone
- 3 Driver
- 4 Plunger
- 5 Spring
- 6 Shift sleeve

Double synchronesh, gears 1 and 2

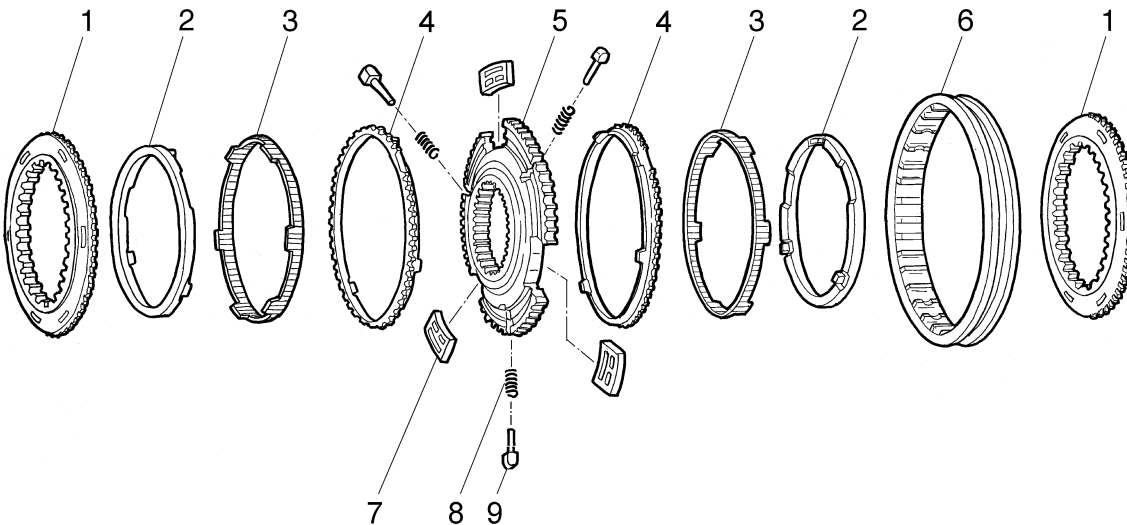

- 1 Synchronesh disc
- 2 Inner cone
- 3 Intermediate cone
- 4 Latch cone
- 5 Driver
- 6 Shift sleeve
- 7 Latch plate
- 8 Spring
- 9 Plunger

Controls

Gear changing is performed by means of a gear lever connected by cables to two control arms on the gearbox. Control arm 1, for side travel, changes between the different selector forks and control arm 2, for longitudinal travel, controls the forward and backward movement of the selector forks. The selector forks, in turn, change gear by moving the synchronesh units.

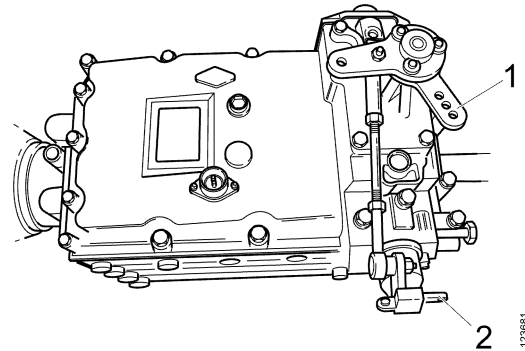

- 1 Control arm for side travel
- 2 Control arm for longitudinal travel

General diagram

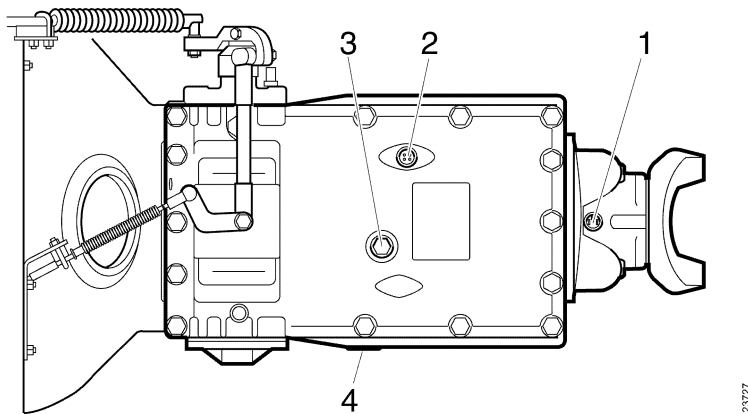

- 1 Speedometer sensor
- 2 Reversing light switch
- 3 Oil level plug
- 4 Drain plug for gearbox oil

Work description

General

Modifying the gearbox fixture

The pattern of holes in gearbox fixture 98 261 must be changed so that the fixture will fit G701. Drill four new holes as shown in the illustration.

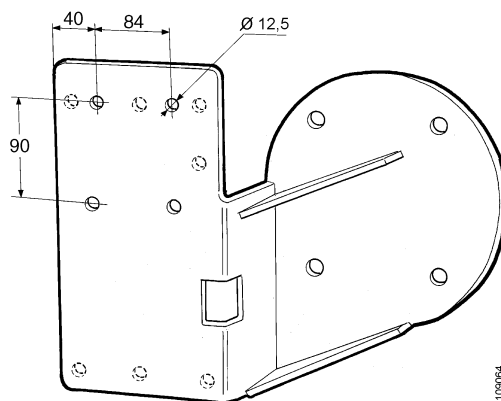

Orientations

Orientations as stated in this description refer to this illustration. Forward in the description refers to the input shaft end.

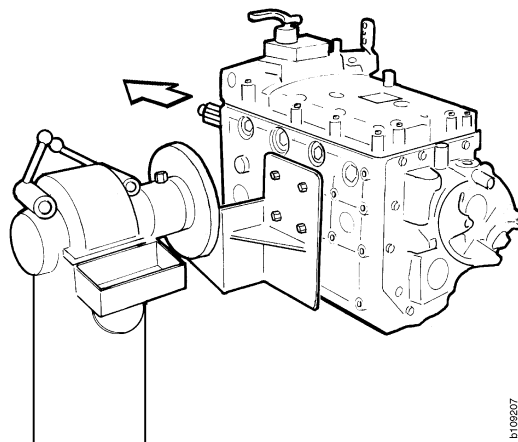













Spot repairs

Specifications

Tightening torque

| | |
|-----------------------|-------|
| Bolts, end yoke plate | 60 Nm |
|-----------------------|-------|

Special tools

| Number | Description | Illustration | Tool board |
|--------|--------------------------|---|--------------|
| 82 303 | Adapter |  | |
| 87 550 | Mandrel |  | AD2 |
| 98 257 | Mandrel |  | AM2, G2 |
| 98 450 | Shank |  | R2, AD2, AM1 |
| 98 743 | Assembly tool |  | C1 |
| 99 003 | Hydraulic cylinder |  | H1 |
| 99 004 | Pneumatic hydraulic pump |  | H1 |
| 99 012 | Fully threaded spindle |  | H1 |
| 99 040 | Pusher adapter |  | H1 |
| 99 124 | Puller |  | AM1 |
| 99 127 | Mandrel |  | AM1 |
| 99 160 | Mandrel |  | |

Renewing the output shaft seal

- 1 Remove the striker plate, bolts and end yoke plate.
- 2 Remove the end yoke with puller 99 124 and drift 98 257.
- 3 Renew the seal in the rear cover. Use drifts 87 550 and 99 127 to tap in the new seal.
- 4 Grease the rear cover seal.
- 5 Press on the end yoke using tools 82 303, 99 040, 99 012, 98 743, 99 003, and 99 004.

Tightening torque

| | |
|-----------------------|-------|
| Bolts, end yoke plate | 60 Nm |
|-----------------------|-------|

- 6 Fit the end yoke plate and tighten the bolts.
- 7 Tap in the striker plate with drift 99 160 and shank 98 450.

Renew the link between the control arms

- 1 The setting dimension should be 85 - 87 mm between the lock nuts on the link.

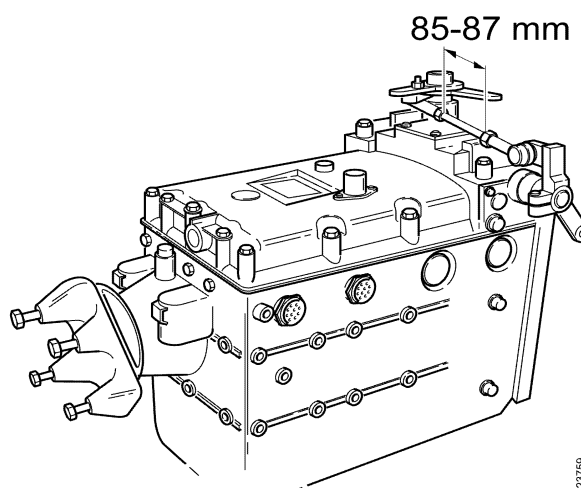

123759

Overhaul of selector housing

Selector housing

- 1 Clamp the selector housing in a vice with soft jaws.
- 2 Remove the reverse gear inhibitor. Mark the control arm with two punch marks and remove it.

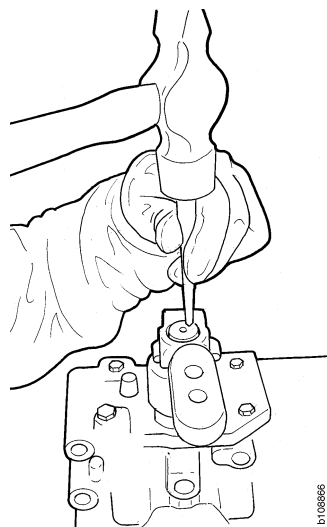

- 3 Remove the right-hand side cover.
- 4 Remove the upper cover.

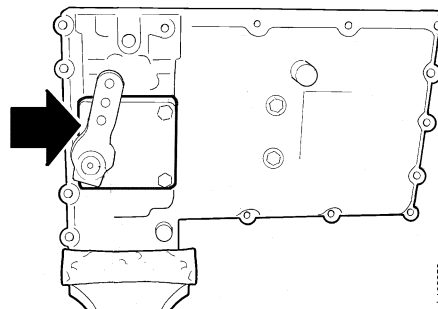

Note: The left-hand side cover is spring-loaded.

- 5 Tilt the selector housing and remove the left-hand side cover.
- 6 Remove the springs and the plunger.

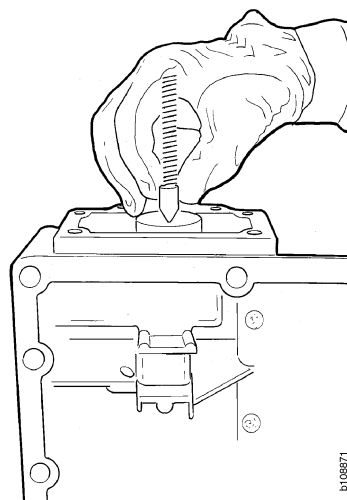

Note: The spring is under load.

- 7 Remove the retaining ring, the spring and the washers.

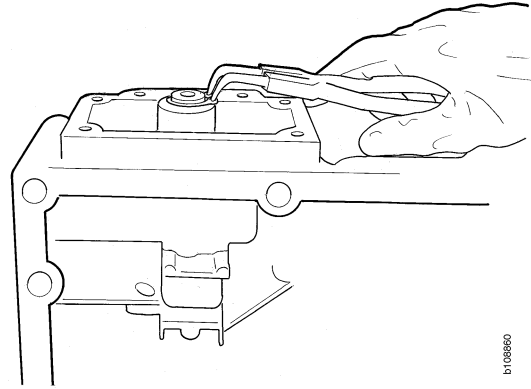

- 8 Tap out the needle pin.

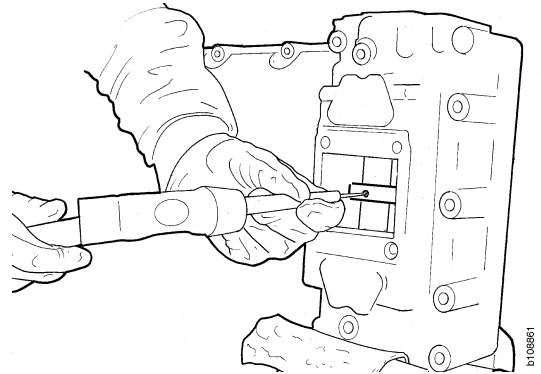

- 9 Remove the small shaft.

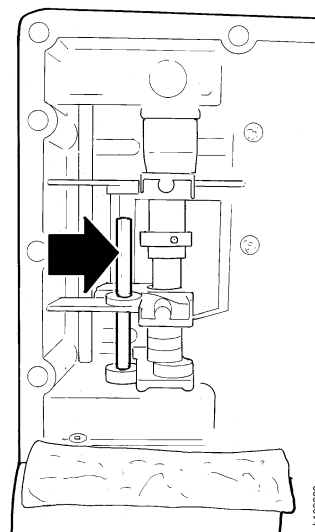

Note: Mark up the position and location of the parts.

10 Pull out the gear selector shaft.

11 Remove the loose parts.

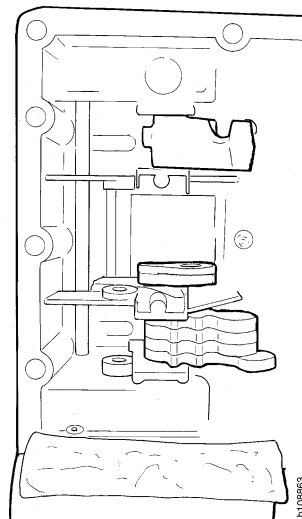

12 Tap out the bushing using a suitable sleeve.

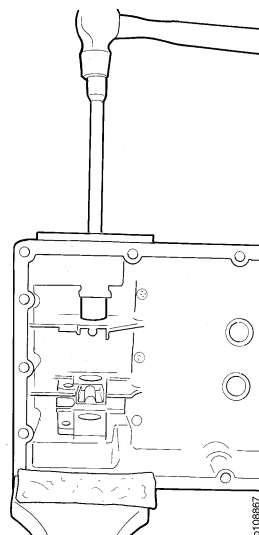

13 Tap out the bearing using the same sleeve.

14 Renew the bearing, bushing and gaskets.

15 Assemble in reverse order.

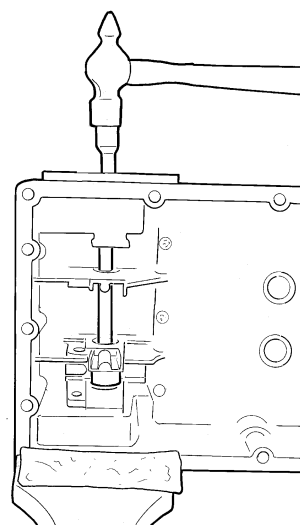

Left-hand side cover

Renew the seal using a suitable sleeve.

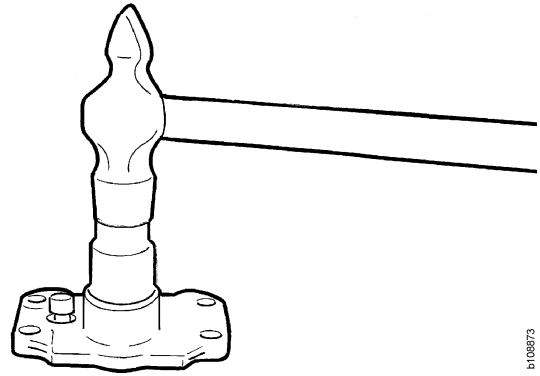

b108873

Removal and fitting of gearbox

Removal

Specifications



Tightening torque

| | |
|---------------------------------------|-----------------------|
| Propeller shaft bearing cap, end yoke | 105 Nm |
| Castle nut, track rod ball joint | 250 Nm + to next hole |
| Gearbox to flywheel housing | 47 Nm |



Consumables

| | |
|-------------|---------------------------|
| Brake fluid | Refer to booklet 00:03-09 |
|-------------|---------------------------|

Special tools

| Number | Description | Illustration | Tool board |
|----------|----------------------------------|---|------------|
| 82 320 | Support plate |  | |
| 98 405-2 | Fixture bracket (part of 98 400) | | F1, F2 |
| 98 655 | Fixture beam (part of 98 400) | | F2 |
| 99 309 | Turning tool |  | D5 |

Other tools

| Number | Description | Illustration | Tool board |
|---------------|---------------------|--|-------------------|
| 587 313 | Gearbox jack |  | |
| 587 500 | Component hoist |  | |
| 587 949 | Clutch bleeder unit |  | |

Working from above

- 1 Cut the voltage by detaching the minus cable from the battery.
- 2 Remove the cover in the floor above the gearbox.
- 3 Detach the cables from the attachments on the control arms.

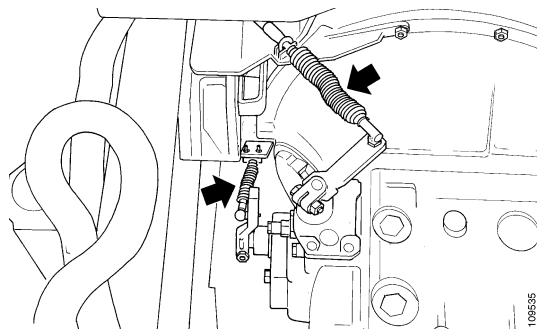

- 4 Remove the four clutch housing upper nuts. Also remove the plastic cover for the inspection hole.

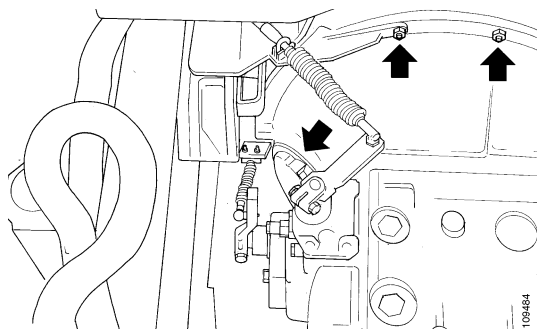

Working from below

- 1 Remove the oil plug and drain the gearbox oil.

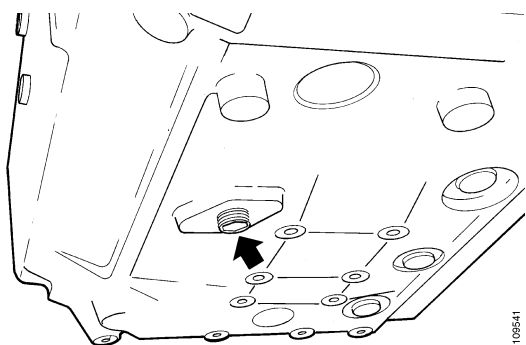

- 2 Detach the exhaust pipe from the flexible joint at the engine and the joint forward of the compressed-air tanks.
- 3 Remove the yoke below the propeller shaft.

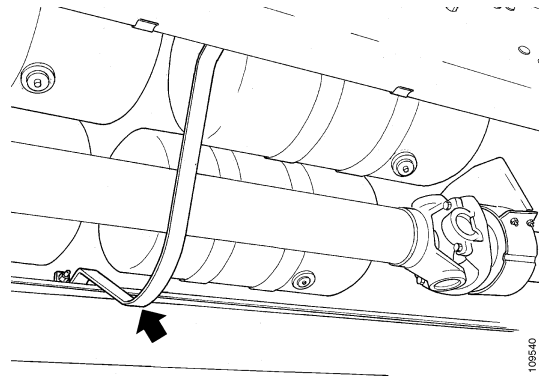

- 4 Removal of propeller shaft front section:
 - Detach the propeller shaft from the gearbox.
 - Detach the support bearing bracket from the frame crossmember and remove the propeller shaft front section.
 - Leave the rear section in place.
- 5 Detach the track rod from one steering arm and move it to one side.
- 6 Detach the electrical connection to the reversing light switch.
- 7 Cut the speedometer cable seal and detach the cable.

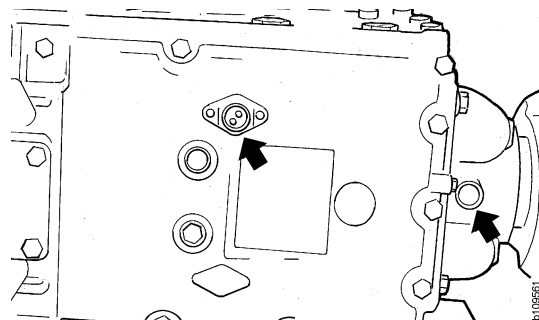

- Using turning tool 99 309, rotate the flywheel so that the wire ends of the slave cylinder retaining ring face the inspection hole.



WARNING!

Wear protective goggles. Hydraulic fluid is corrosive and can cause permanent eye damage.

- Detach the clutch servo hose from the slave cylinder. Make sure that dirt does not penetrate into the hydraulic system.
- Plug the clutch servo hose and slave cylinder so that hydraulic fluid does not run out.

Note: Do not squeeze the clutch servo hose. It may cause permanent damage.

- Position gearbox jack 587 313 with fixture bracket 98 405-2, fixture beam 98 655 and support plate 82 320 below the gearbox. If there is enough space under the vehicle, use component hoist 587 500 instead of the gearbox jack.
- Fit a strap around the gearbox and the support plate.
- Remove the remaining clutch housing lower nuts.

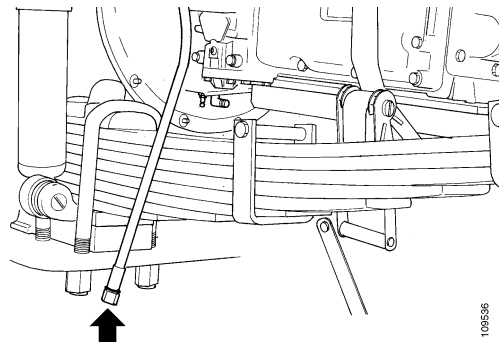

109536

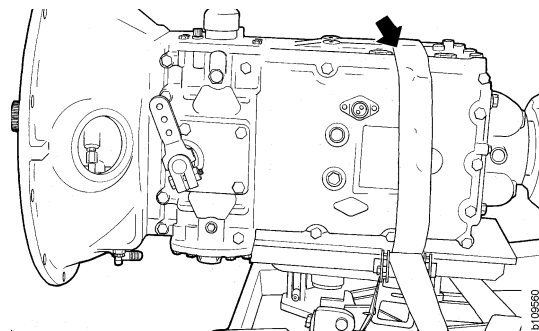

5109500

To make it easier to compress the retaining ring, the return spring pressure on the slave cylinder should be relieved so that the retaining ring does not press against the puller ring. Proceed as follows:

Note: If the retaining ring has broken, the gearbox cannot be removed unless the bolts fastening the slave cylinder to the gearbox are also removed.

Note: The illustrations show gearbox GR900, but the principle is the same for G701.

- 14 Detach the plug from the slave cylinder.
- 15 Pull the gearbox backwards 10-15 mm.
- 16 Plug the slave cylinder.

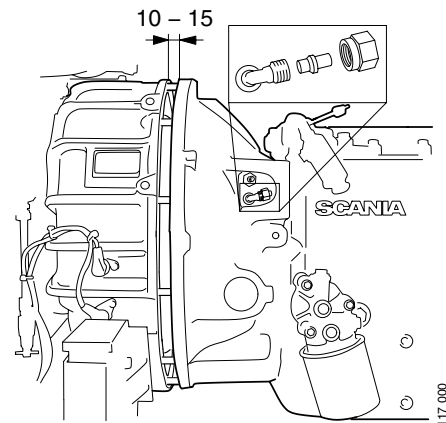

- 17 Carefully push the gearbox back towards the clutch flange, so that the retaining ring is relieved.

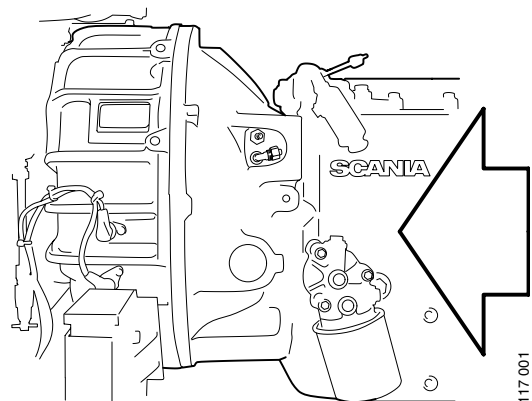

- 18 Compress the retaining ring wire ends until the slave cylinder is released from the diaphragm spring joint. Use polygrip pliers.

Instead of using pliers to hold the retaining ring wire ends together, a flattened pipe, approx. 15 mm diameter or a strap can be used.

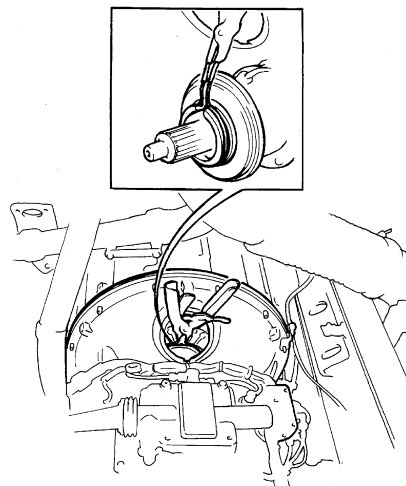

- 19 Lower the gearbox and pull it out. Make sure that the gearbox goes clear of any obstructions.

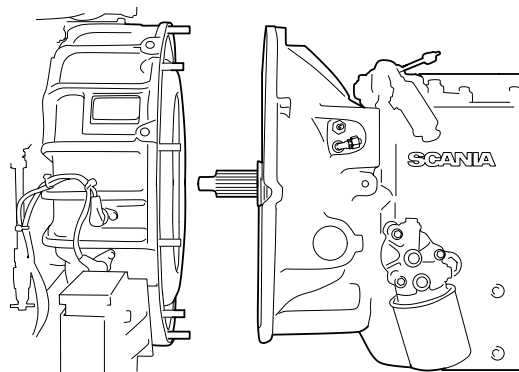

Fitting

Working from below

- 1 Position the gear box on support plate 82 320, use gearbox jack 587 313, fixture bracket 98 405-2 and fixture beam 98 655. If there is enough space under the vehicle, use component hoist 587 500 instead of the gearbox jack.
- 2 Secure the gearbox with a strap.

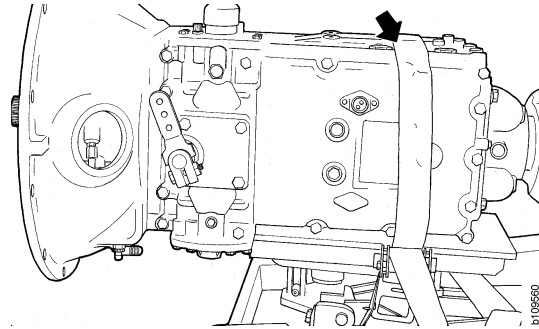

- 3 Engage a gear.
- 4 Oil the spring pins with anticorrosive oil.
- 5 Push the slave cylinder into position (aligning spring pin with rear edge of shoulder) using large polygrip pliers. Fit a retaining ring and ensure that it is correctly seated.

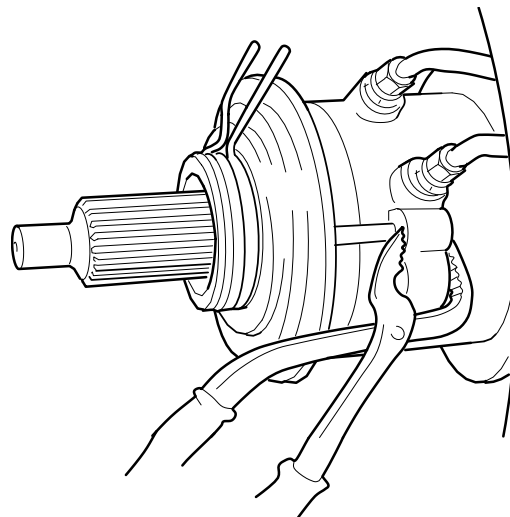

IMPORTANT! Fit a new retaining ring.

- 6 Check that the puller ring and its securing ring are correctly seated.
- 7 Align the gearbox and push it into position. When the slave cylinder engages with the diaphragm spring locking device an audible click can be heard. Check that the slave cylinder has engaged by trying to pull the gearbox rearwards.

Note: It is important to align the gearbox vertically and horizontally to prevent misalignment of the slave cylinder in the diaphragm spring joint.

Note: Do not compress the retaining ring wire ends after fitting. The slave cylinder may snap loose from the diaphragm spring joint.

- 8 Fasten the gearbox in the clutch housing using the nuts which can be accessed from below.

Tightening torque

| | |
|----------------------|-------|
| Nuts, clutch housing | 47 Nm |
|----------------------|-------|

- 9 Remove the strap from the gearbox and support plate 82 320. Remove the gearbox jack 587 313 and fixtures.
- 10 Fit the speedometer cable and seal it.
- 11 Fit the gearbox electrical connection.
- 12 Fit the clutch servo hose.
- 13 Fit the propeller shaft front section. Turn the propeller shaft sections so that all grease nipples face the same direction.

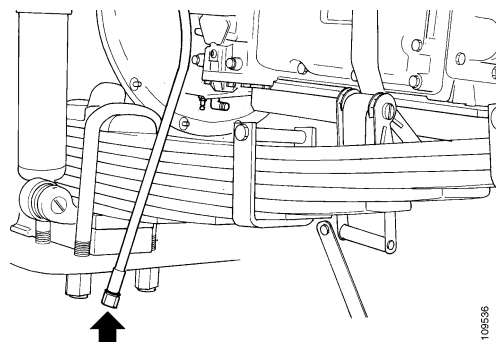

Tightening torque

| | |
|--------------------|--------|
| Bolts, bearing cap | 105 Nm |
|--------------------|--------|

- 14 Fit the yoke below the propeller shaft.
- 15 Fit the track rod to the steering arm. Tighten the nut to 250 Nm and then to the closest slot.

Tightening torque

| | |
|-------------------------------------|--------|
| Nuts, track rod on the steering arm | 250 Nm |
|-------------------------------------|--------|

- 16 Fit the exhaust pipe to the flexible joint at the engine and the joint forward of the compressed-air tanks.

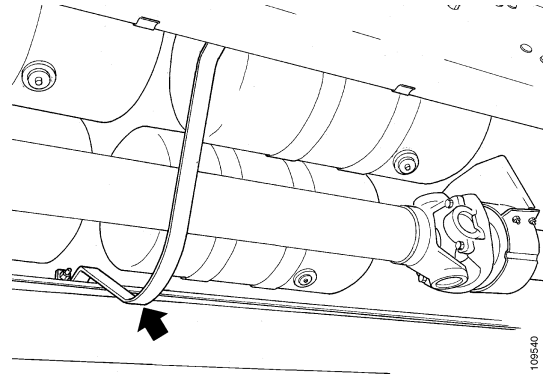

Working from above

- 1 Fit the cables to the control arms on the gearbox.
- 2 Fit the remaining clutch housing upper nuts.

Tightening torque

| | |
|----------------------|-------|
| Nuts, clutch housing | 47 Nm |
|----------------------|-------|

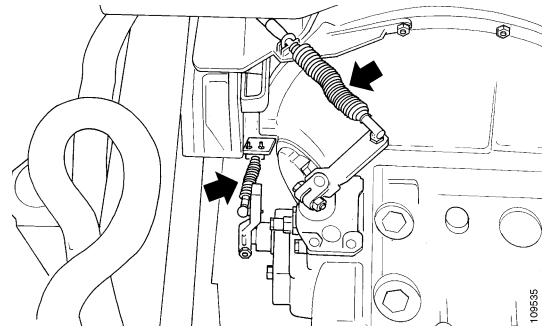

- 3 Check that the slave cylinder locking ring can be turned by hand.

Note: Do not compress the retaining ring wire ends.

- 4 Fit the plastic cover for the inspection hole in the clutch housing.
- 5 Remove the plug on the upper side of the gearbox and the oil level plug on the side and top up with gearbox oil.
- 6 Top up the brake fluid and bleed the clutch system. Use tool 587 949.

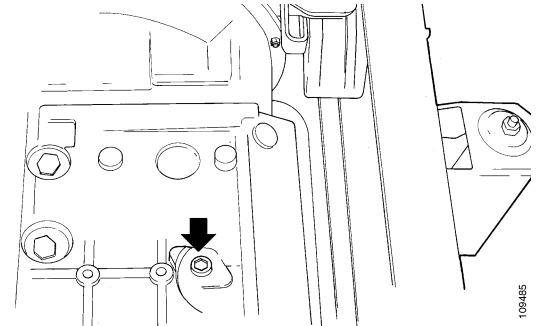

Specifications

| | |
|-------------|------------------------------|
| Brake fluid | Refer to booklet 00:03-09 |
|-------------|------------------------------|

- 7 Fit the cover in the floor above the gearbox.

Overhaul of gearbox

Dismantling

A locking tool is required to lock the countershaft bearing race. This can easily be manufactured from a piece of flat iron as shown in the diagram.

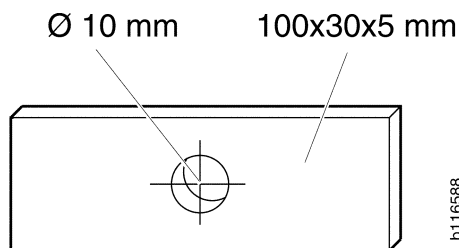

Locking tool for countershaft bearing race, manufactured locally.

- 1 Attach the gearbox to a universal stand with gearbox fixture 98 261. Drain the remaining gearbox oil.
- 2 Detach the gearbox cover. Remove the locating bolts for the selector forks.

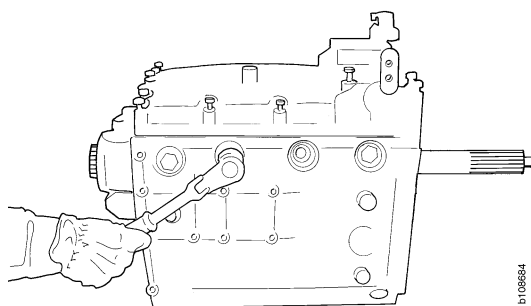

- 3 Lift the gearbox cover at the rear and detach the selector plates.
- 4 Remove the gearbox cover.

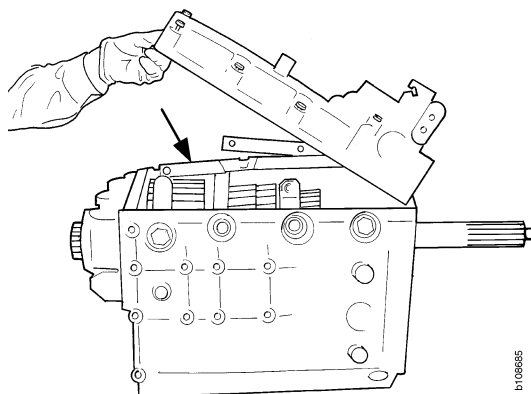

- 5 Remove the selector forks. Push the reverse gear wheel backwards to release the rear selector fork.

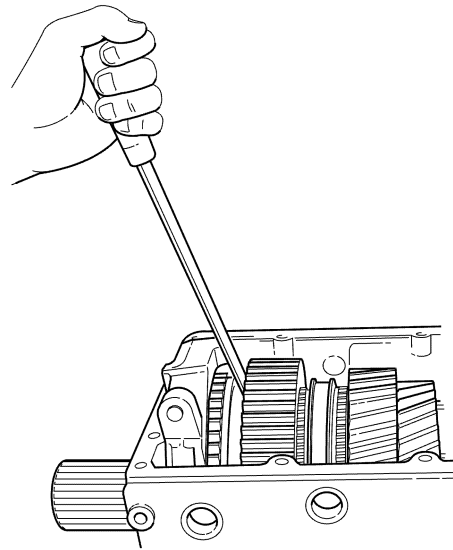

123729

- 6 Tilt the gearbox.
- 7 Remove the end yoke plate.
- 8 Remove the end yoke using puller 99 124 and drift 98 257.
- 9 Remove the speedometer sensor.
- 10 Remove the rear cover and the gasket.

Note: There are loose shims in the rear cover.

- 11 Remove the bearing retaining ring and remove the rear bearing using puller 587 428 and puller plate 82 343.

Note: Note the pulse wheel position on the shaft!

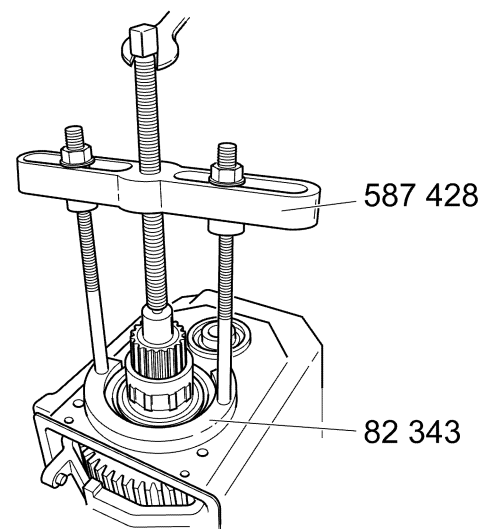

123726

- 12 Secure the countershaft rear bearing race with a locally manufactured locking tool.

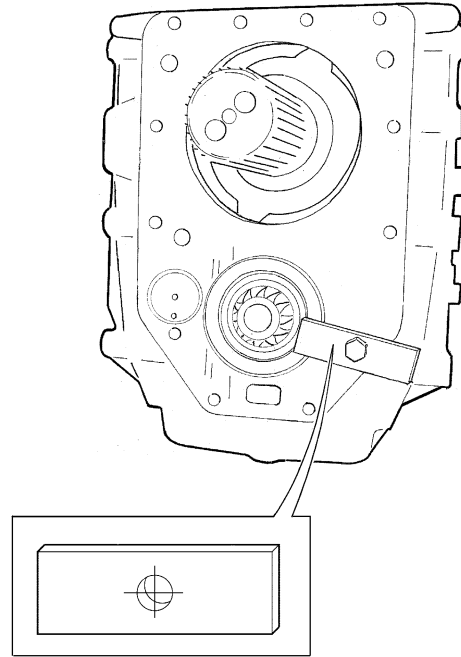

123760

- 13 Place something between the gearbox housing and lowest gear wheel (approx. 10 mm), e.g. two screwdrivers.

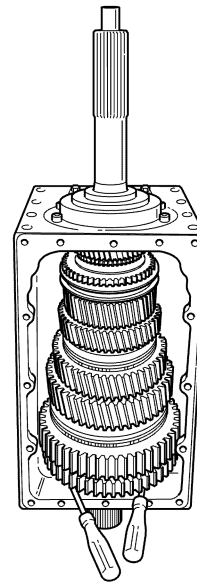

123741

- 14 Tilt the gearbox and remove the two front covers.

Note: There are loose shims in both covers.

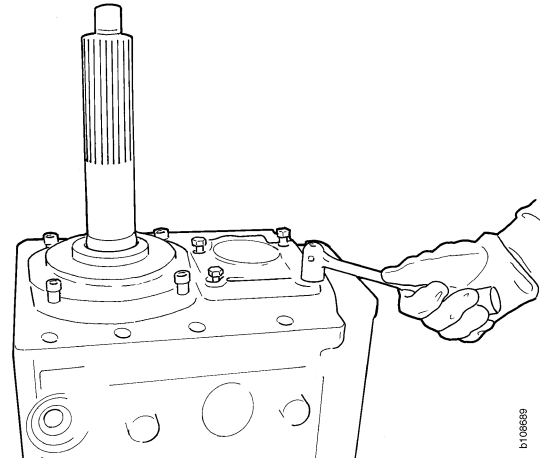

- 15 Split the retaining ring and remove it. Then remove the split ring.

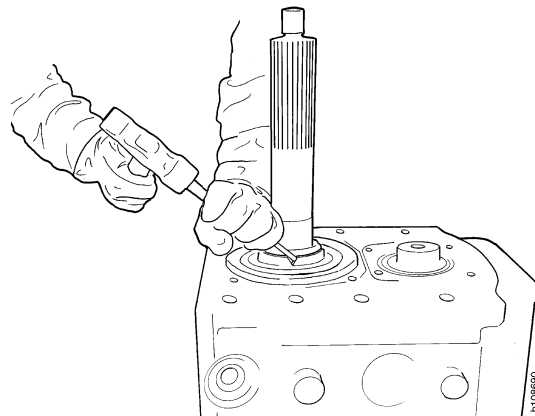

- 16 Remove the bearing retaining ring. Remove the front bearing using puller 587 428 and puller plate 82 343.

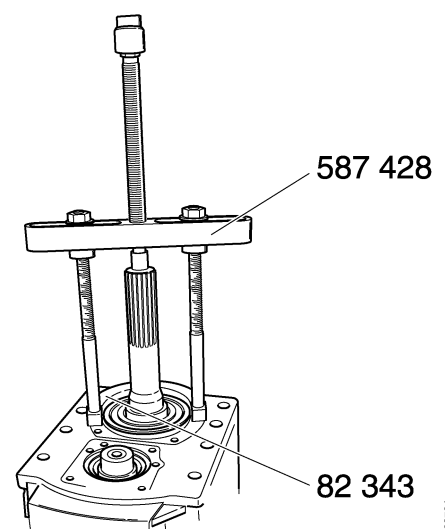

17 Lift out the input shaft.

Note: Make sure that the synchromesh is not removed with it.

18 Tilt the gearbox into a horizontal position and remove the spacers.

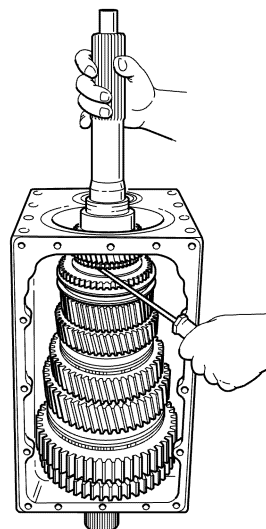

123728

19 Remove the loose parts of the synchromesh unit.

20 Lift out the mainshaft using a lifting sling. Attach the sling behind the reverse gear wheel and around the 5th gear wheel. Tilt the gearbox and lift out the mainshaft at the same time.

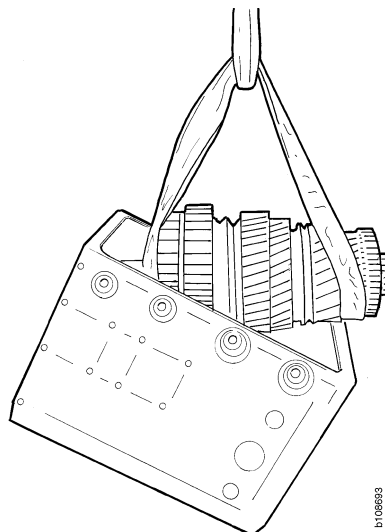

b106893

- 21 Detach the locking tool which locks the countershaft rear bearing race and tap it out.



WARNING!

Use protective goggles since there may be sparks.

- 22 Tap out the reverse gear shaft.

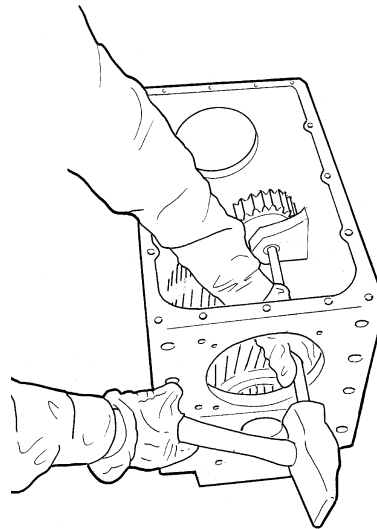

b1108694

- 23 Remove the reverse gear wheel and bearing.

- 24 Lift out the countershaft using a lifting sling.

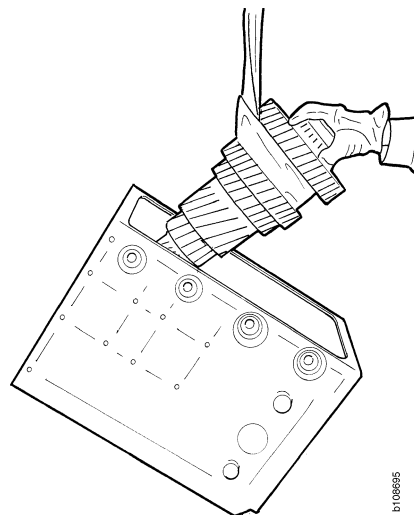

b1108695

- 25 Tap out the countershaft front bearing race.

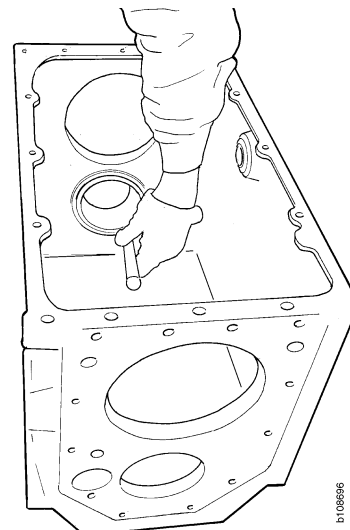

b1108696

Assembly

Specifications















Axial clearance





| | |
|-----------------------------------|----------------|
| Mainshaft | Max 0.10 mm |
| Countershaft | 0.10 - 0.25 mm |
| Between mainshaft and input shaft | 0.40 - 0.70 mm |
| Input shaft and cover | Max 0.10 mm |

Tightening torque

| | |
|----------------------------------|--------|
| Bolts, rear cover | 49 Nm |
| Bolts, front cover, countershaft | 60 Nm |
| Bolts, front cover, input shaft | 49 Nm |
| Bolts, gearbox cover | 49 Nm |
| Locating bolts | 220 Nm |
| Oil plug | 50 Nm |
| End yoke bolts | 60 Nm |

Special tools

| Number | Description | Illustration | Tool board |
|---------------|--------------------------|---|-------------------|
| 82 303 | Adapter |  | |
| 82 343 | Extractor plate |  | |
| 87 294 | Mandrel |  | AD/AS3, G3 |
| 87 504 | Mandrel |  | |
| 87 550 | Mandrel |  | AD2 |
| 87 932 | Mandrel |  | D3, G1 |
| 98 257 | Mandrel |  | AM2, G2 |
| 98 261 | Gearbox fixture |  | A |
| 98 450 | Shank |  | R2, AD2, AM1 |
| 98 743 | Assembly tool |  | C1 |
| 99 003 | Hydraulic cylinder |  | H1 |
| 99 004 | Pneumatic hydraulic pump |  | H1 |
| 99 012 | Fully threaded spindle |  | H1 |
| 99 040 | Pusher adapter |  | H1 |

| Number | Description | Illustration | Tool board |
|--------|-------------|---|------------|
| 99 124 | Puller |  | G1, H1 |
| 99 127 | Mandrel |  | AM1 |
| 99 160 | Mandrel |  | |
| 99 190 | Mandrel |  | G4 |

Other tools

| Number | Description | Illustration | Tool board |
|---------|-------------|---|------------|
| 587 428 | Puller |  | |

Fitting the countershaft

- 1 Tap in the countershaft front bearing race with drift 87 932 so that the bearing race is flush with the gearbox housing.

Note: The front bearing race is thinner than the rear bearing race.

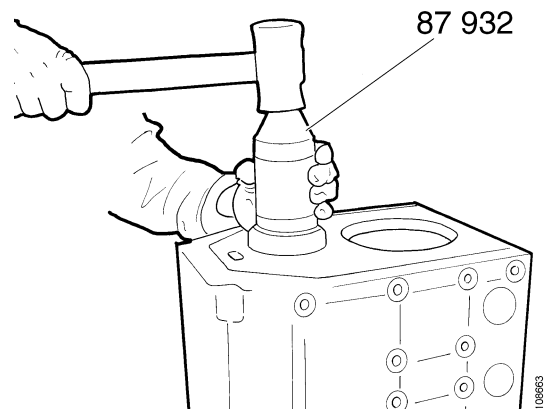

- 2 Bring the countershaft into the gearbox using a lifting sling.
- 3 Use drift 87 932 and tap in the countershaft rear bearing race so that it protrudes 10 mm outside the gearbox housing. Rotate the shaft while tapping.
- 4 Secure the bearing race using the locally manufactured locking tool used at dismantling.

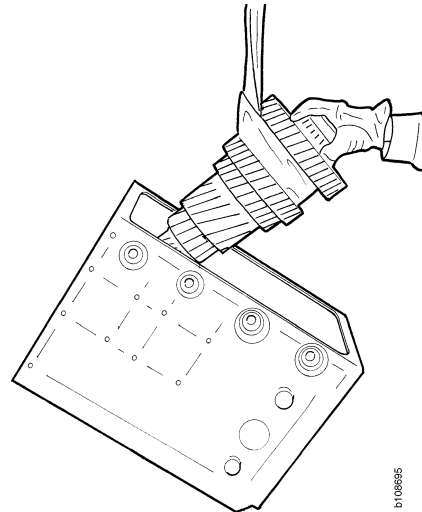

Fitting the reverse gear shaft

- 1 Fit the reverse gear wheel and bearing. Tap in the shaft.

Note: The reverse gear wheel flange must face rearwards.

- 2 Check that the reverse gear wheel spins easily.

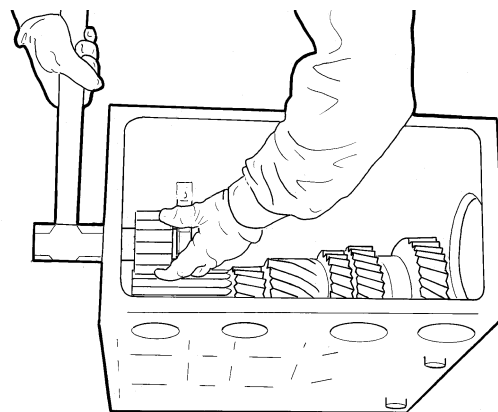

Fitting the mainshaft

- 1 Bring the mainshaft into the gearbox using a lifting sling.

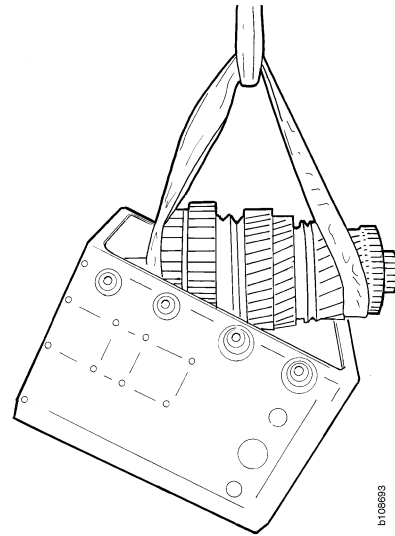

- 2 Hold up the mainshaft using an iron wire and fit the 5th gear/6th gear synchromesh.

Note: Make sure that the plungers are fitted with the rounded portion along the shaft.

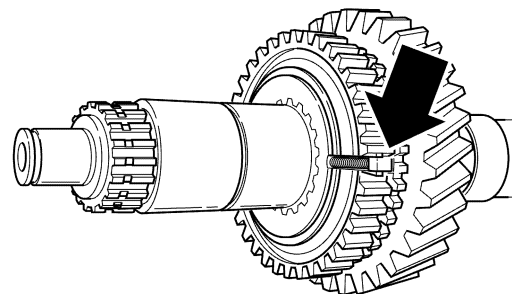
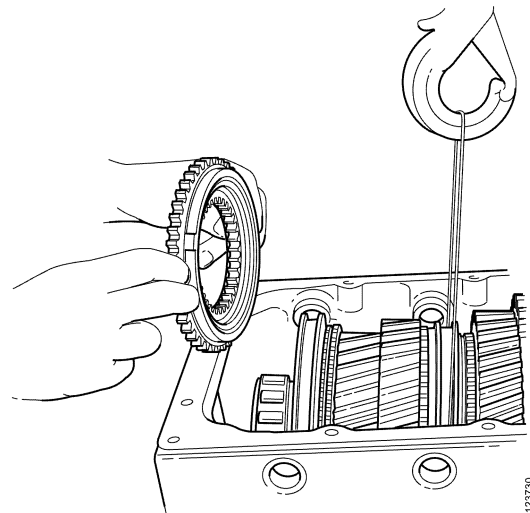

Make sure that the plungers are fitted with the rounded portion along the shaft.

- 3 Fit the input shaft in the gearbox.

Note: The splines on the input shaft must engage with the synchromesh disc.

- 4 Fit the retaining ring on the input shaft bearing and tap the bearing into the gearbox housing.
- 5 Tilt the gearbox so that the output shaft is facing upwards.
- 6 Fit the retaining ring on the mainshaft rear bearing.

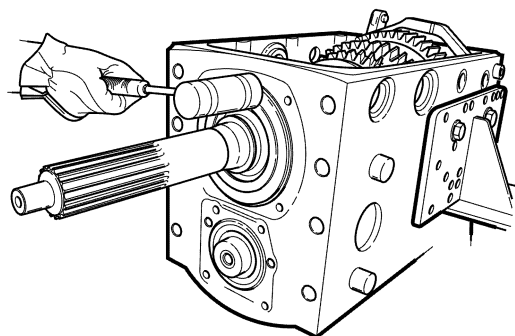

Note: The groove in the bearing must face outwards.

- 7 Tap on the rear bearing. The retaining ring must face outwards.

- 8 Measure the mainshaft axial clearance. With the gasket fitted, measure dimension A. Measure from the gasket to the bearing contact surface in the cover, e.g. 8.8 mm.

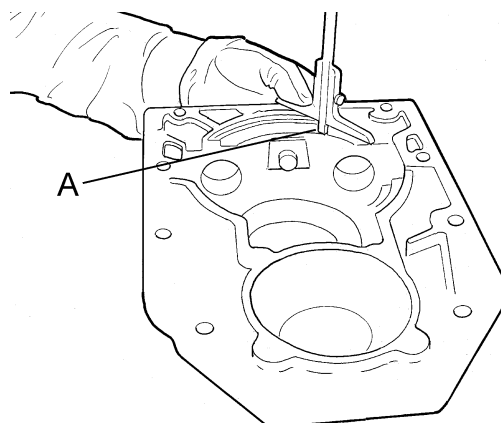

- 9 Measure the amount the bearing face protrudes from the gearbox housing, dimension B, e.g. 7.6 mm.
- 10 Shim thickness = A - B, e.g. 8.8 - 7.6 = 1.2 mm. Fit a shim which leaves as little axial clearance as possible, max 0.10 mm.

Axial clearance

| | |
|-----------|-------------|
| Mainshaft | Max 0.10 mm |
|-----------|-------------|

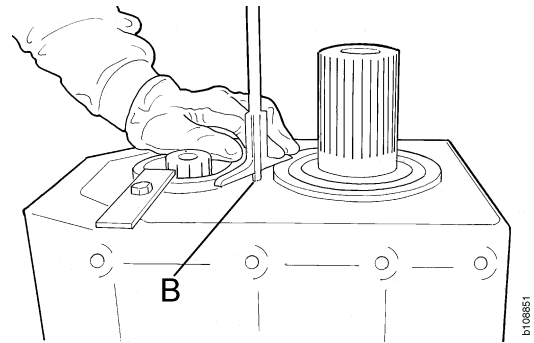

- 11 Remove the countershaft locking tool.

Note: The shortest flange on the pulse wheel must face towards the gearbox.

- 12 Heat the pulse wheel to 100°C and fit it on the output shaft.

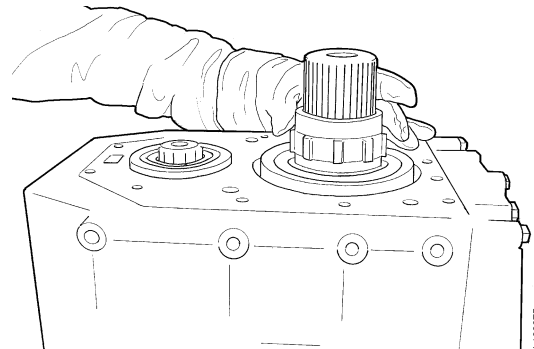

- 13 Fit a new seal in the rear cover using drifts 87 550 and 99 127. The seal can also be renewed with these tools with the gearbox fitted in the vehicle.

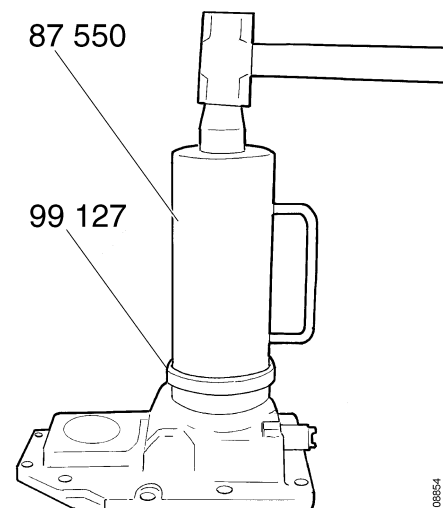

- 14 Fit the rear cover, shim and gasket and tighten bolts to 49 Nm.

Tightening torque

| | |
|-------------------|-------|
| Bolts, rear cover | 49 Nm |
|-------------------|-------|

- 15 Fit the speedometer sensor in the rear cover.
- 16 Turn the gearbox so that the input shaft is facing upwards.
- 17 Tap in the countershaft bearing at the bottom. Rotate the shaft at the same time.
- 18 Measure the countershaft axial clearance.
With the gasket fitted, measure the countershaft bearing race depth. Use a shim which leaves an axial clearance of 0.10 - 0.25 mm.

Axial clearance

| | |
|--------------|----------------|
| Countershaft | 0.10 - 0.25 mm |
|--------------|----------------|

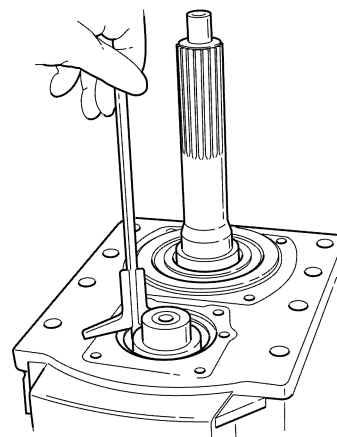

123776

- 19 Fit the front cover and tighten the bolts to 60 Nm.

Tightening torque

| | |
|--------------------|-------|
| Bolts, front cover | 60 Nm |
|--------------------|-------|

- 20 Remove the retaining ring from the input shaft bearing.
- 21 Remove the input shaft bearing. Use puller plate 82 343 and puller 587 428.
- 22 Lift out the input shaft.

Note: Make sure that the synchromesh does not slip off. Hold it down with a screwdriver.

- 23 Refit the input shaft bearing.

Note: The groove in the bearing must face outwards.

- 24 Tap the split ring on to the input shaft.
- 25 Fit a new retaining ring and upset it against the split ring.
- 26 Fit the retaining ring on the input shaft bearing.

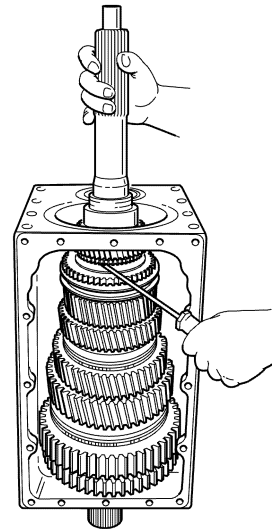

123728

- 27 Measure the axial clearance between the mainshaft and input shaft. Measure dimension A between the gearbox housing surface and synchromesh disc surface for the shim, e.g.: 71.2 mm.

Note: Carry out the measurement with the mainshaft vertical and without supporting or affecting the output shaft.

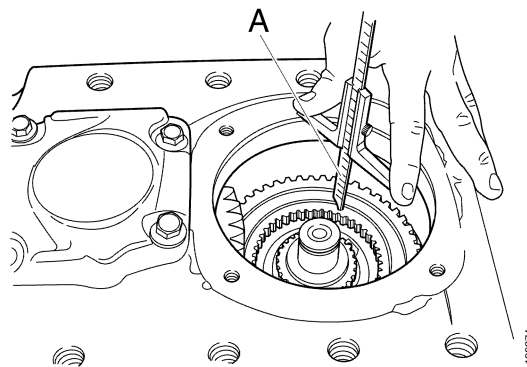

- 28 Measure dimension B on the input shaft between the bearing retaining ring and the machined contact surface for the shim, e.g. 67.0 mm.

Note: Press the retaining ring against the bearing at the measurement point to obtain the correct measurement.

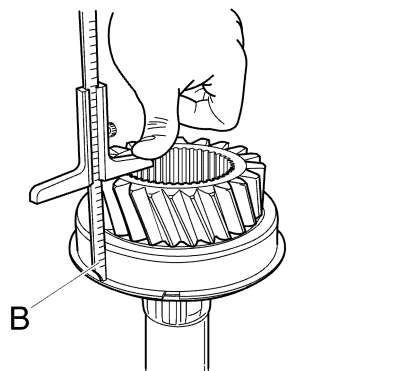

- 29 Calculate A - B. Use a shim which is 0.4 - 0.7 mm less than the calculated value, e.g.: 71.2 - 67.0 mm. 4.2 - 0.4 = 3.8 mm and 4.2 - 0.7 = 3.5 mm. The shim should therefore be between 3.5 mm and 3.8 mm thick in this example.

Axial clearance

| | |
|-----------------------------------|----------------|
| Between mainshaft and input shaft | 0.40 - 0.70 mm |
|-----------------------------------|----------------|

- 30 Tap the input shaft into the gearbox housing with a rubber mallet. Tap down the bearing in the bottom.

Note: The splines on the input shaft must engage with the synchromesh disc.

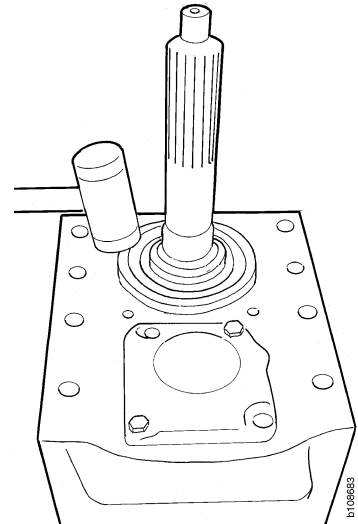

- 31 Measure the input shaft axial clearance.
With the gasket fitted, measure dimension D between the input shaft bearing race and the gasket.

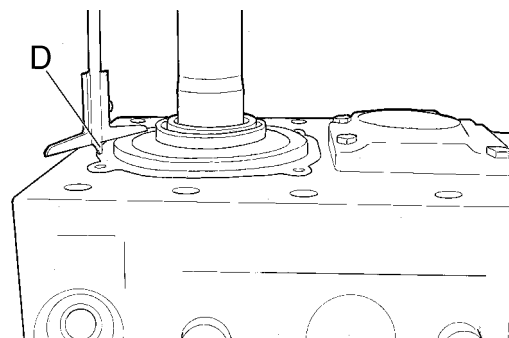

- 32 Measure dimension C in the cover between the gearbox housing contact surface and the bearing contact surface.

Axial clearance

| | |
|-------------|---------|
| Input shaft | 0.10 mm |
|-------------|---------|

- 33 Shim thickness = $C - D$. Use a shim which leaves as little clearance as possible.

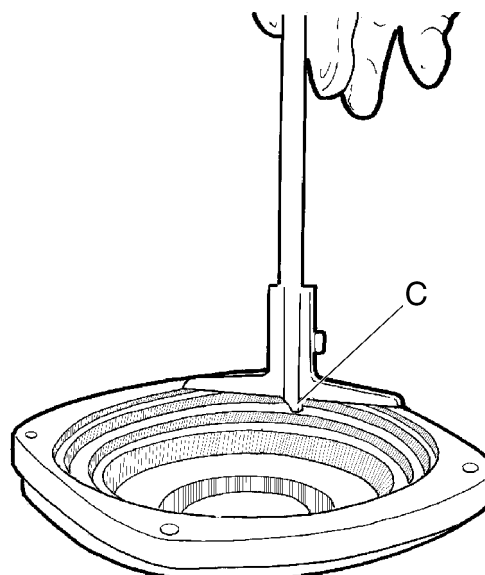

- 34 Fit a new seal in the front cover using drifts 87 504 and 99 190.
- 35 Fit the cover on the input shaft.
- 36 Tighten the bolts on the cover.

Tightening torque

| | |
|--------------------|-------|
| Bolts, front cover | 49 Nm |
|--------------------|-------|

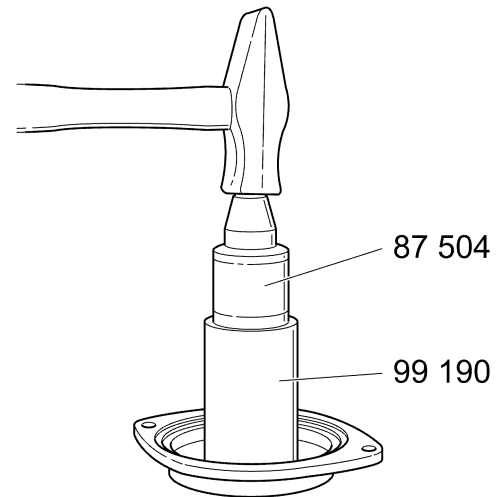

123740

Assembling the gearbox housing

- 1 Fit the selector forks and fit all locating bolts apart from the reverse gear selector fork.
- 2 Cement the gearbox housing gasket.
- 3 Fit the gearbox cover and hook in the selector plates.
- 4 Fit the locating bolts for the reverse gear selector fork.
- 5 Tighten all locating bolts.

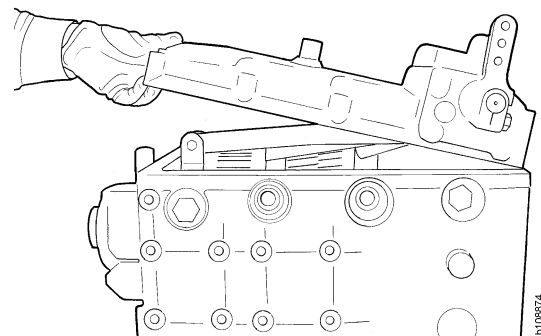

b119874

Tightening torque

| | |
|----------------|--------|
| Locating bolts | 220 Nm |
|----------------|--------|

- 6 Tighten the gearbox cover bolts.

Tightening torque

| | |
|---------------|-------|
| Gearbox cover | 49 Nm |
|---------------|-------|

- 7 Grease the rear cover seal. Press on the end yoke. Use tools 82 303, 99 040, 99 012, 98 743, 99 003, and 99 004.

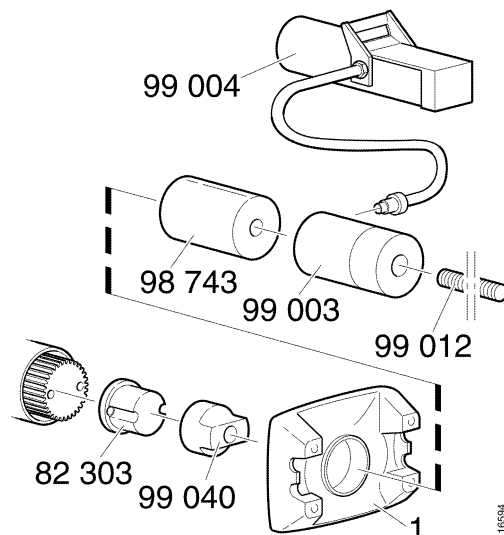

- 8 Fit the end yoke plate and tighten the bolts.

Tightening torque

| | |
|------------------------|-------|
| Bolts, end yoke plate. | 60 Nm |
|------------------------|-------|



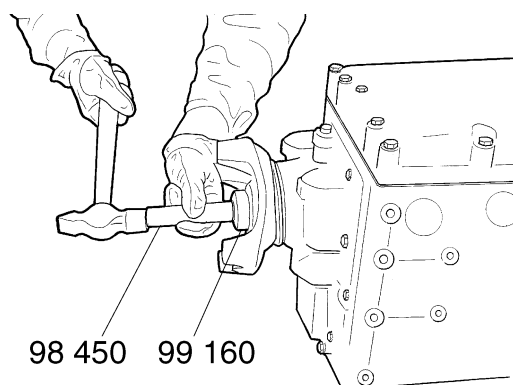

- 9 Fit the striker plate using drift 99 160 and shank 98 450.





Overhaul of shafts

Dismantling the mainshaft

Special tools

| Number | Description | Illustration | Tool board |
|--------|--------------|--|------------|
| 98 322 | Lifting eye |  | G2 |
| 99 136 | Hollow drift |  | |
| 99 139 | Support ring |  | |
| 99 154 | Mandrel |  | G2 |

Other tools

| Number | Description | Illustration | Tool board |
|---------|-------------|--|------------|
| 587 321 | Puller |  | |
| 587 438 | Puller |  | |
| 587 511 | Puller |  | |

- 1 Wind a lifting strap at least one turn under the reverse gear wheel, lock with a strap around the 5th gear wheel and lift up the mainshaft. Put it in hollow drift 99 136 and support ring 99 139.

Note: Use a strap with a locking feature.

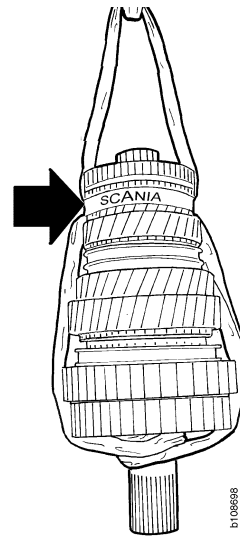

- 2 Remove the bearing retaining ring.
- 3 Remove the bearing using puller 587 511 and drift 99 154.

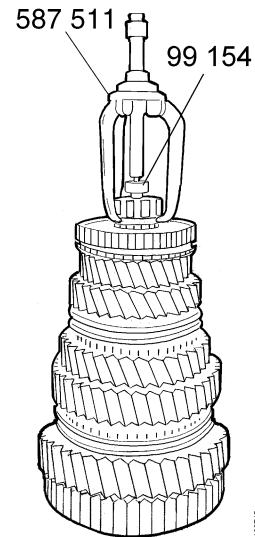

- 4 Remove the retaining ring for the 5th gear/6th gear synchromesh unit. Note the driver position on the mainshaft. Remove the synchromesh unit.

Note: There is a retaining ring in the groove in the synchromesh disc.

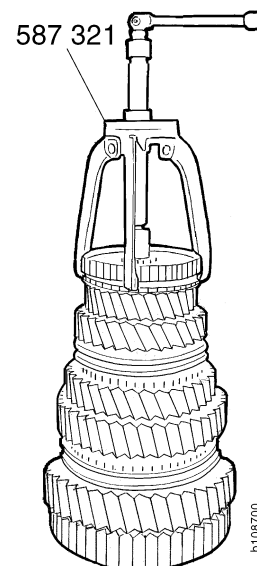

- 5 Remove the 5th gear wheel and bearing.



- 6 Remove the retaining ring for the 4th gear wheel. Pull off the bushing and gear wheel using puller 587 321.
- 7 Remove the bearing.

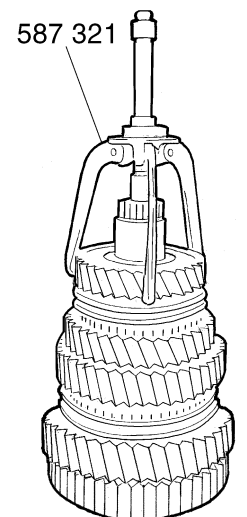

- 8 Remove the loose parts of the synchromesh unit and the 3rd gear wheel.

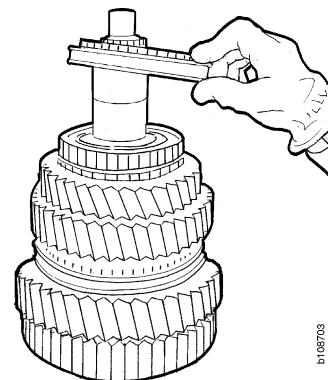

- 9 Rotate the mainshaft and put it back in hollow drift 99 136 and support ring 99 139.

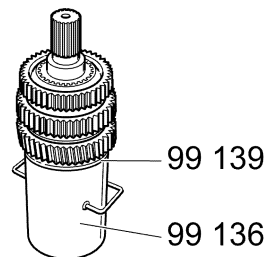

123742

- 10 Pull off the rear bearing inner race, synchromesh disc and reverse gear wheel using puller 587 438. Remove the bearing.

Note: The puller arms must not engage with the synchromesh unit.

IMPORTANT! Place a piece of rubber sheeting or a wooden block under the mainshaft to cushion its fall when it is released.

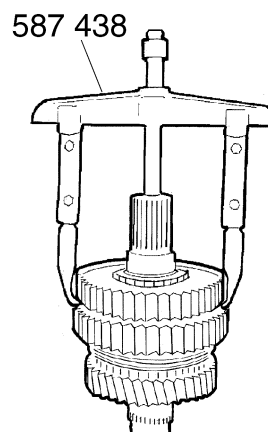

123747

- 11 Pull off the reverse gear wheel inner bearing race and the 1st gear wheel using puller 587 438. Remove the bearing.
- 12 Remove the loose parts of the double synchromesh.

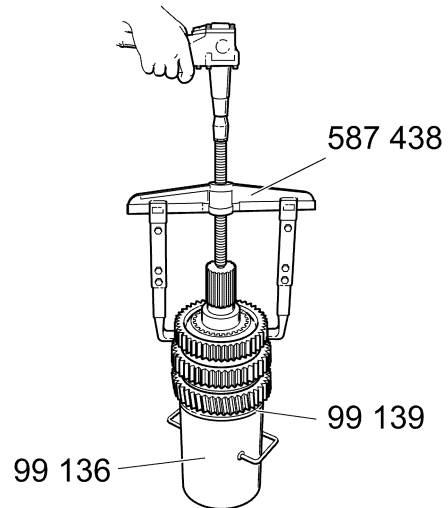

123719

- 13 Remove the double synchromesh retaining ring.

Note: When the double synchromesh retaining ring is removed, the shaft will drop down.

- 14 Remove the double synchromesh and the 2nd gear wheel.
- 15 Remove the bearing.

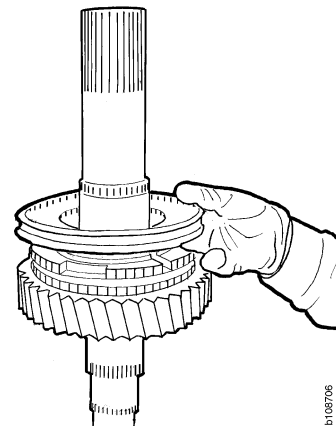

5108706

Assembling the mainshaft







Specifications

Axial clearance

Retaining ring - bearing race

Max 0.10 mm

Special tools

| Number | Description | Illustration | Tool board |
|--------|--------------|---|------------|
| 87 294 | Mandrel |  | AD/AS3, G3 |
| 87 932 | Mandrel |  | D3, G1 |
| 98 322 | Lifting eye |  | G2 |
| 98 413 | Press tool |  | |
| 98 480 | Cap |  | R2 |
| 99 136 | Hollow drift |  | |
| 99 142 | Support ring |  | |

- 1 Clamp the mainshaft in a vice with soft jaws.
- 2 Oil all parts with gearbox oil.
- 3 Fit the 3rd gear bearing and wheel. Fit the synchromesh disc and synchromesh ring.
- 4 Fit the 3rd gear/4th gear driver, heat it to 100°C before fitting.

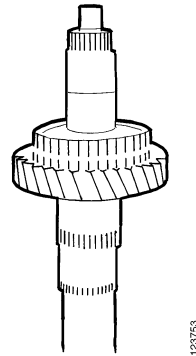

- 5 Fit the shift sleeve and fit the plungers with the rounded portion along the shaft. The shift sleeve grooves must align with the plungers.

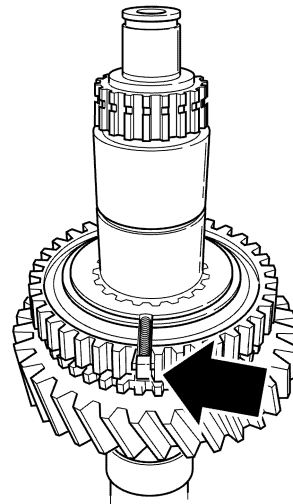

- 6 Fit the 4th gear latch cone and synchromesh disc.
- 7 Fit the 4th gear bearing and wheel.
- 8 Heat the 4th gear inner bearing race to 100°C and tap it on using sleeve 98 480.
- 9 Fit the retaining ring.

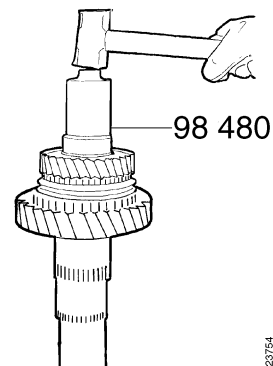

- 10 Measure the axial clearance between the retaining ring and bearing race with a feeler gauge.

Note: Use a retaining ring with a thickness which leaves as little clearance as possible.

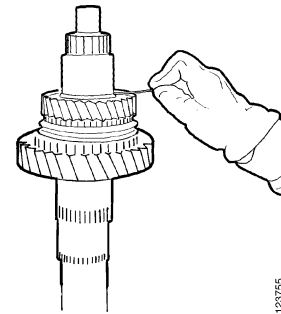

Axial clearance

| | |
|-------------------------------|-------------|
| Retaining ring - bearing race | Max 0.10 mm |
|-------------------------------|-------------|

- 11 Fit the 5th gear bearing and wheel.
- 12 Fit the synchromesh disc (without retaining ring).

- 13 Measure the axial clearance for the 5th gear wheel and select the correct retaining ring. Measure dimension A between the driver contact surface against the shaft and the contact surface against the synchromesh disc, e.g. 7.0 mm.

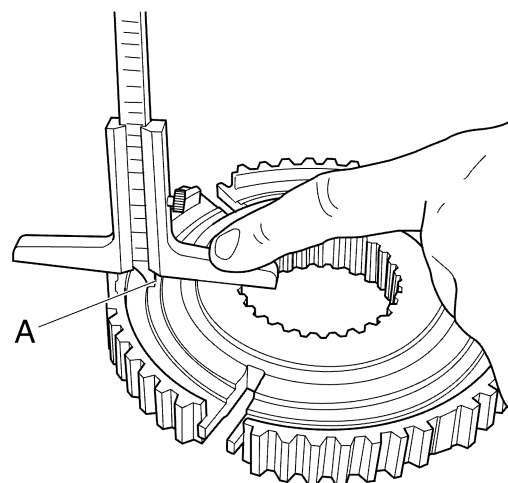

- 14 Measure dimension B between the synchromesh disc and shaft, e.g. 5.9 mm.
- 15 Remove the synchromesh disc from the mainshaft.

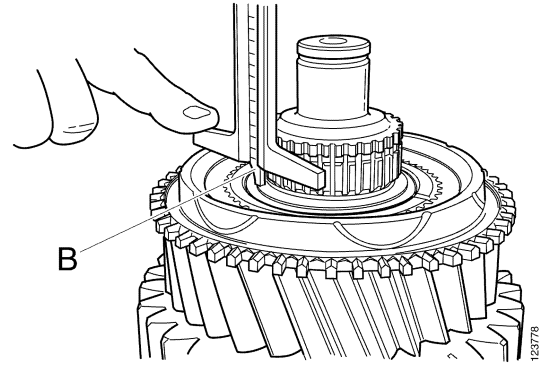

- 16 Measure dimension C from the synchromesh disc surface down to the splines, e.g. 2.4 mm.
- 17 Calculate $A - B + C$, e.g. $7.0 - 5.9 + 2.4 = 3.5$ mm.
- 18 Use a retaining ring for the synchromesh disc which is 0.7 - 1.2 mm less than the calculated value, e.g. $3.5 - 0.7 = 2.8$ mm and $3.5 - 1.2 = 2.3$ mm. The retaining ring should be between 2.3 and 2.8 mm thick in this example. Select a retaining ring which is as thick as possible within the permitted calculated range.

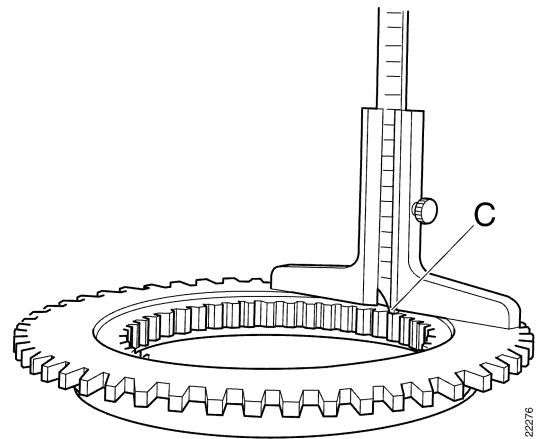

Axial clearance

| | |
|----------------|----------------|
| 5th gear wheel | 0.70 - 1.20 mm |
|----------------|----------------|

- 19 Fit the retaining ring on the synchromesh disc.
- 20 Fit the synchromesh disc and the latch cone.
- 21 Fit the driver. Heat it to 100°C and tap it on using drift 87 932.

Note: The flat side of the driver must face towards the input shaft.

- 22 Fit the retaining ring.
- 23 Measure the axial clearance between the retaining ring and driver with a feeler gauge. Maximum permissible clearance is 0.10 mm. Use a retaining ring with a thickness which leaves the minimum possible clearance.

Axial clearance

| | |
|-------------------------|---------|
| Retaining ring - driver | 0.10 mm |
|-------------------------|---------|

- 24 Heat the bearing to 100°C and tap it on using drift 87 294.

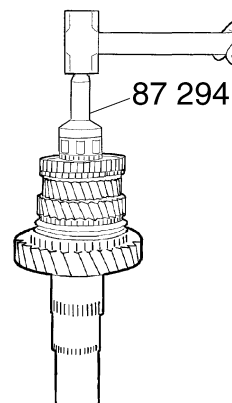

123756

- 25 Fit the retaining ring.
- 26 Rotate the mainshaft and place it on the floor in hollow drift 99 136 and support ring 99 142.
- 27 Fit the bearing on the 2nd gear wheel.
- 28 Fit the synchromesh disc, the inner cone, the intermediate cone and the latch cone. Note the sequence.

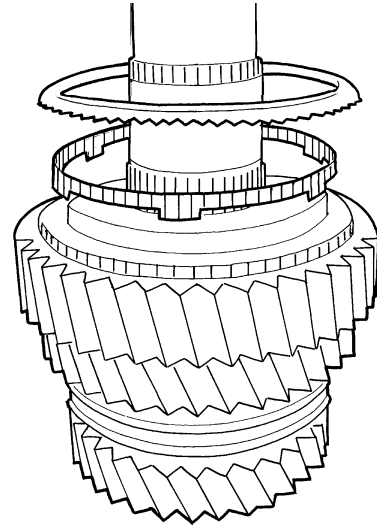

- 29 Heat the driver to 100°C and fit it.

Note: The flat side of the driver must face towards the input shaft.

- 30 Turn the driver to align the latch plates and the plungers with the synchromesh units.
- 31 Fit the retaining ring.

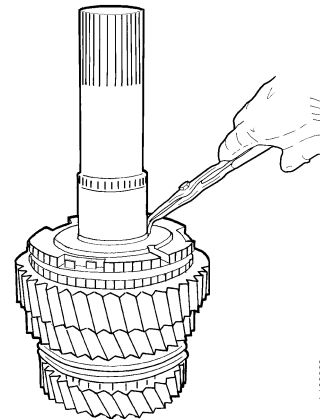

- 32 Fit the latch plates.

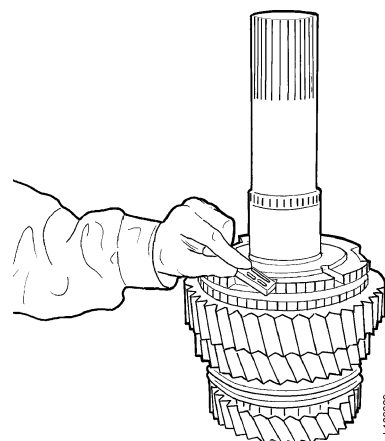

- 33 Measure the axial clearance between the retaining ring and driver with a feeler gauge. Maximum permissible clearance is 0.10 mm. Use a retaining ring with a thickness which leaves the minimum possible clearance.

Axial clearance

| | |
|-------------------------|---------|
| Retaining ring - driver | 0.10 mm |
|-------------------------|---------|

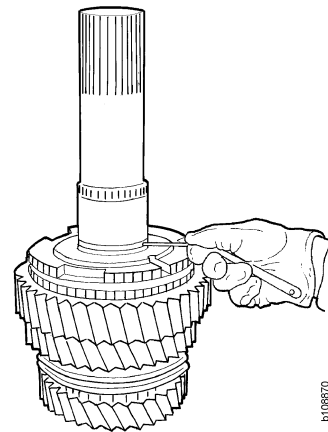

b108670

- 34 Fit the shift sleeve and the plungers. The plunger grooves must align with the plungers.

Note: Make sure that the plungers are fitted with the rounded portion along the shaft.

- 35 Fit the latch cone, the intermediate cone, the inner cone and the synchromesh disc.

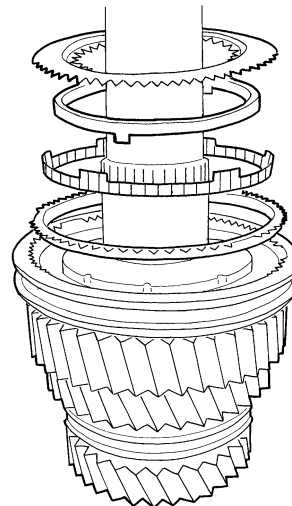

b108674

- 36 Fit the 1st gear bearing and wheel.
- 37 Heat the reverse gear wheel inner bearing race to 100°C and fit the race. If necessary, use press tool 98 413 to tap in the bearing race.

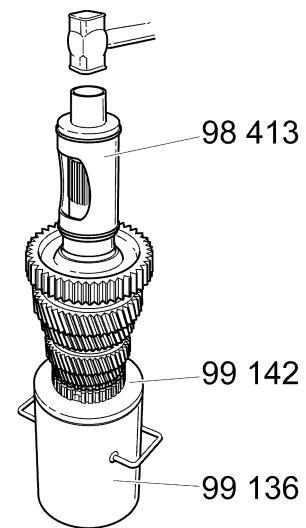

123718

- 38 Fit the bearing and the reverse gear wheel on the mainshaft.
- 39 Heat the reverse gear synchromesh disc to 100° C and fit it.

Note: Flat side against output shaft.



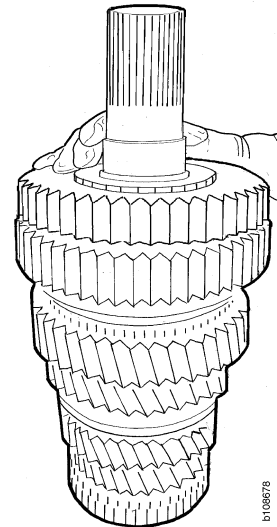



- 40 Heat the rear bearing inner race to 100 °C and fit the race.
- 41 Lift the mainshaft off the hollow drift with 98 322 and the end yoke washer.





b1008678

Dismantling the countershaft

Special tools

| Number | Description | Illustration | Tool board |
|--------|--------------------|--|-------------|
| 87 223 | Mandrel |  | D3, AM2, B1 |
| 87 348 | Mandrel |  | AM1 |
| 87 505 | Mandrel |  | AM1 |
| 98 257 | Support drift |  | AM2, G2 |
| 99 136 | Hollow drift |  | P |
| 99 141 | Support ring |  | P |
| 99 143 | Split support ring |  | P |

Other tools

| Number | Description | Illustration | Tool board |
|---------|-------------|--|------------|
| 587 318 | Disc puller |  | |
| 587 319 | Puller |  | |

- 1 If only the bearing is to be renewed, a destructive removal can be carried out.
- 2 Remove the bearing retaining ring.
- 3 Remove the 6th gear wheel and the rear bearing by pressing, using drifts 87 223, split support ring 99 143 and hollow drift 99 136.

Note: Make sure that the countershaft is not damaged when it drops.

IMPORTANT! Centre the gear wheel on the ring so that the load is uniform.

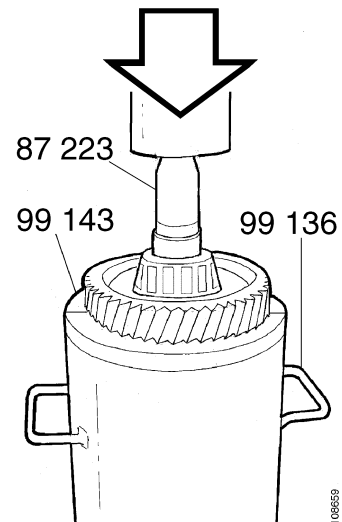

- 4 Remove the 5th gear wheel by pressing, using drifts 87 223, split support ring 99 143 and hollow drift 99 136.

IMPORTANT! Centre the gear wheel on the ring so that the load is uniform.

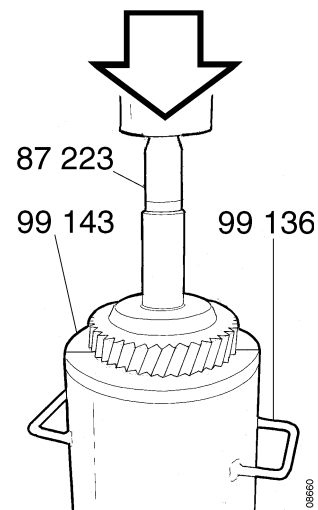

- 5 Remove the 3rd gear/4th gear wheel by pressing, using drifts 87 223, split support ring 99 141 and hollow drift 99 136.

IMPORTANT! Centre the gear wheel on the ring so that the load is uniform.

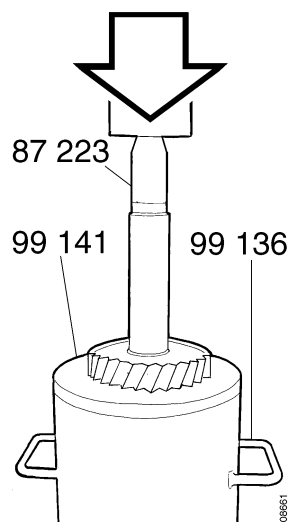

- 6 Remove the bearing from the rear end of the countershaft using drift 98 257, disc puller 587 318 and puller 587 319.

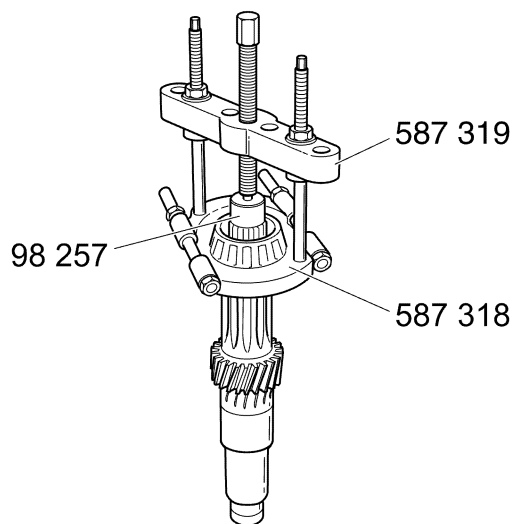

Assembling the countershaft

- 1 Fit the front bearing by pressing, using drift 87 505.
- 2 Fit the front bearing retaining ring.

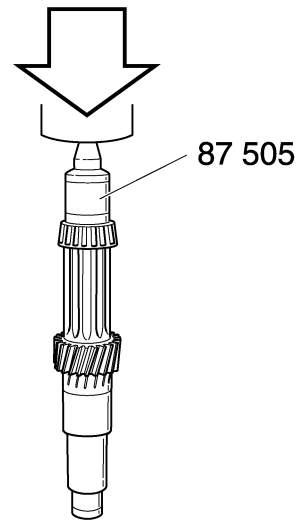

123751

- 3 Fit the 3rd gear/4th gear wheel on the countershaft by pressing, using drifts 98 257, support ring 99 141 and hollow drift 99 136.

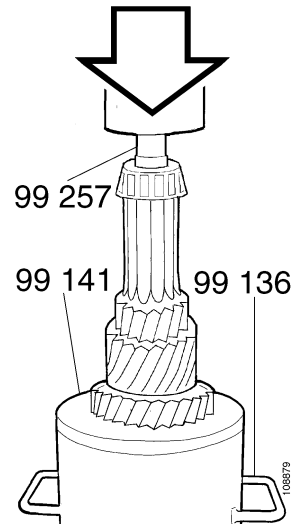

108879

- 4 Fit the 5th gear wheel on the countershaft by pressing, using drifts 98 257, support ring 99 141 and hollow drift 99 136.

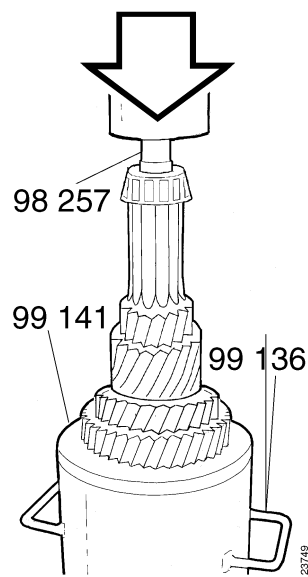

123749

- 5 Fit the 6th gear wheel on the countershaft by pressing, using drifts 98 257, support ring 99 141 and hollow drift 99 136.

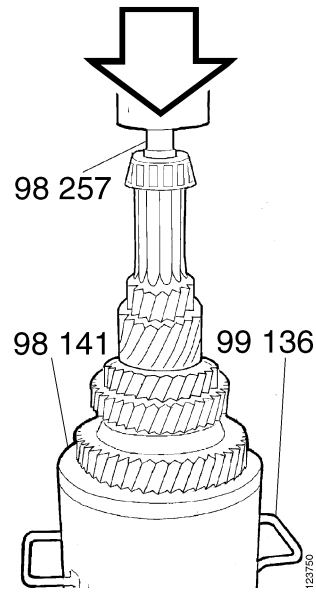

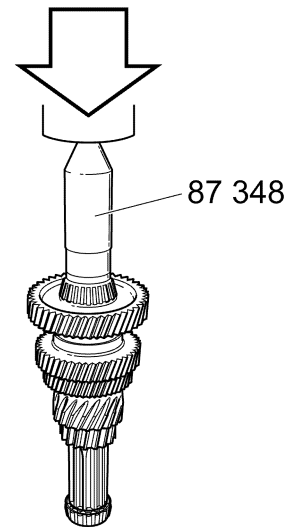

- 6 Fit the rear bearing by pressing, using drift 87 348.



Renewing input shaft seal

Special tools

| Number | Description | Illustration | Tool board |
|--------|-------------|--|------------|
| 87 504 | Mandrel |  | |
| 99 190 | Mandrel |  | G4 |

- 1 Remove the front cover.
- 2 Tap out seal from front cover using drifts 87 504 (with inner socket in 87 504 removed).
- 3 Fit a new seal in the front cover using drifts 87 504 and 99 190.
- 4 Fit front cover on input shaft.
- 5 Tighten bolts on front cover.

Tightening torque

| | |
|--------------------|-------|
| Bolts, front cover | 49 Nm |
|--------------------|-------|

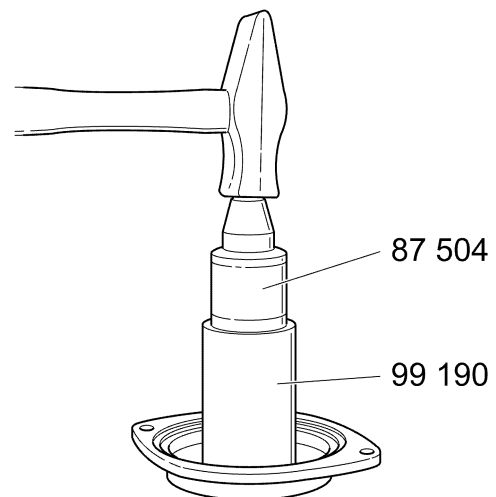

123740

