

SCANIA

05:05-04

Issue 2.3 en

Gearshift housing

Work description

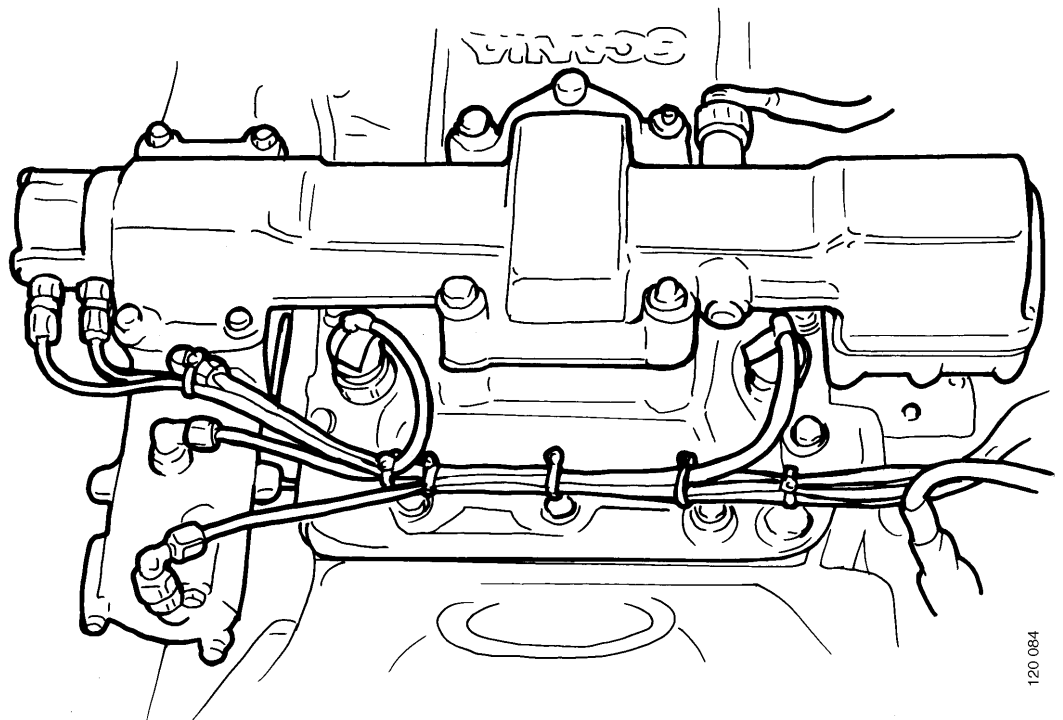

120 084

Contents

General	Air leakage in gear changing control.....	4
Exploded view drawing	Left-hand drive T truck.....	6
	Right-hand drive T truck	8
	Other vehicles	10
	Dismantling	12
	Assembly	15
Opticruise and CS	Dismantling	17
	Assembly	22
Longitudinal stroke cylinder	Dismantling	26
	Assembly	29
Specifications	30

General

IMPORTANT! When reconditioning, all gaskets and seals must be renewed.

Air leakage in gear changing control

Applies to vehicles with Opticruise or Comfort Shift with chassis number lower than:

Truck

Scania Södertälje	1 258 702
Scania Zwolle	4 429 354
Scania Angers	9 050 817

Bus

Scania Katrineholm	1 837 480
--------------------	-----------

A pressure can build up in the damper space resulting in a forward force. The gears engaged with a backward movement might then disengage. This can be prevented by emptying the damper space of any compressed air.

- 1 Remove the gearshift housing from the gearbox.
- 2 Renew O-ring 2 at the lateral stroke cylinder.
- 3 Detach the longitudinal stroke cylinder.
- 4 Drill and thread M10x1 as illustrated.
- 5 Fit the air valve 1 with locking compound.

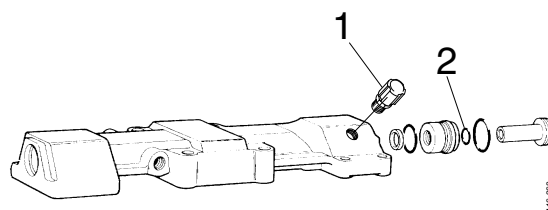

Parts

Pos.	Designation	New part
1	Air valve	234 350
2	O-ring	810 964
	Gasket	1 351 817
	Gasket	1 305 673

Gearshift housing, left-hand drive T truck

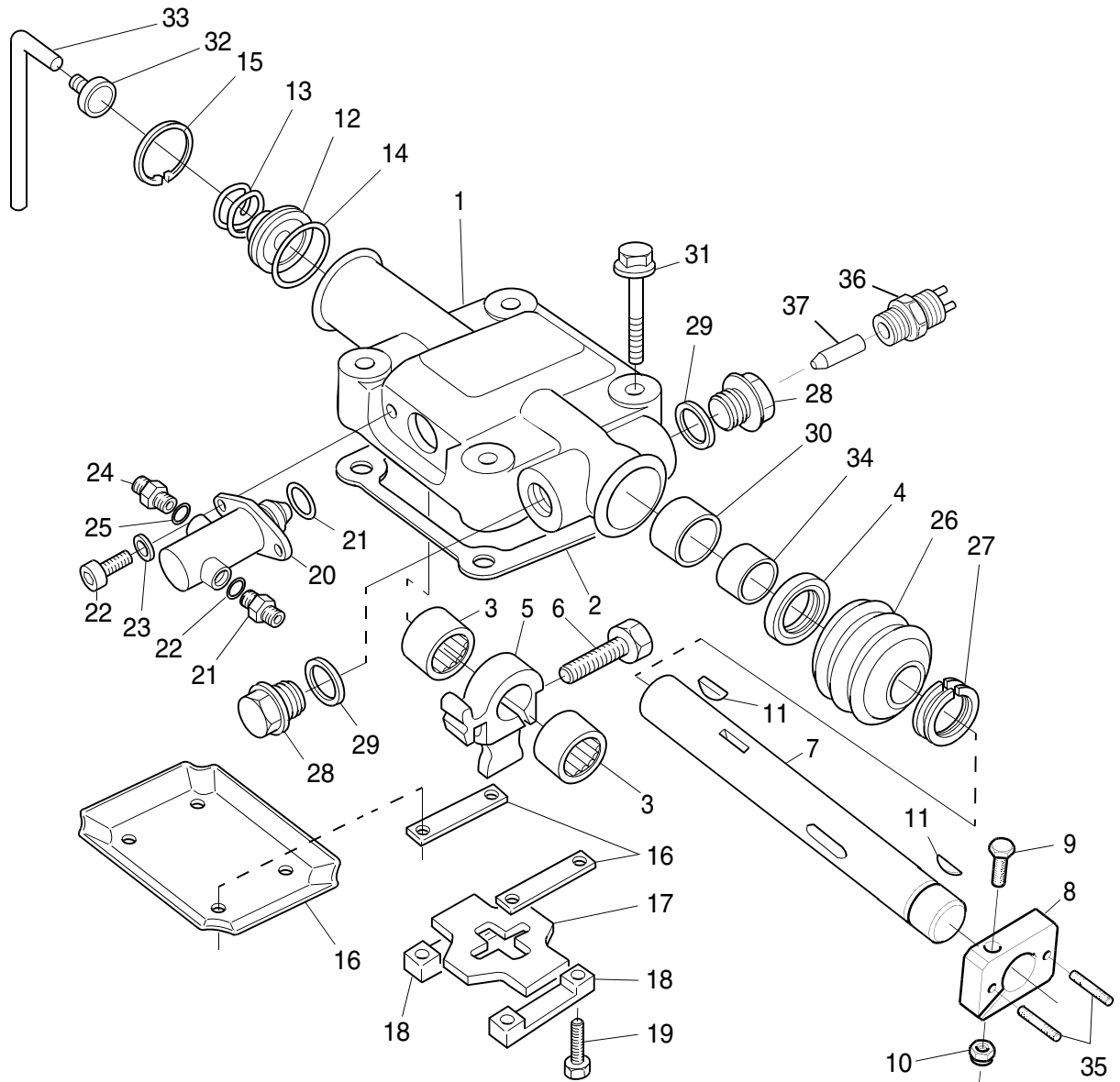

124.701

- 1 *Housing*
- 2 *Gasket*
- 3 *Bearing*
- 4 *Ring*
- 5 *Lever*
- 6 *Screw*
- 7 *Shaft*
- 8 *Driver*
- 9 *Screw*
- 10 *Lock nut*
- 11 *Key*
- 12 *Washer*
- 13 *Spring*
- 14 *O-ring*
- 15 *Retaining ring*
- 16 *Spacer, replaced by protective plate*
- 17 *Coulisse*
- 18 *Cap*
- 19 *Screw*
- 20 *Valve*
- 21 *O-ring*
- 22 *Screw*
- 23 *Washer*
- 24 *Union*
- 25 *O-ring*
- 26 *Boot*
- 27 *Ring*
- 28 *Plug*
- 29 *Gasket*
- 30 *Sleeve*
- 31 *Screw*
- 32 *Plug*
- 33 *Pipe*
- 34 *Bush*
- 35 *Stud*
- 36 *Switch ring*
- 37 *Plunger*

Gearshift housing, right-hand drive T truck

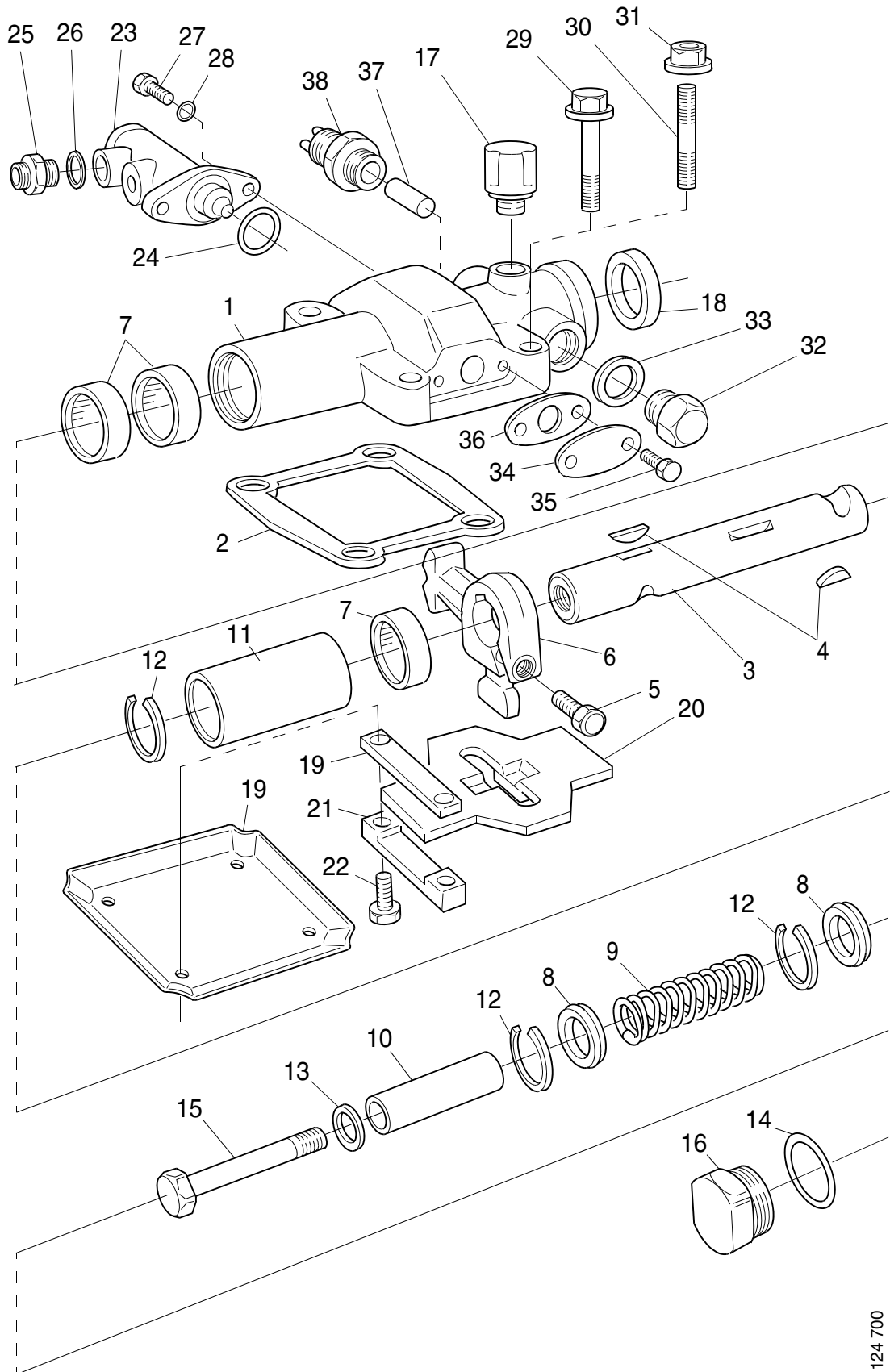

124 700

- 1 *Housing*
- 2 *Gasket*
- 3 *Shaft*
- 4 *Key*
- 5 *Screw*
- 6 *Lever*
- 7 *Bearing*
- 8 *Washer*
- 9 *Spring*
- 10 *Spacer*
- 11 *Pipe*
- 12 *Wire ring*
- 13 *Washer*
- 14 *O-ring*
- 15 *Screw*
- 16 *Plug*
- 17 *Air valve*
- 18 *Ring*
- 19 *Spacer, replaced by protective plate*
- 20 *Coulisse*
- 21 *Cap*
- 22 *Screw*
- 23 *Valve*
- 24 *O-ring*
- 25 *Union*
- 26 *O-ring*
- 27 *Screw*
- 28 *Washer*
- 29 *Screw*
- 30 *Stud*
- 31 *Flange nut*
- 32 *Plug*
- 33 *Gasket*
- 34 *Cover*
- 35 *Screw*
- 36 *Gasket*
- 37 *Plunger*
- 38 *Switch ring*

Gearshift housing, other vehicles

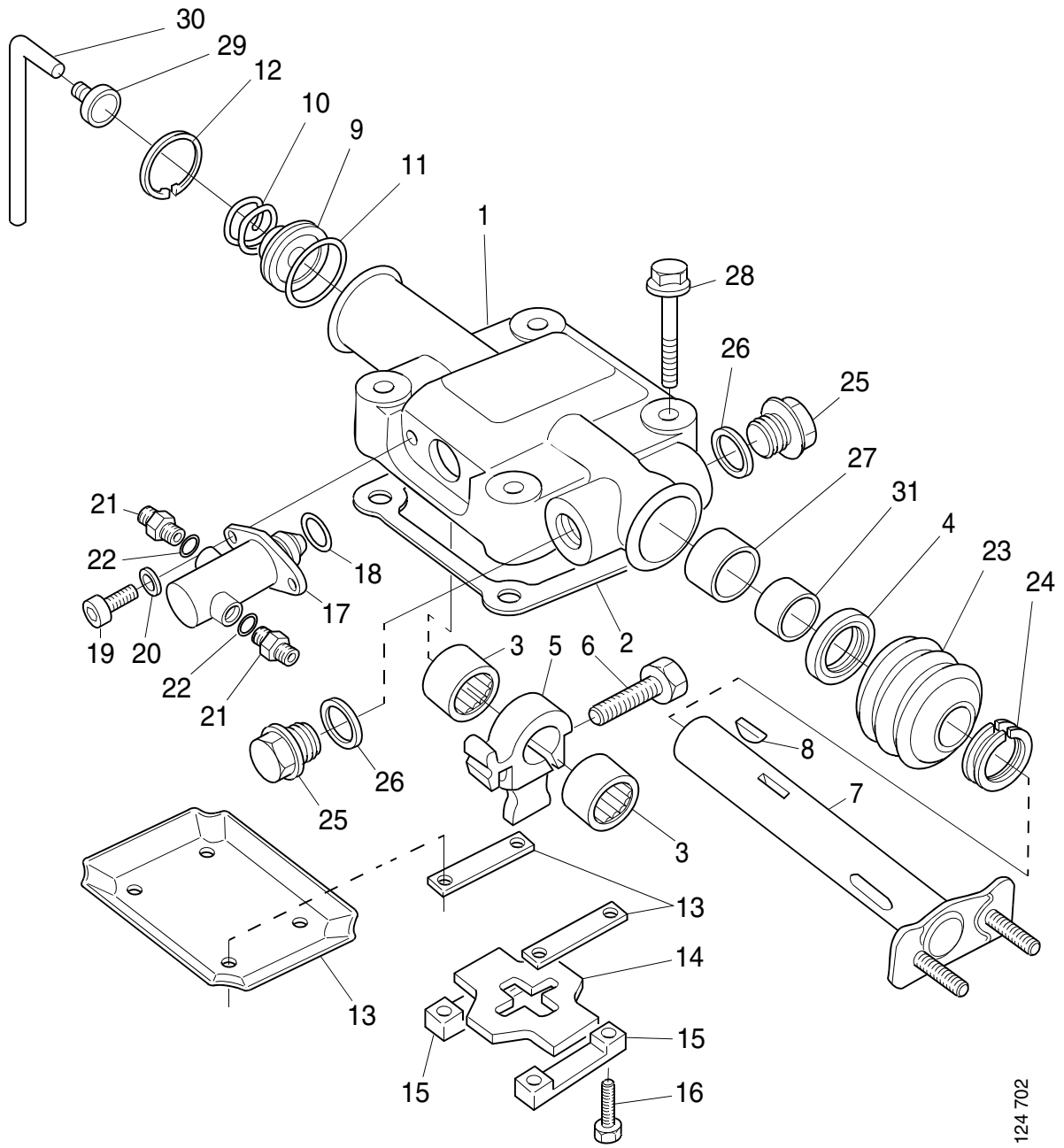



124 702

- 1 *Housing*
- 2 *Gasket*
- 3 *Bearing*
- 4 *Ring*
- 5 *Lever*
- 6 *Screw*
- 7 *Shaft*
- 8 *Key*
- 9 *Washer*
- 10 *Spring*
- 11 *O-ring*
- 12 *Retaining ring*
- 13 *Spacer, replaced by protective plate*
- 14 *Coulisse*
- 15 *Cap*
- 16 *Screw*
- 17 *Valve*
- 18 *O-ring*
- 19 *Screw*
- 20 *Washer*
- 21 *Union*
- 22 *O-ring*
- 23 *Boot*
- 24 *Ring*
- 25 *Plug*
- 26 *Gasket*
- 27 *Sleeve*
- 28 *Screw*
- 29 *Plug*
- 30 *Pipe*
- 31 *Bush*

Dismantling

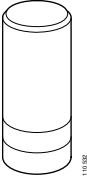
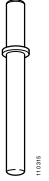
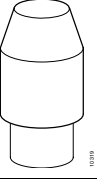
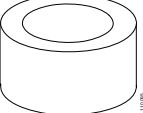
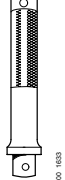
Special tools

Number	Designation	Illustration	Tool board
87 000	Hollow drift	 <p>87 000</p>	AM2
87 362	Drift	 <p>87 362</p>	D3
87 474	Drift	 <p>87 474</p>	D1
98 289	Drift	 <p>98 289</p>	G3
98 450	Shank	 <p>98 450</p>	R2, AD2, AM1
99 382	Drift	 <p>99 382</p>	D1-C6

1

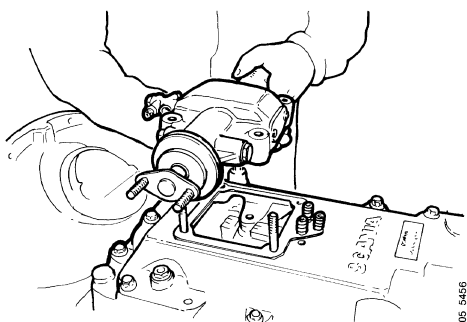

06_5456

2

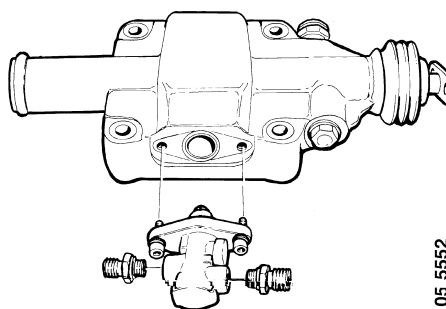

05_5552

3

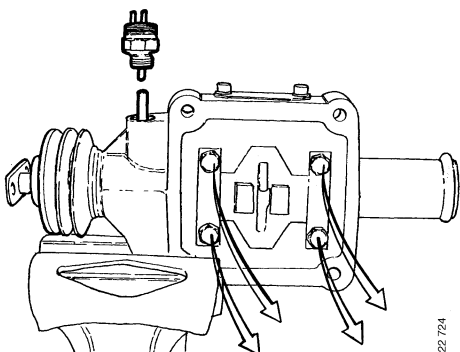

122_724

4

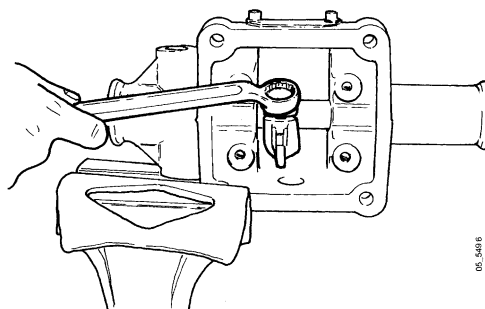

06_5416

5

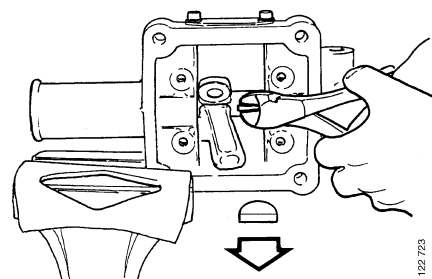

122_723

6

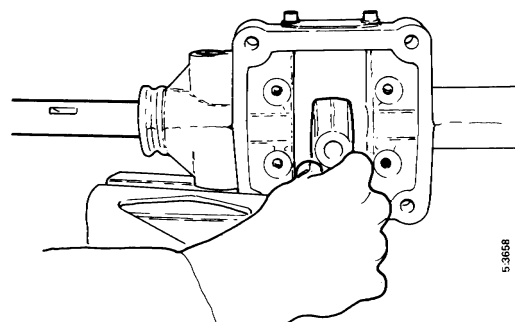

5_3658

7

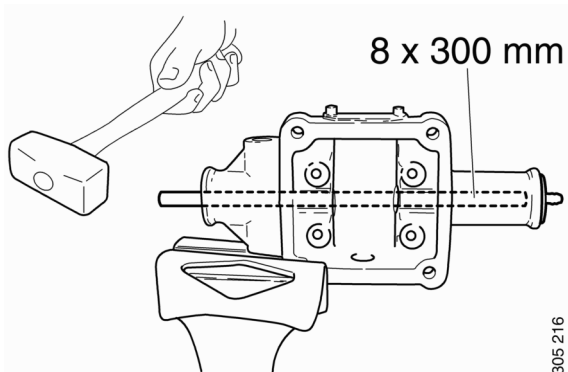

305_216

8

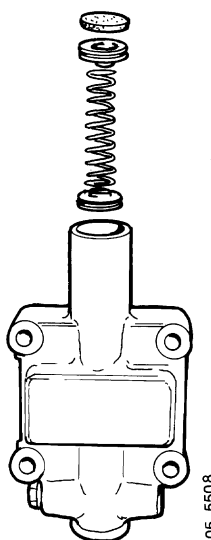

05_5508

9

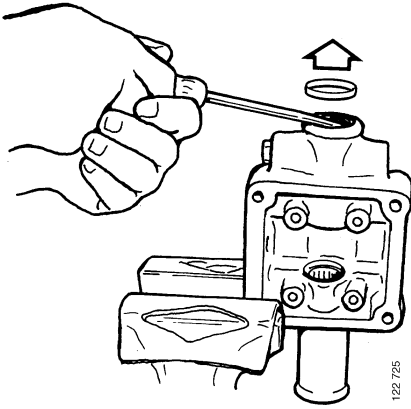

Pressing out bush and bearing.

12

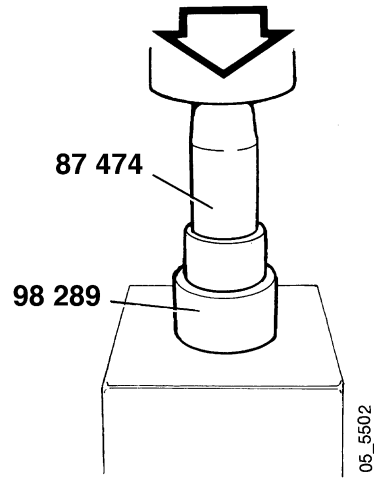

10

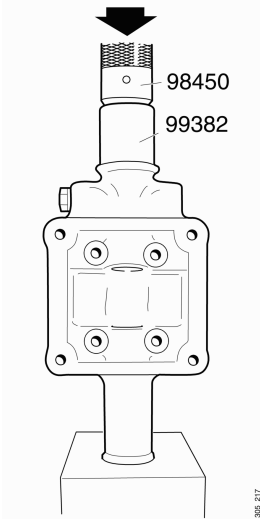

11

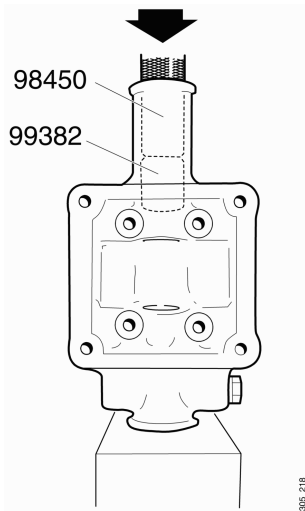

Pressing bush out of sleeve.

Assembly

1

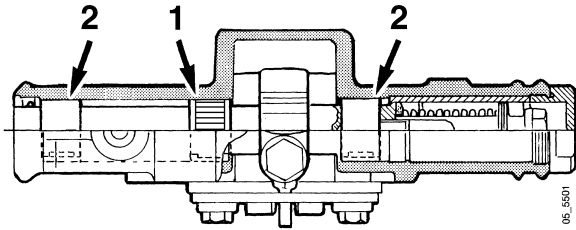

- 1 Location of bearing.
- 2 Location of bearing bush.

2

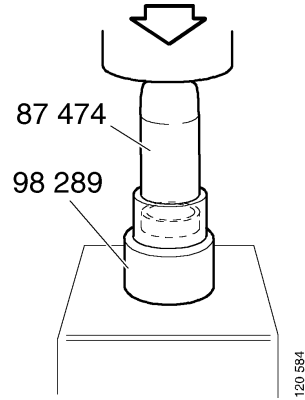

Pressing bush into sleeve.

Note: Bearing bush must be in the centre of the sleeve.

3

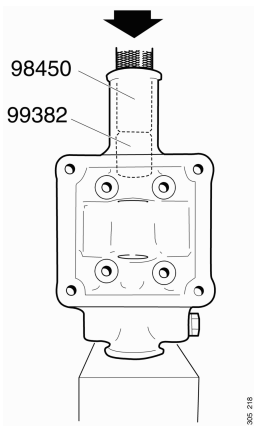

4

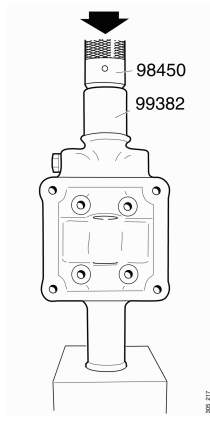

Pressing in bush and bearing.

5

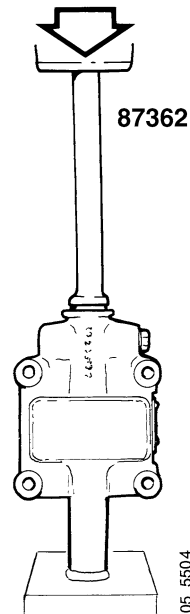

Pressing in a new seal.

6

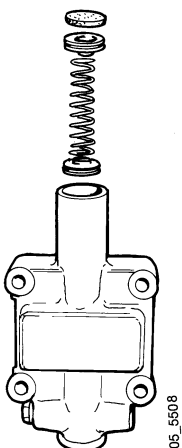

7

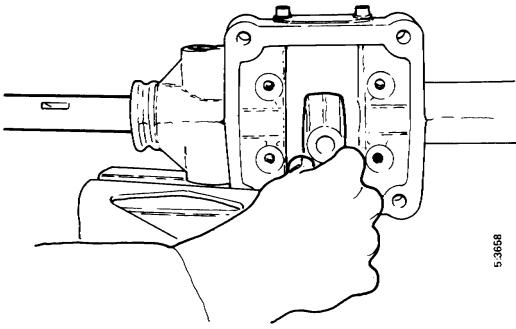

5.3668

8

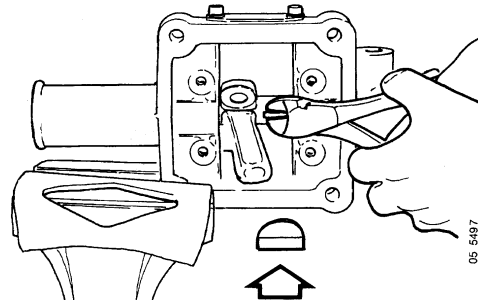

05.5497

9

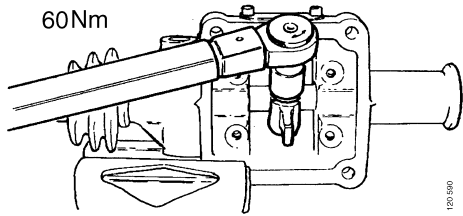

60Nm

120.090

10

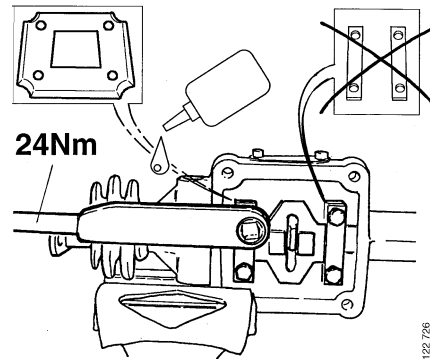

24Nm

122.726

11

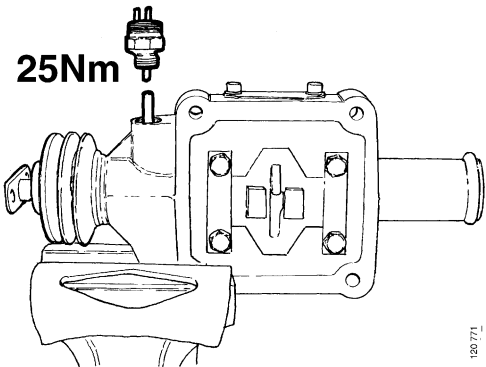

25Nm

120.771

12

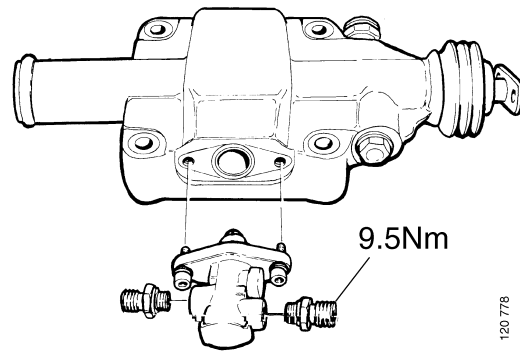

9.5Nm

120.778

Gearshift housing for Opticruise and CS

Dismantling

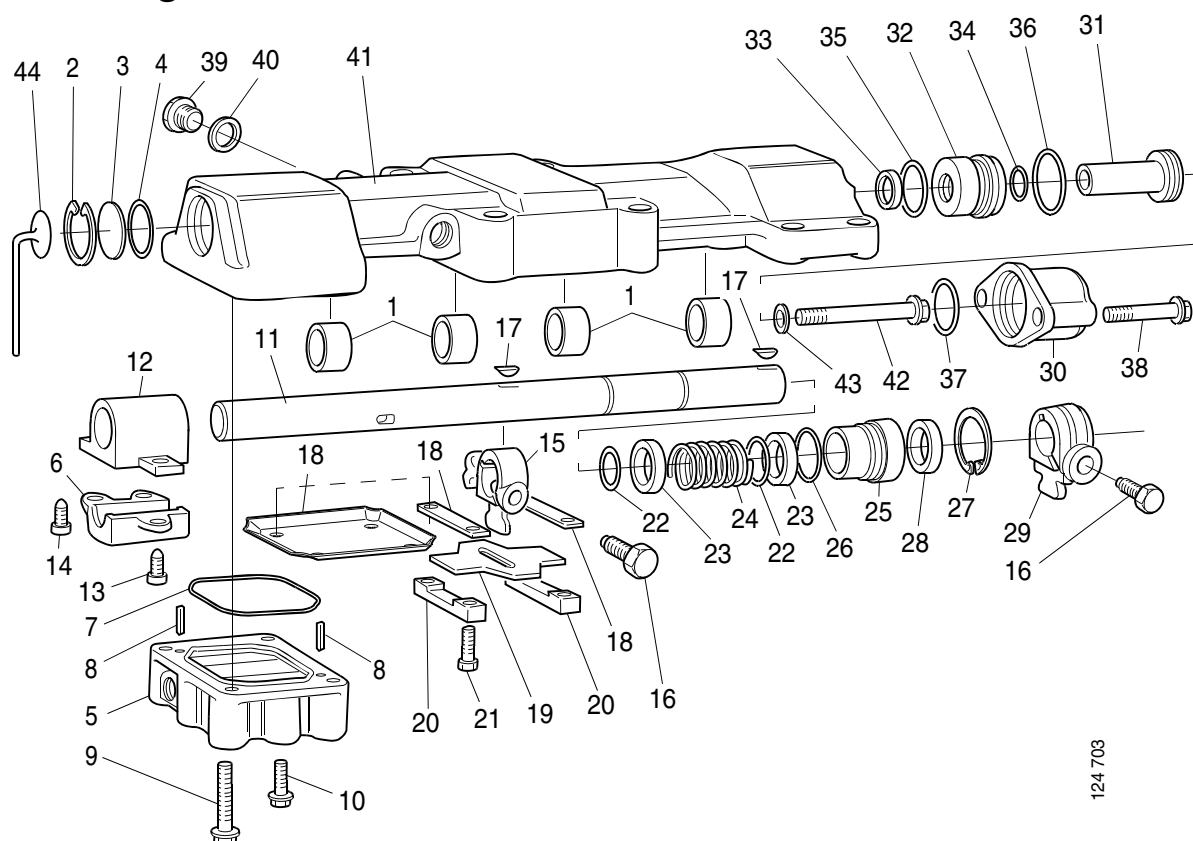

124 703

- | | |
|---|--------------------------|
| 1 Bush | 23 Washer |
| 2 Retaining ring | 24 Spring |
| 3 Filter | 25 Intermediate piece |
| 4 O-ring | 26 O-ring |
| 5 Sensor housing | 27 Retaining ring |
| 6 Magnet housing | 28 V-ring |
| 7 O-ring | 29 Lever |
| 8 Pin | 30 Cylinder |
| 9 Screw | 31 Piston |
| 10 Screw | 32 Intermediate piece |
| 11 Shaft | 33 V-ring |
| 12 Magnetic bracket | 34 O-ring |
| 13 Screw | 35 O-ring |
| 14 Screw | 36 O-ring |
| 15 Lever | 37 O-ring |
| 16 Screw | 38 Screw |
| 17 Key | 39 Plug |
| 18 Spacer, replaced by protective plate | 40 Gasket |
| 19 Coulisse | 41 Housing |
| 20 Cap | 42 Screw |
| 21 Screw | 43 Washer |
| 22 Wire ring | 44 Cover with bleed hose |

1

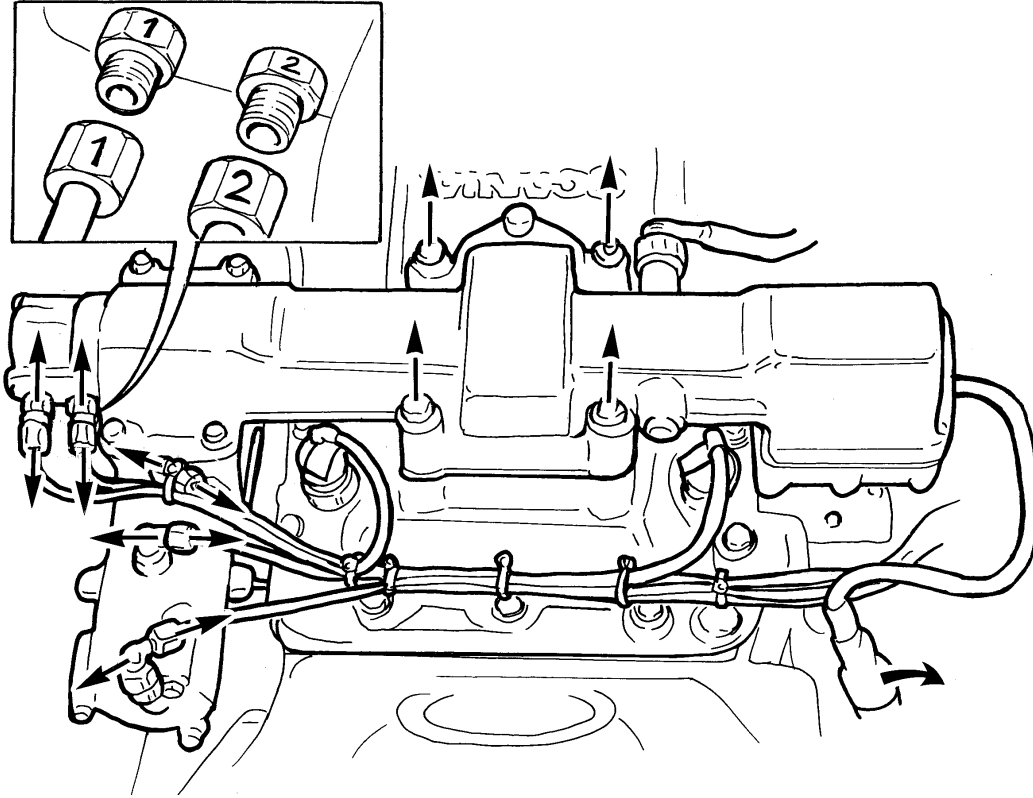

IMPORTANT! Mark all connections.

2

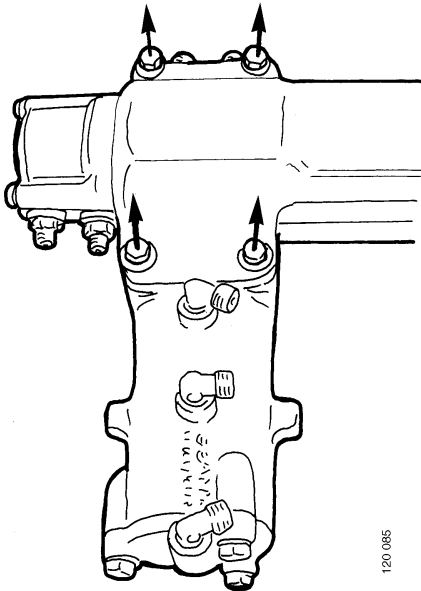

3

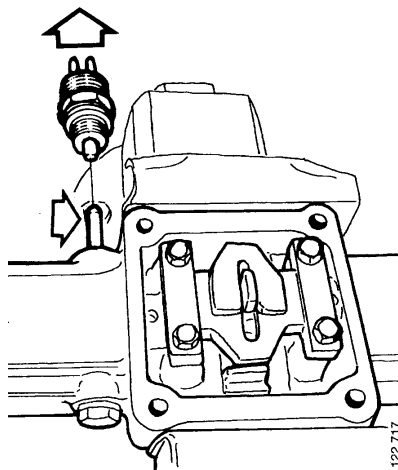

4

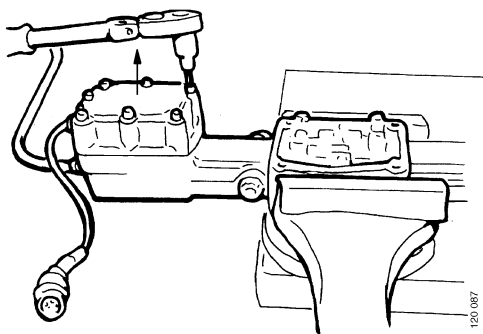

5

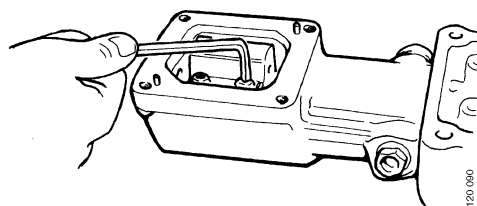

Note: These bolts are secured in position using locking compound. Do not heat, as this may damage the magnet housing.

6

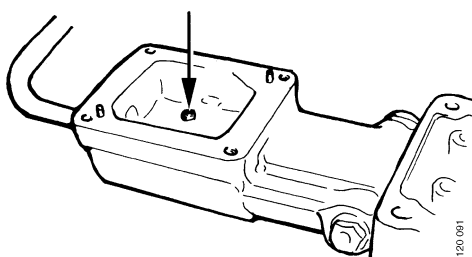

7

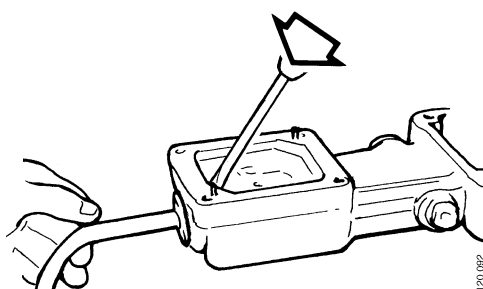

Note: Mark how the magnet housing bracket should sit on the shaft so that it is not turned during assembly.

8

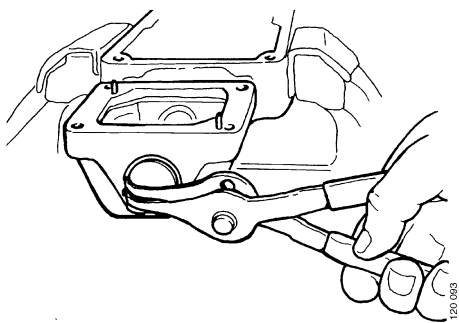

9

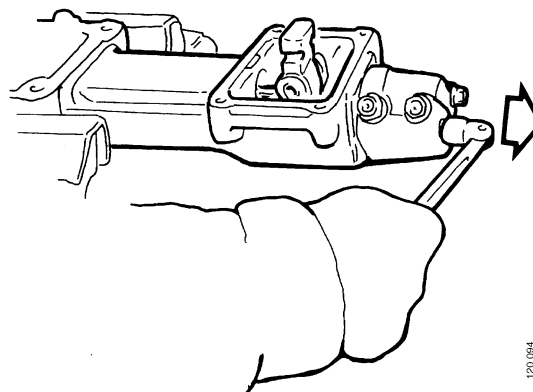

Old design

10

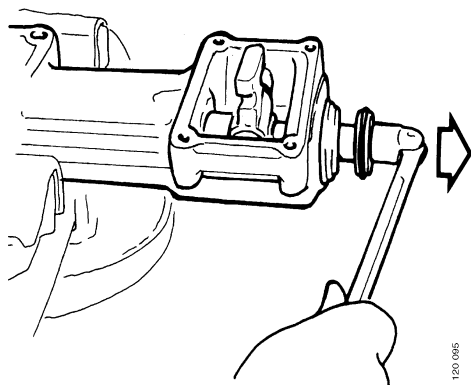

11

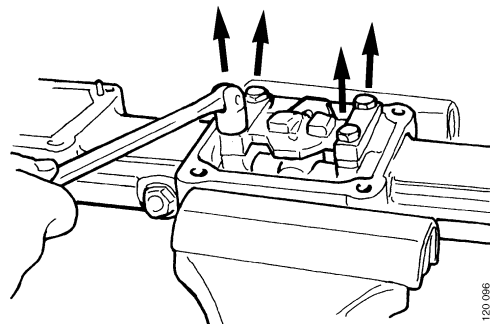

12

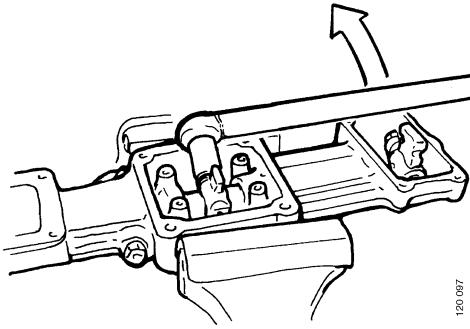

120 097

13

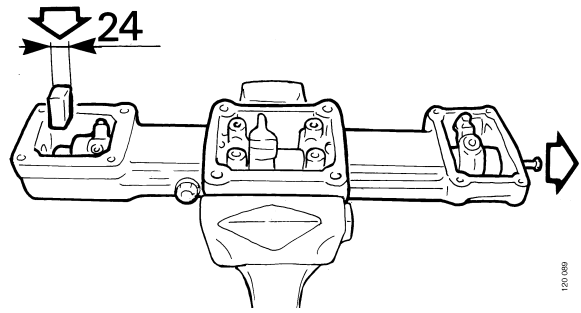

120 099

Screw in a screw at the end of the shaft and pull the shaft forward. Place a spacer approx. 24 mm between the shaft and end plate.

14

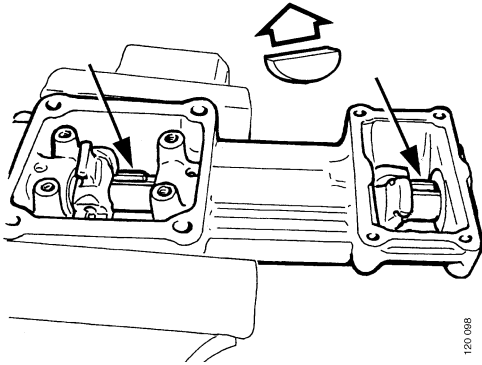

120 098

15

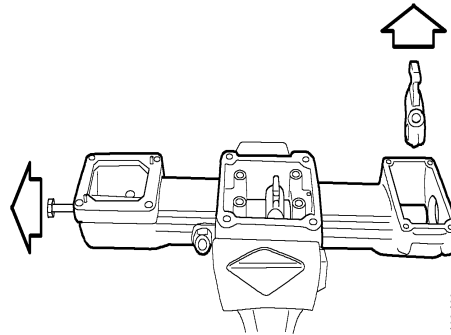

120 162

Screw in a screw at the other end of the shaft and pull the shaft forward.

16

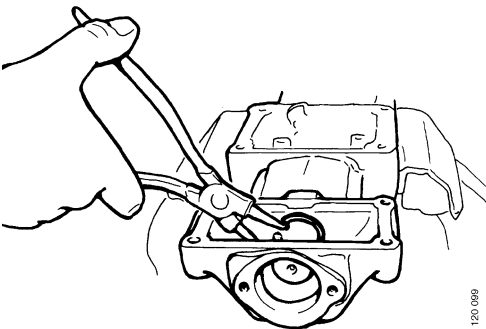

120 099

17

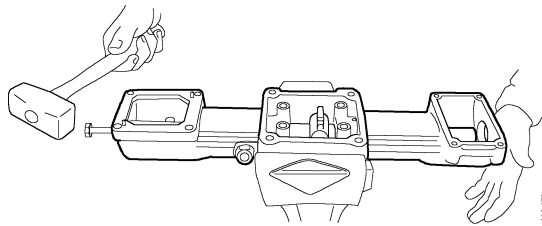

120 173

18

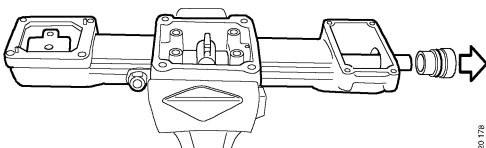

120 178

19

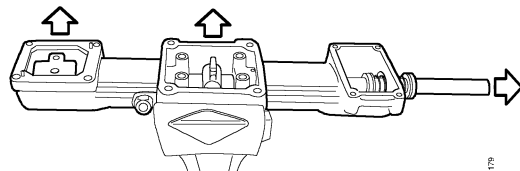

120 179

20

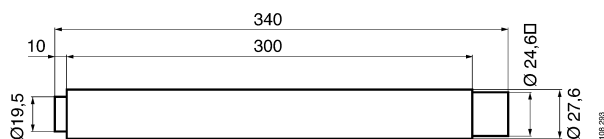

A drift must be made to tap out the bushes; see illustration. The end with the 19.5 mm diameter is used for a bearing sleeve in a longitudinal stroke cylinder.

21

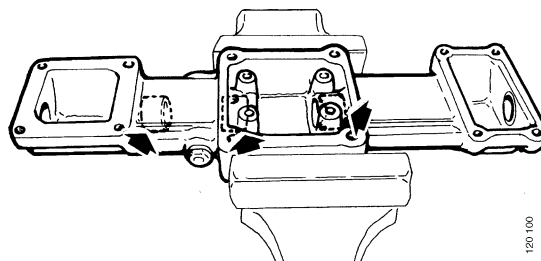

Tap out the bushes, two from the magnet side and one from the lateral stroke side.

22

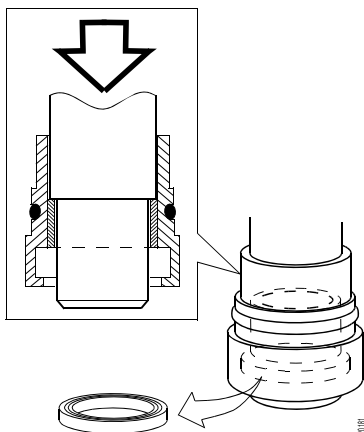

To tap out the bushes from the intermediate piece, the V-ring must be removed.

Assembly

1

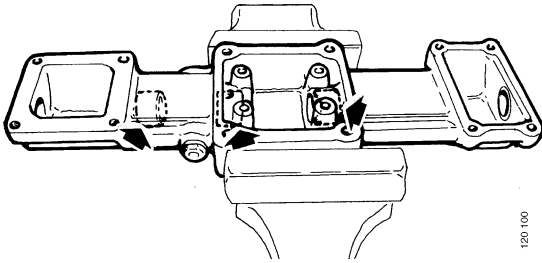

2

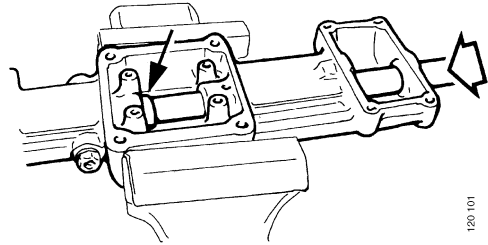

Tap in the bushes in the correct order. It is important that the centre bushes are tapped in first.

First bush

3

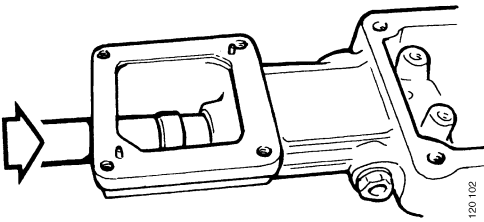

Second bush

4

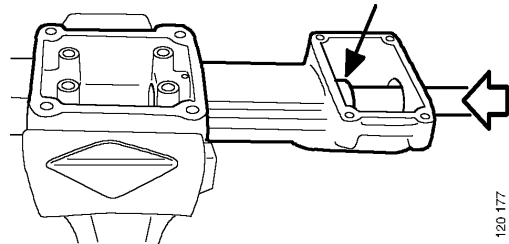

Third bush

5

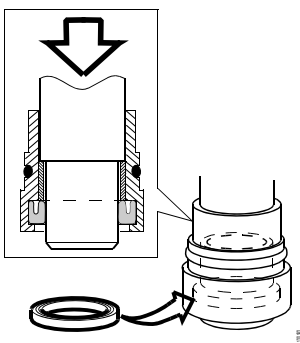

6

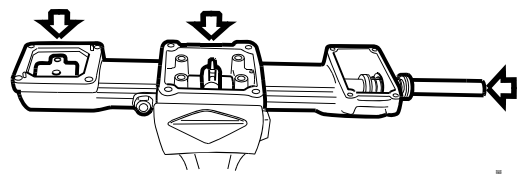

Note: Fit the magnet housing in accordance with the marks made previously.

7

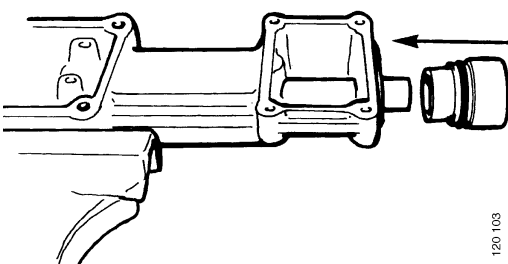

8

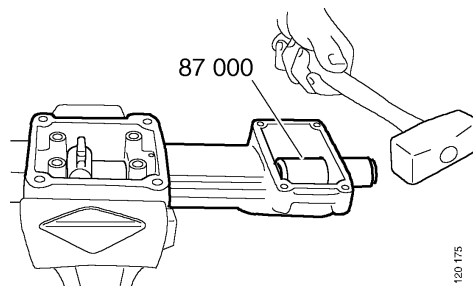

9

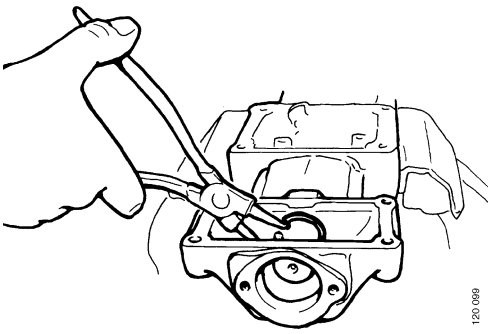

120 089

10

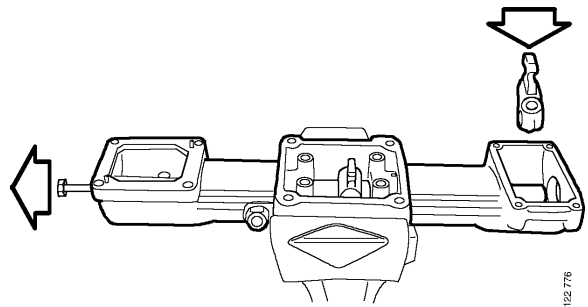

122 776

11

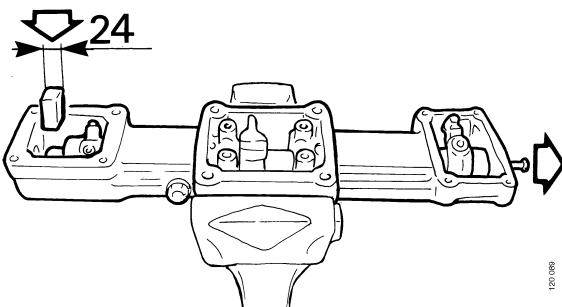

120 089

12

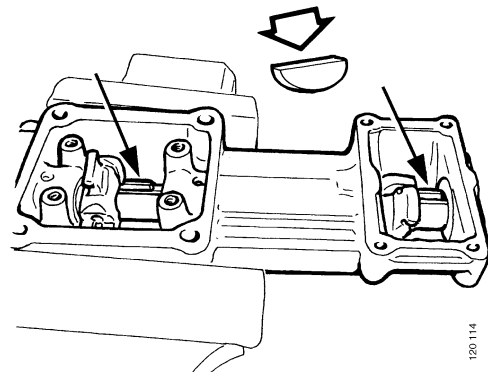

120 114

13

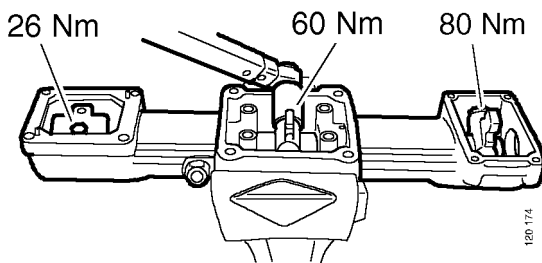

120 174

14

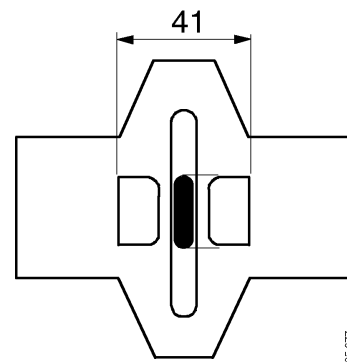

125 677

Place lever centrally before the coulisse stop lugs.

15

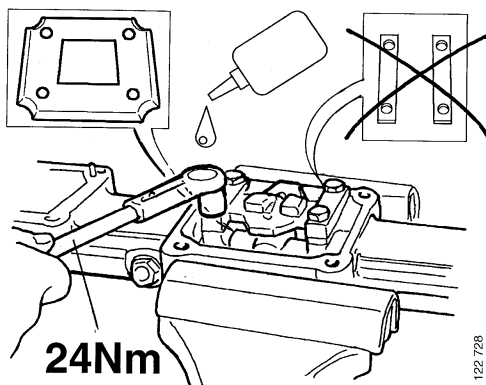

122 728

16

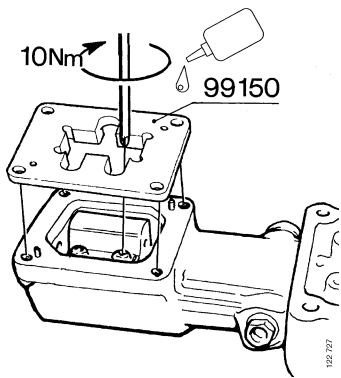

17

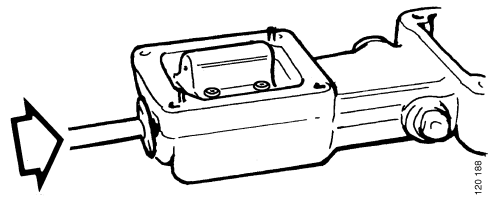

18

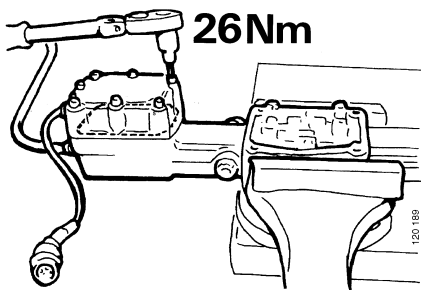

19

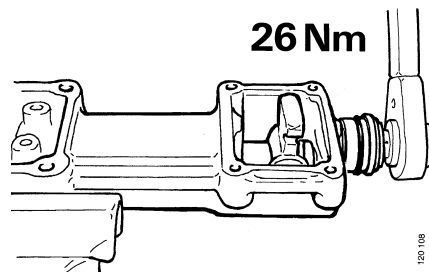

20

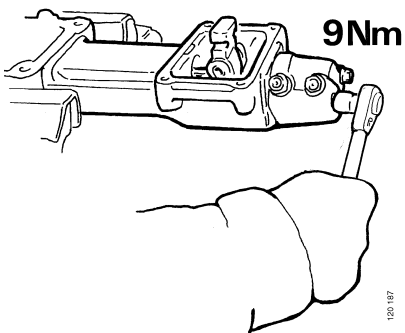

21

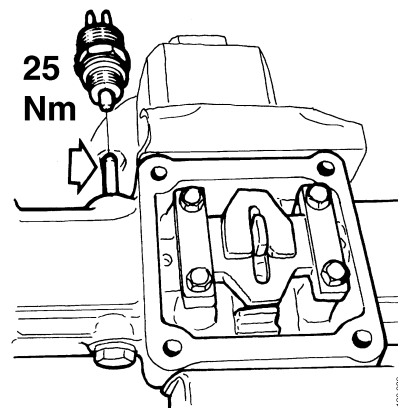

22

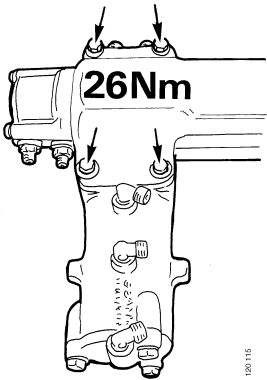

23

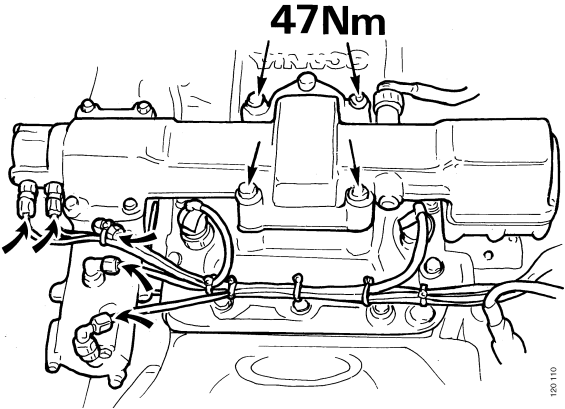

24

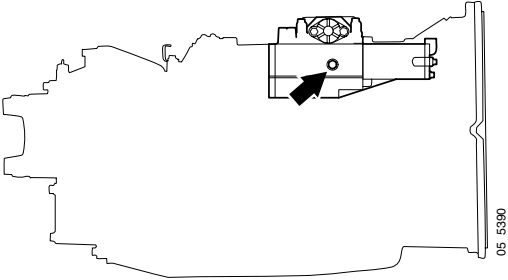

Top up ATF oil to level plug.

Longitudinal stroke cylinder

Dismantling

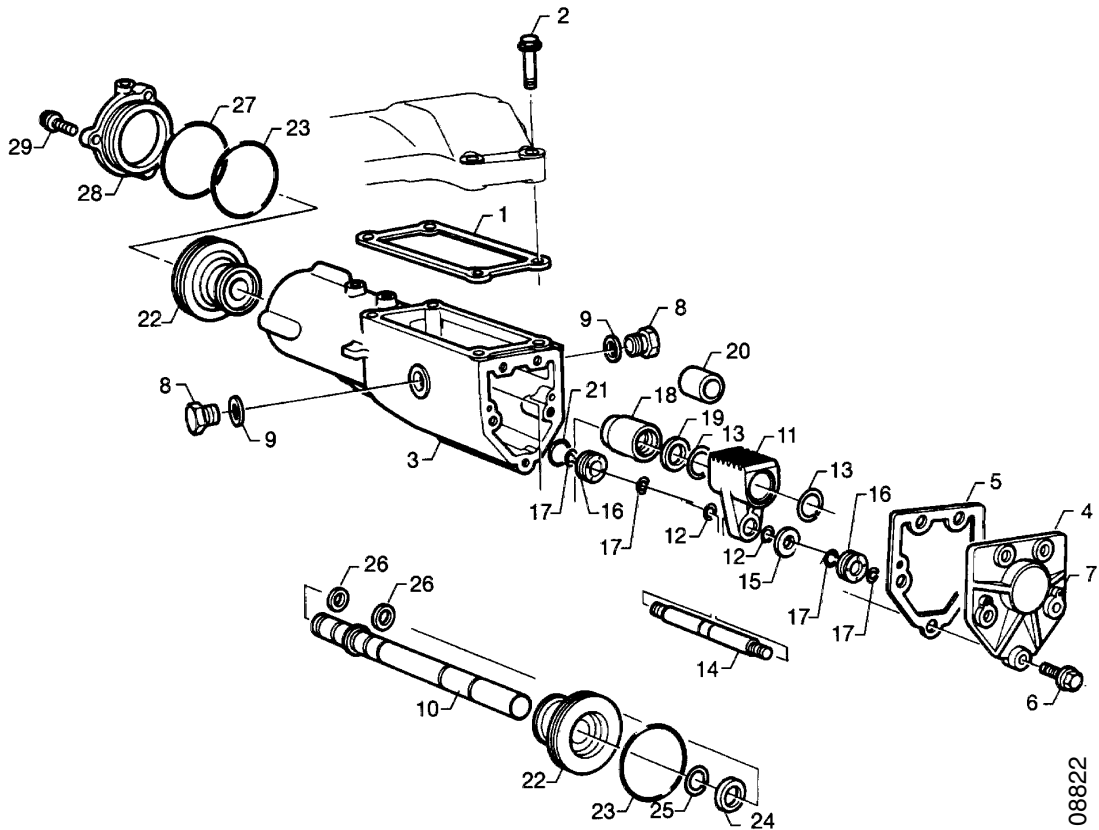

108822

Old design

- | | |
|--------------------|-----------------|
| 1 Gasket | 19 V-ring |
| 2 Screw | 20 Bearing |
| 3 Control cylinder | 21 O-ring |
| 4 End plate | 22 Piston |
| 5 Gasket | 23 O-ring |
| 6 Screw | 24 Washer |
| 7 Pin | 25 Washer |
| 8 Plug | 26 Sealing ring |
| 9 Gasket | 27 O-ring |
| 10 Piston rod | 28 End plate |
| 11 Rack | 29 Screw |
| 12 Wire ring | |
| 13 Wire ring | |
| 14 Piston rod | |
| 15 Washer | |
| 16 Piston | |
| 17 Wire ring | |
| 18 Bearing sleeve | |

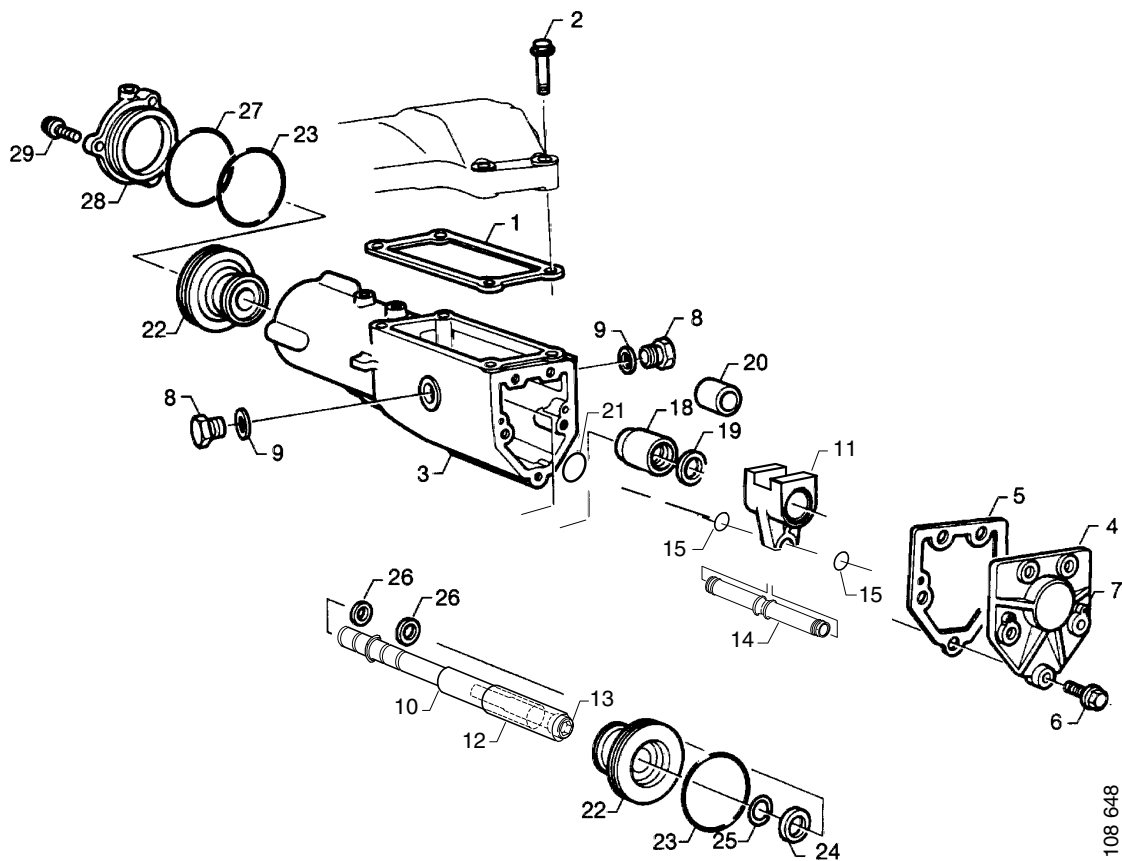

108 648

Newer design

- | | |
|--------------------|-----------------|
| 1 Gasket | 19 O-ring |
| 2 Screw | 20 Piston |
| 3 Control cylinder | 21 O-ring |
| 4 End plate | 22 Washer |
| 5 Gasket | 23 Circlip |
| 6 Screw | 24 Sealing ring |
| 7 Pin | 25 O-ring |
| 8 Plug | 26 End plate |
| 9 Gasket | 27 Screw |
| 10 Piston rod | |
| 11 Rack | |
| 12 Clamp sleeve | |
| 13 Screw | |
| 14 Piston | |
| 15 Piston ring | |
| 16 Bearing sleeve | |
| 17 V-ring | |
| 18 Bearing | |

1

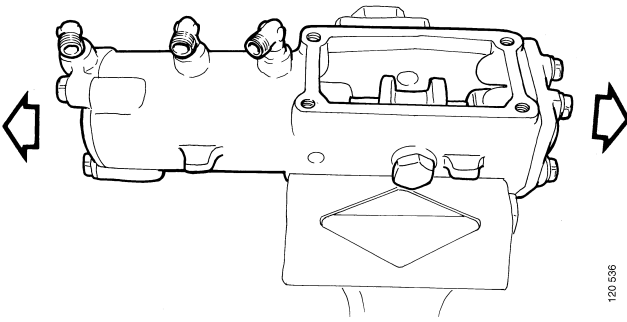

2

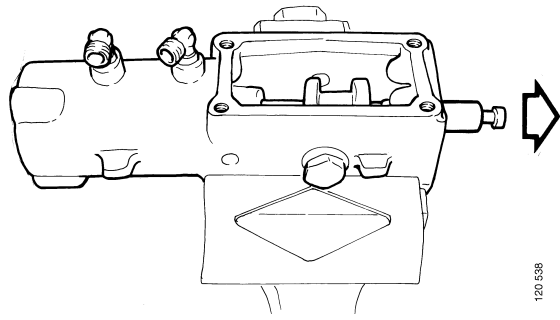

Remove the bolt and clamp sleeve.

3

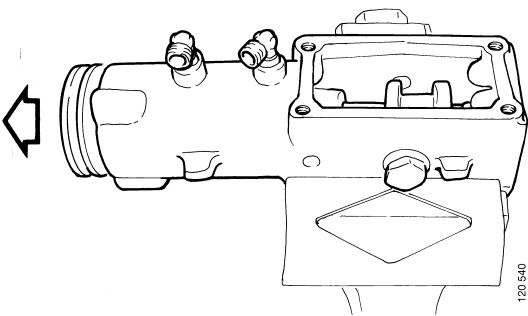

4

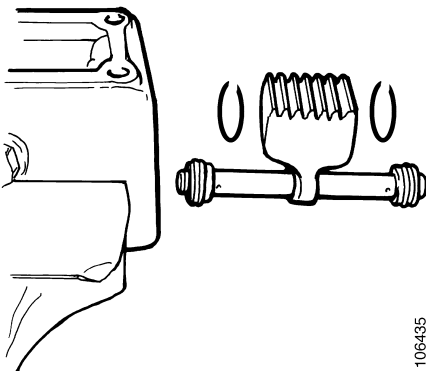

Old design

6

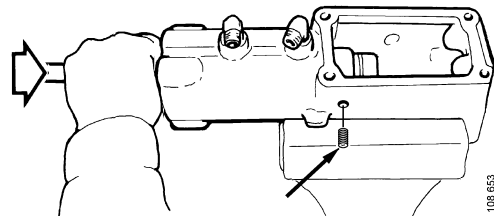

Remove the bearing sleeve set screw. Old design has no lock bolt. Use the end with the 19.5 mm diameter on the previously made drift.

7

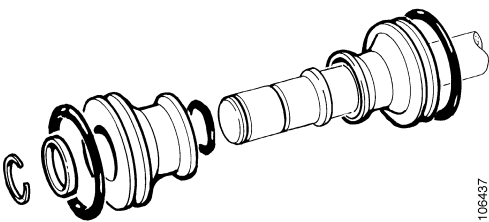

8

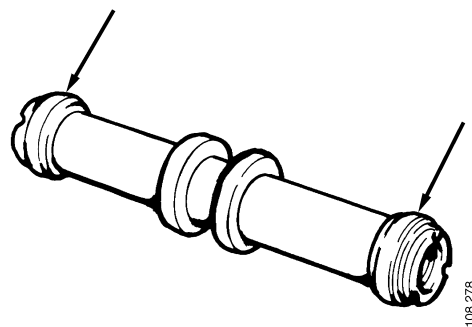

Renew the piston rings carefully with your fingers.

Assembly

1

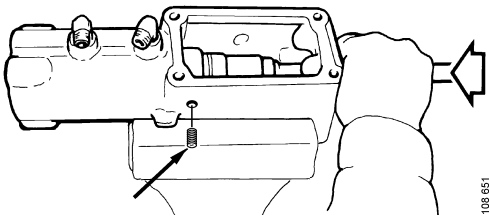

Use locking compound 815 356 for the bearing sleeve on the longitudinal stroke cylinders that does not have a lock bolt.

2

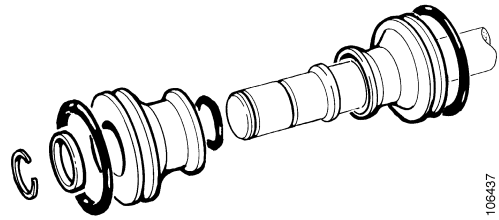

3

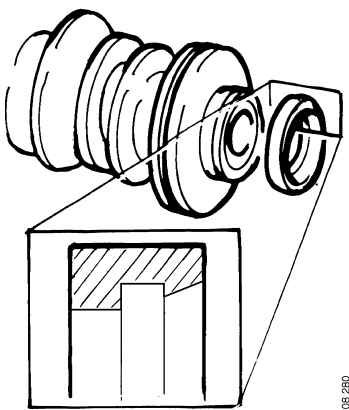

4

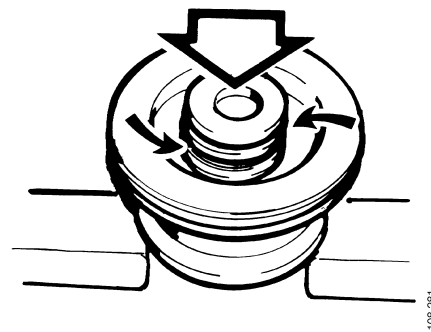

Tap on the shaft so that the lock washer fits onto the retaining ring.

5

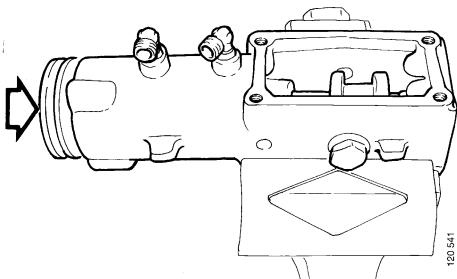

Grease cylinder and the O-ring.

6

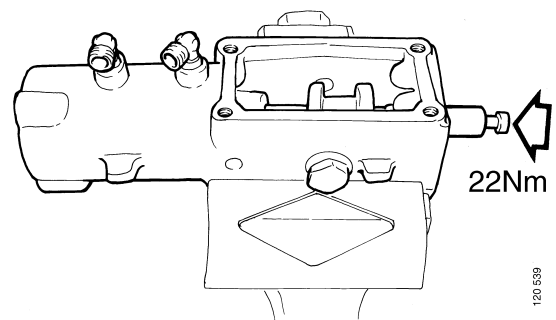

7

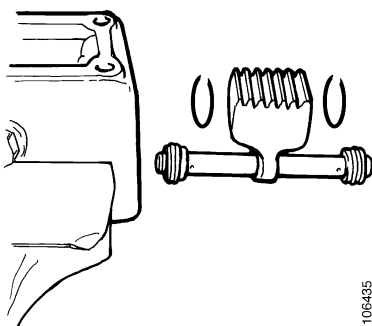

Old design

8

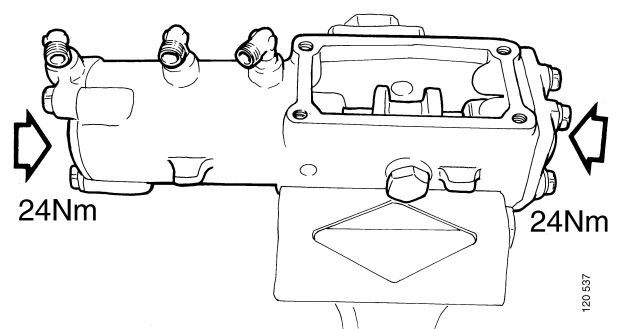

Specifications

Tightening torques

Lever	60 Nm
Lever (outer)	80 Nm
Switch	25 Nm
Union	9.5 Nm
Coulisse	24 Nm
Magnetic bracket	26 Nm
Magnet housing	10 Nm
Sensor housing	26 Nm
Lateral stroke piston	26 Nm
Lateral stroke cylinder	9 Nm
Clamp sleeve	22 Nm
End plate	24 Nm
Longitudinal stroke cylinder	26 Nm
Gearshift housing to gearbox	47 Nm

Special tools

Number	Designation	Tool board
87 000	Hollow drift	AM2
87 362	Drift	D3
87 474	Drift	D1
98 289	Drift	G3
98 450	Shank	R2, AD2, AM1
99 053	Drift	D1

