

SCANIA

19:04-01

Issue 2 en

Electrical engine heater, cab socket

Work description

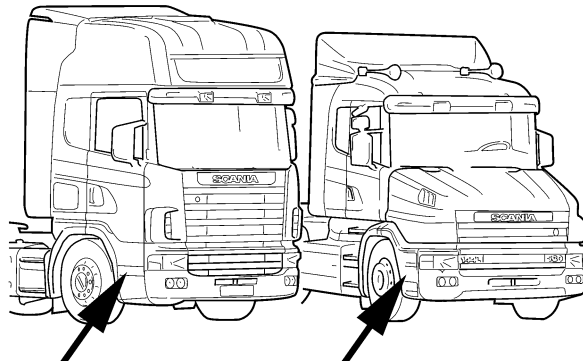
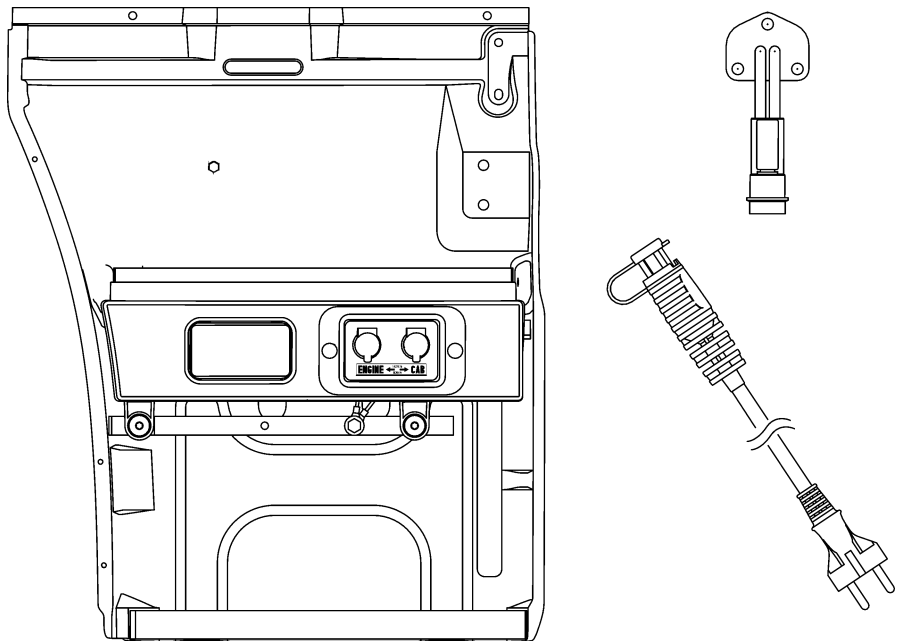

121 908

Contents

General	3
Input cable	R/P cab..... 4
	T cab 5
Cab socket cable	Cab attachment, front 7
	CR/T/P-14 8
	CR/CP-19 9
	CT19, CP28-31 10
Cab socket	11
Engine heater element	9 litre engine 12
	11, 12 litre engines 13
	14 litre engine 14
	16 litre engine 15

General

Since the amount of parts used from the basic mounting kit varies depending on the cab and the engine fitted to the vehicle, some parts, like clamps and bolts, might be left over. Follow the instructions for your specific vehicle and clamp the cables to avoid chafing.

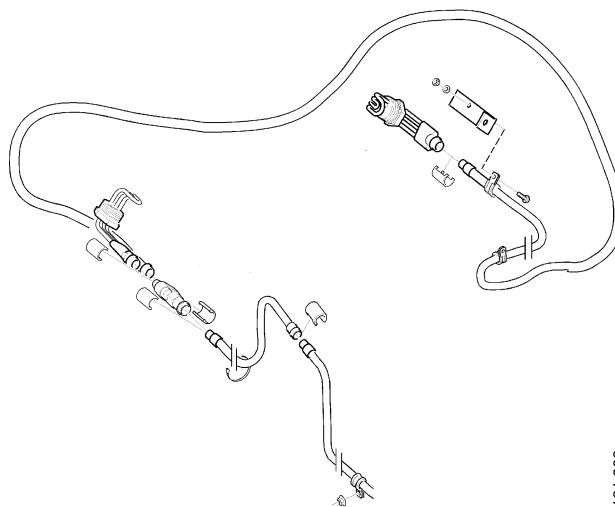

121 909

Some cabs are fitted with studs welded into the lower cab beams. Use them together with a special nut and a rubber lined clamp when clamping the cab socket cable. If no studs are fitted, you should drill and fit the rubber lined clamp using a plate screw.

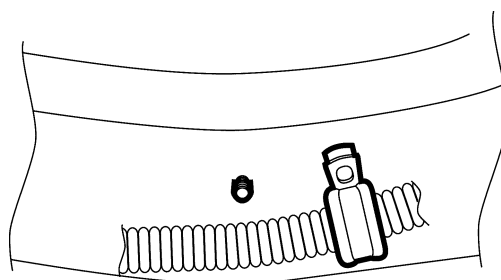

123 449

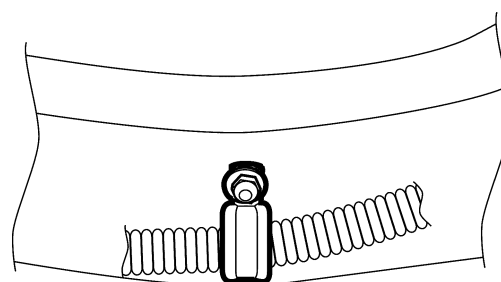

123 450

R/P cab

Cable routing on right step well plate, R and P cabs.

Fit the intake cables to the mounting plate and the new plastic cover for the step well.

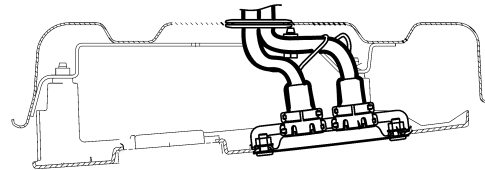
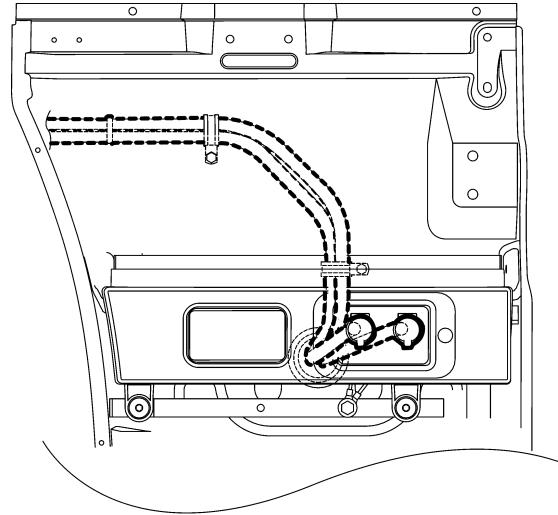

121 910

Cable routing on the inside of the step well plate, past the air filter container. Route the engine heater cable over the frame member to the engine. Route the cab socket cable together with the rest of the wiring along the frame member to the front cab attachment.

Note: Clamp the cables to avoid chafing.

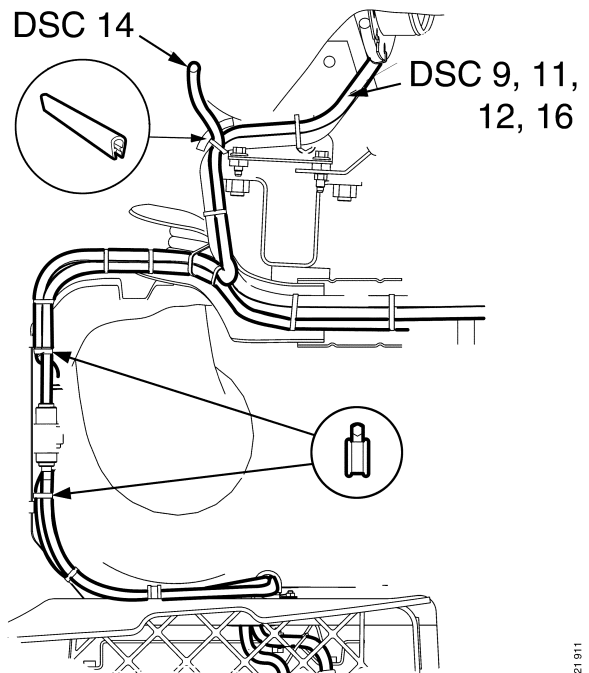

121 911

T cab

Remove the service step cover.

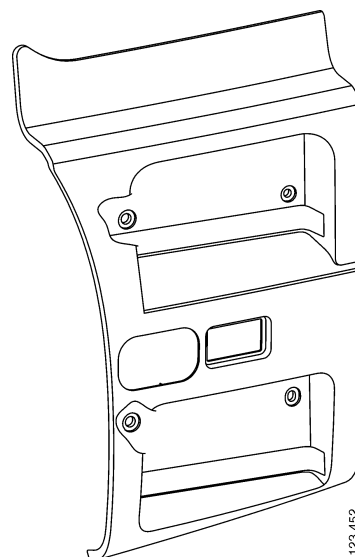

Mark the hole for the intake cable bracket from the rear. Cut out the hole using a pad saw.

Note: Use the pad saw on low speed to prevent the plastic from melting directly behind the sawing blade.

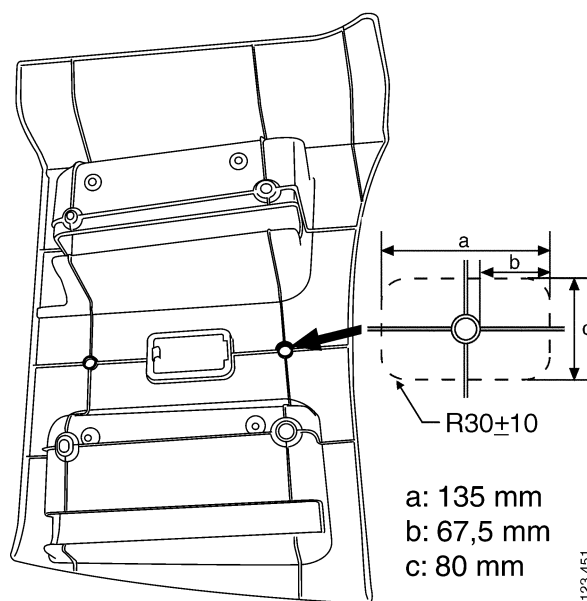

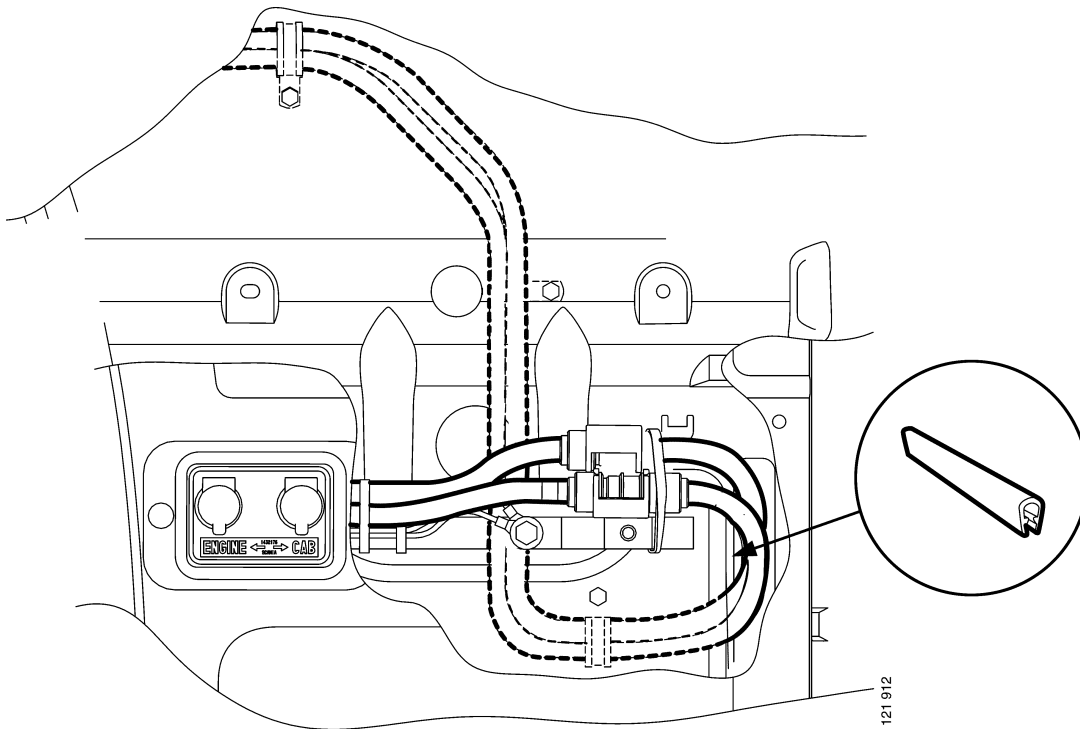

Cable routing on right service step plate, T cab.

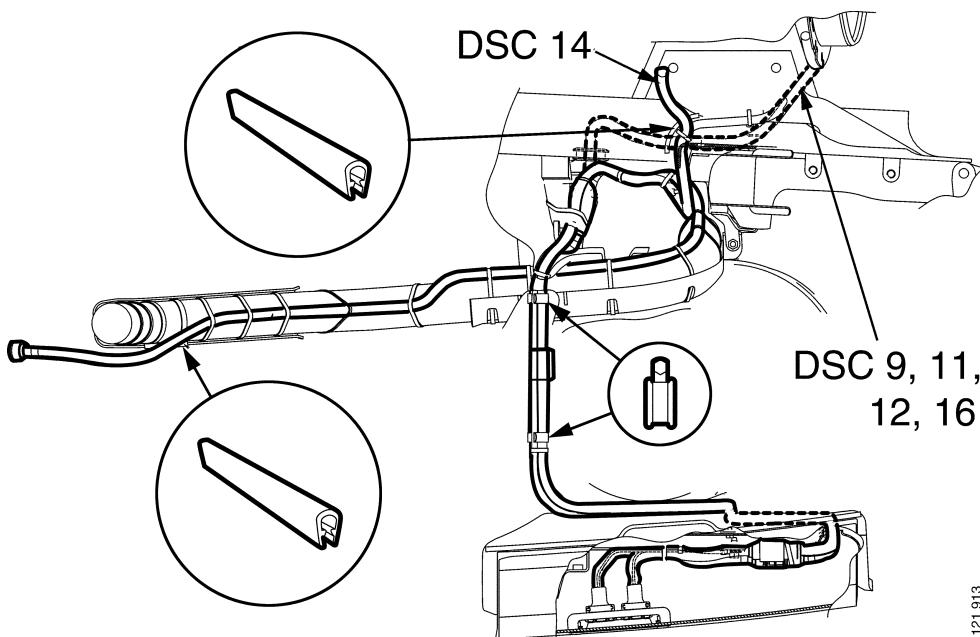

Cable routing on the inside of the service step plate, past the air filter container. Route the engine heater cable over the frame member to the engine. Route the cab socket cable together with the rest of the wiring along the frame member to the front cab attachment.

Cab socket cable

Cab attachment, front, R/P cab

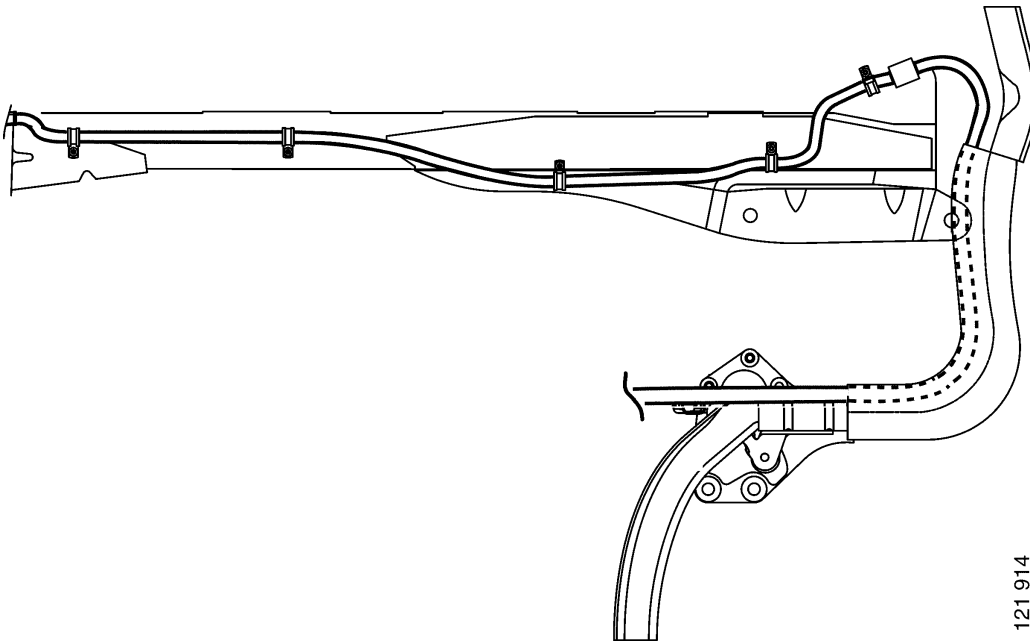

Cab attachment, front, T cab

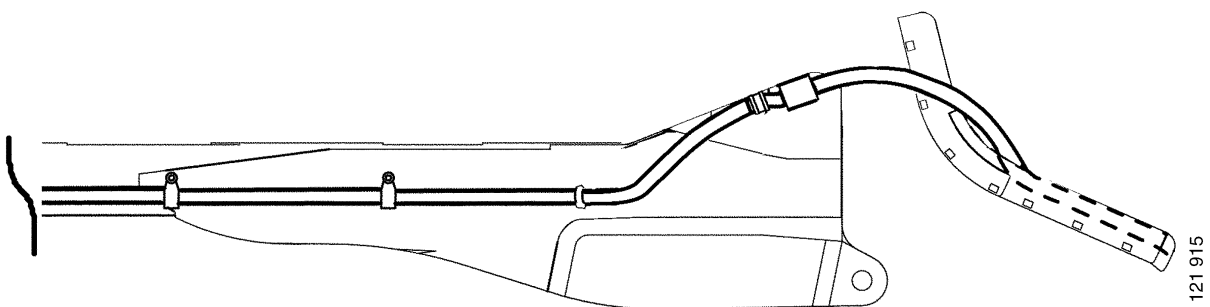

Route the cab socket cable under the cab along the right cab beam.

CR-14

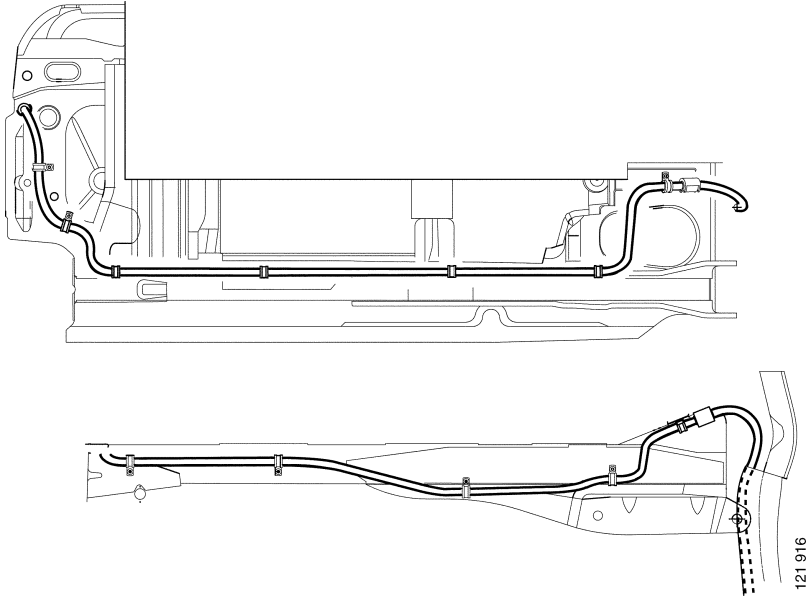

CT-14

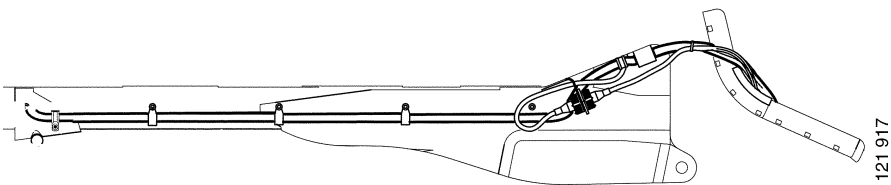

CP-14

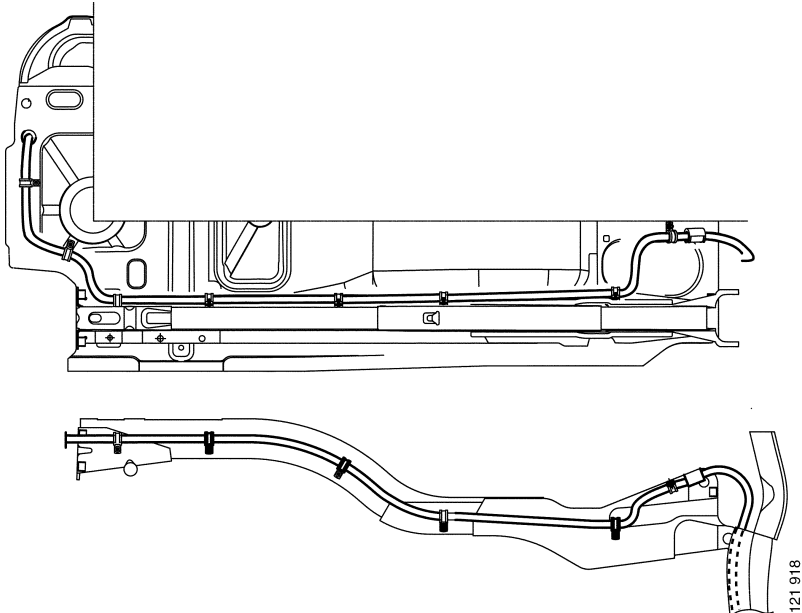

CR-19

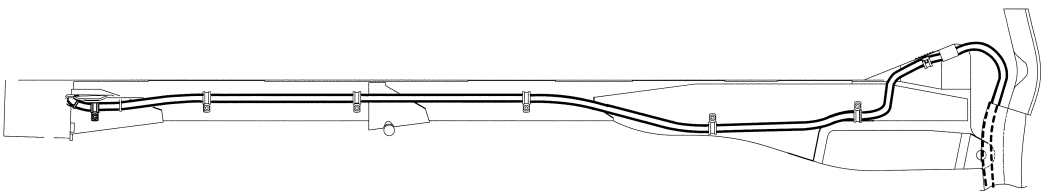
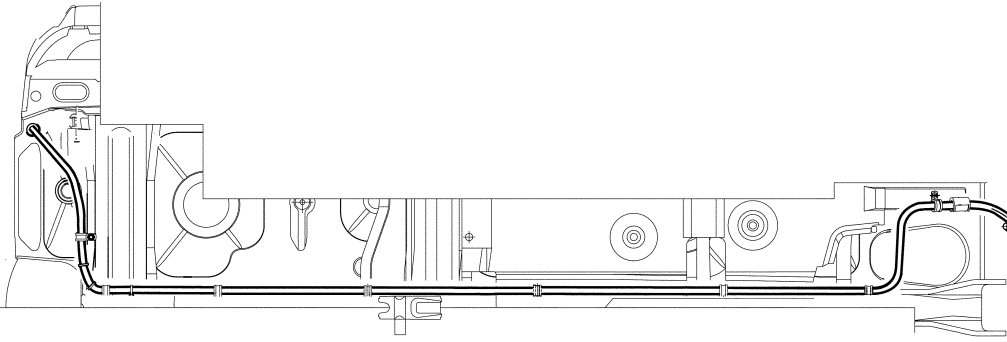

CP-19

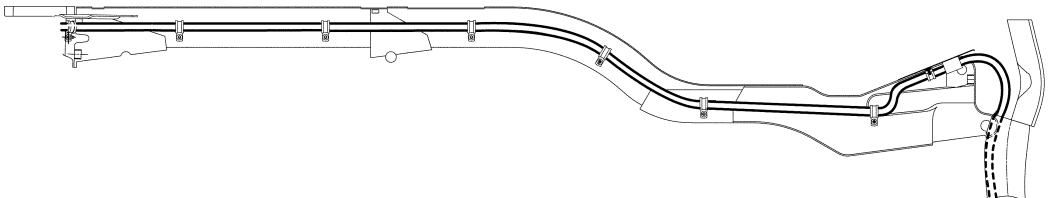
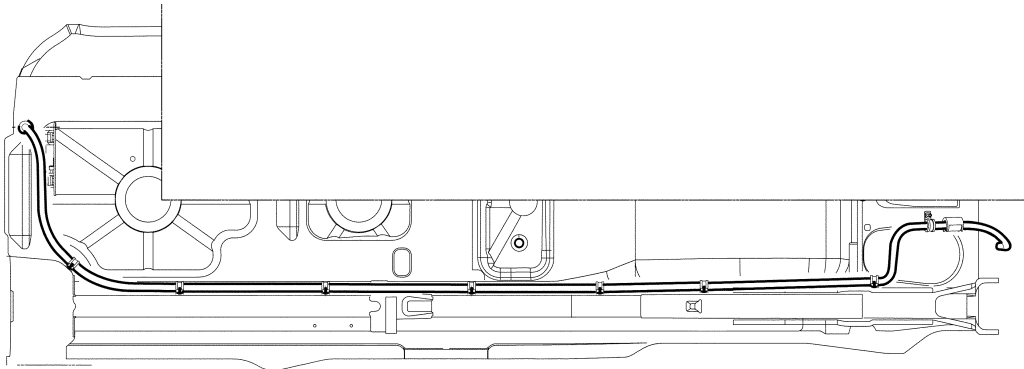

CT-19

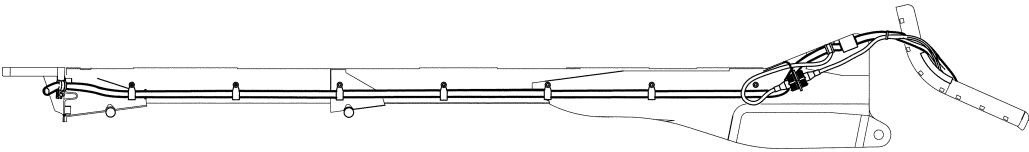
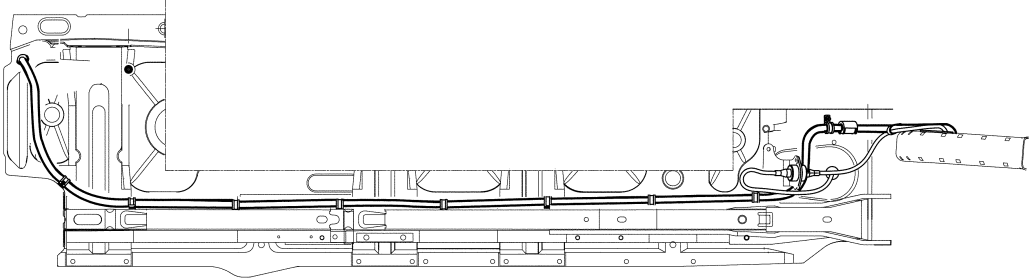

121 921

CP-28/31, CrewCab

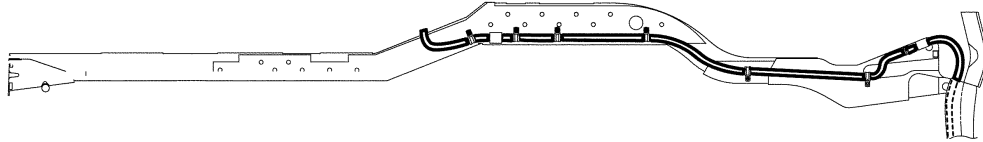
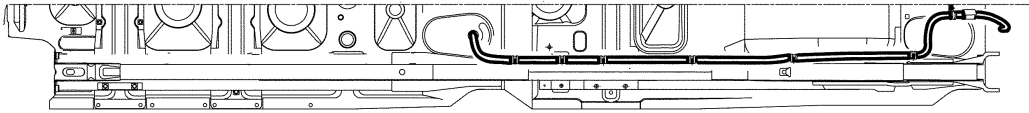

121 922

Cab socket

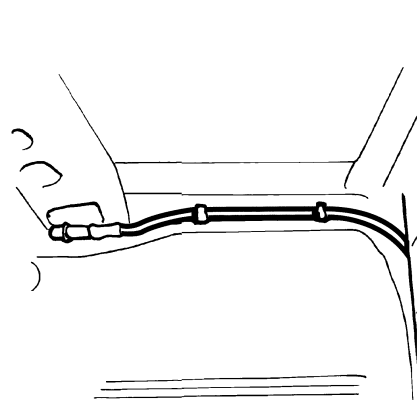
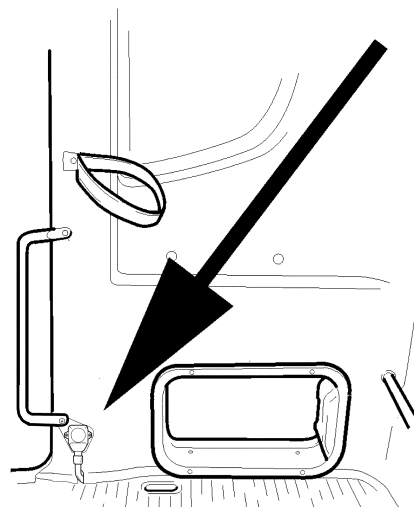

C -14

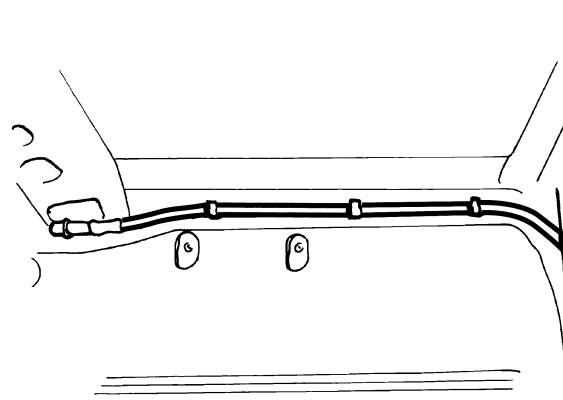

C -19

122 825

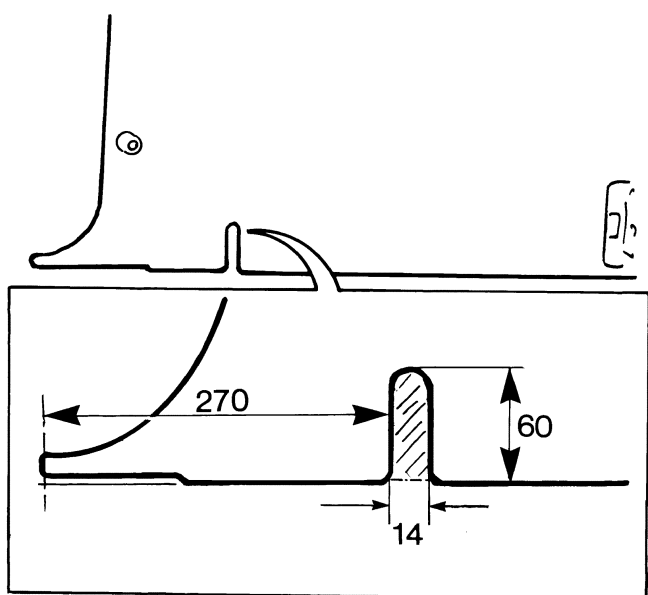

122 826

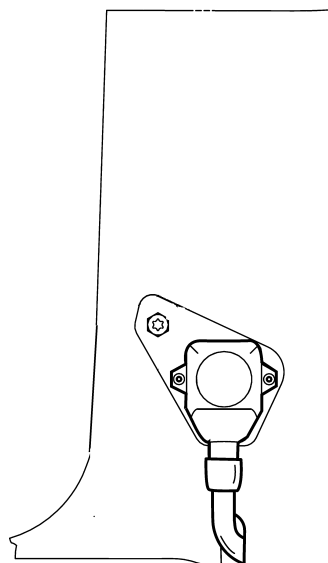

122 827

Engine heater element

Clean the contact surfaces for the engine heater elements thoroughly to avoid leakage. Remember the gasket between the engine block and the engine heater element.

Clamp the cable thoroughly to prevent it from breaking or from chafing. Remember to allow the cable some movement in the cross-over between the engine and the chassis. This is necessary during engine movements in relation to the chassis under load.

9 litre engine

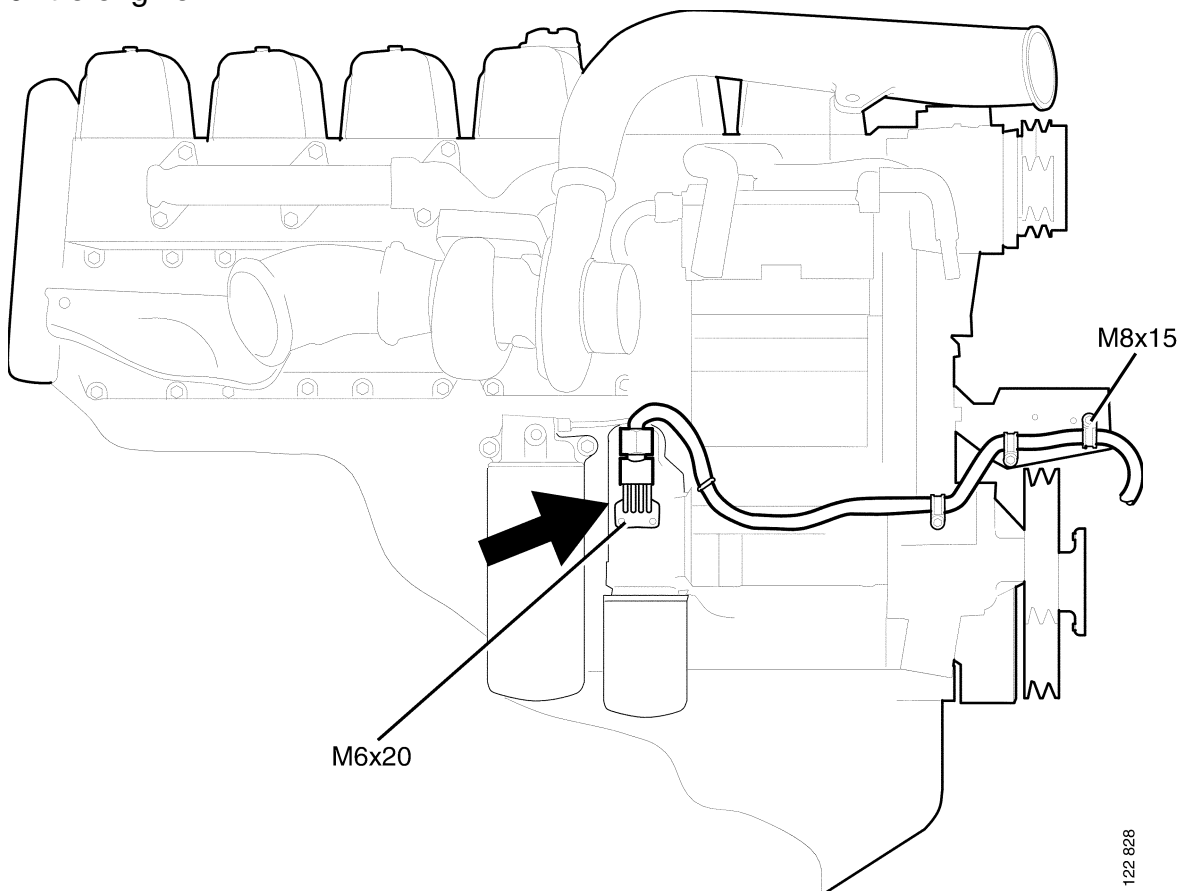

11 and 12 litre engines

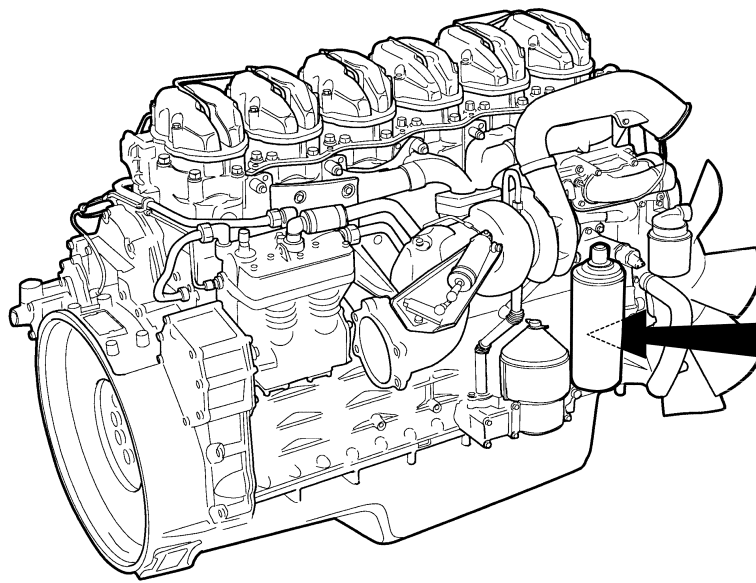

122 829



122 830

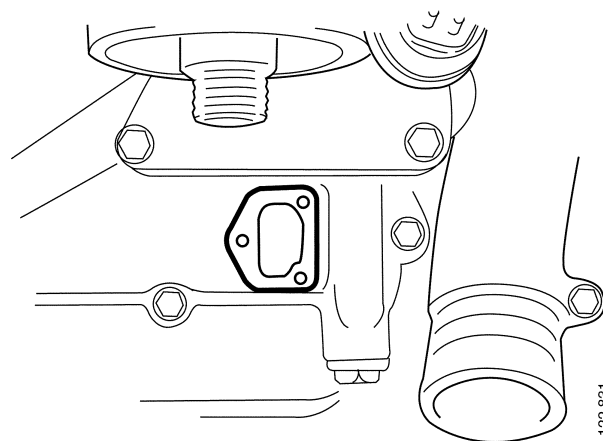

122 831

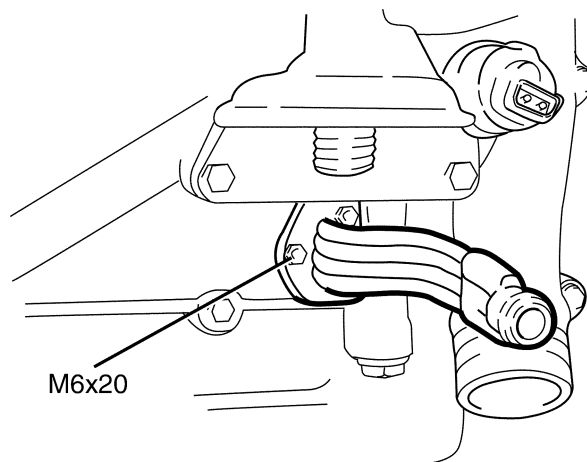

122 832

14 litre engine

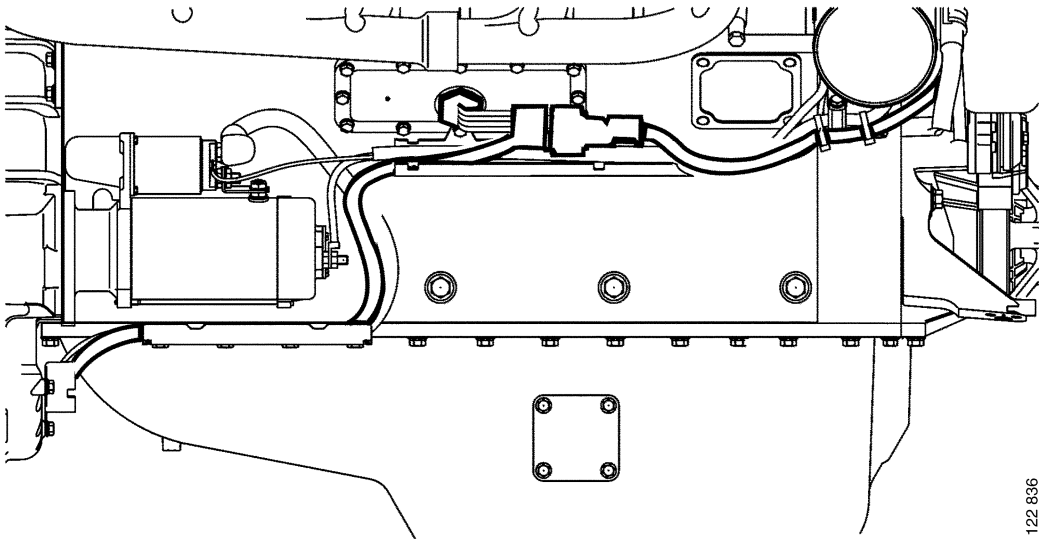

122 836

Right-hand side

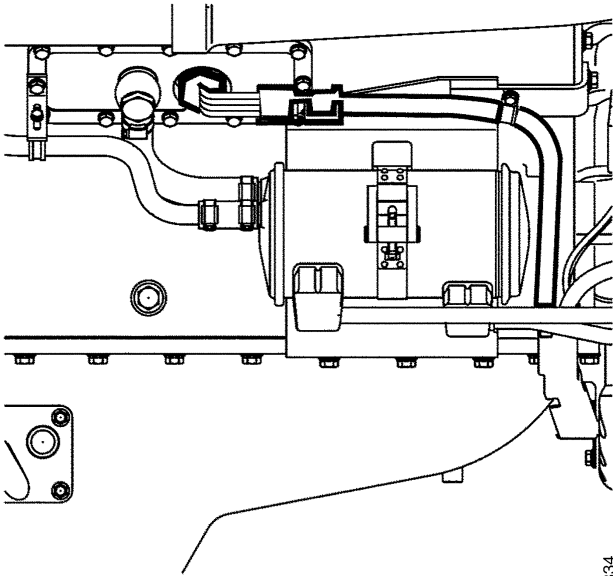

122 834

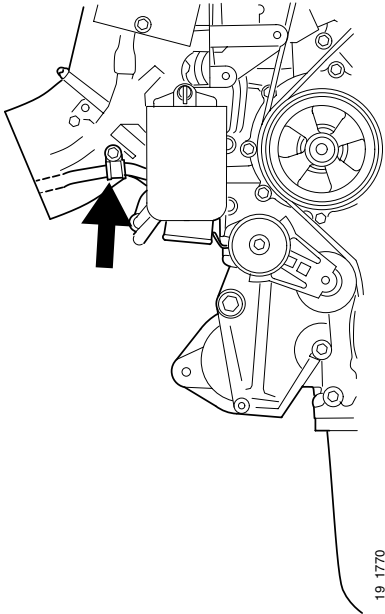

19 1770

Left-hand side

Clamp on the engine front

16 litre engine

