

SCANIA

01:00-03

Issue 3 en

Measurement kit 99 362

Work description

99 362

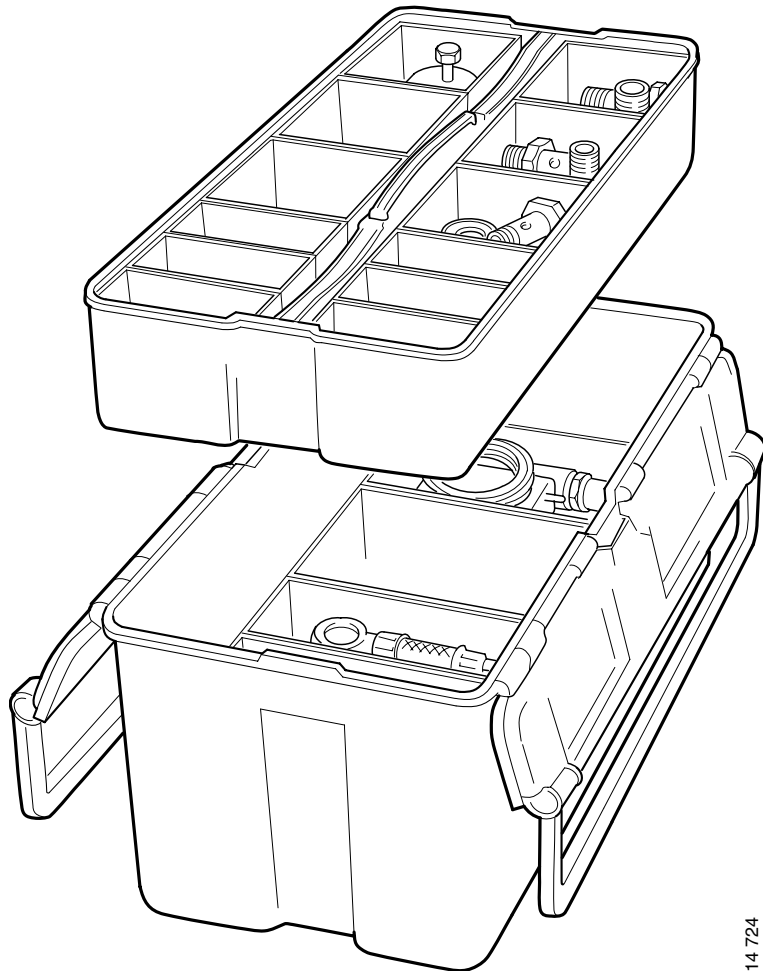

114 724

Contents

General	3
Transducer	3
Charging pressure	5
Measuring oil pressure	8
Measuring fuel pressure	10
Measurement kit contents	13

General

Using measurement kit 99 362 and a standard multimeter, it is possible to check the charging, oil and fuel pressure of an engine. It is also possible to measure the pressure in the Scania retarder system by also using test connection 99 378. Refer to booklet 10:05-08, Scania retarder – troubleshooting.

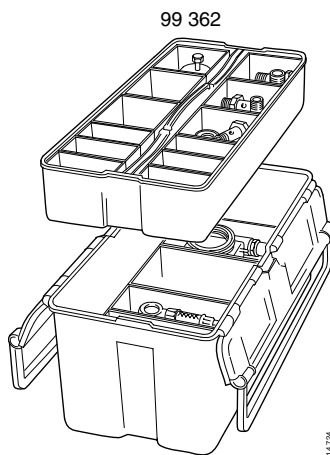

Transducer

The transducer and its pressure sensor supply the multimeter with a DC voltage value corresponding to a pressure, $0.1 \text{ V} = 100 \text{ kPa} = 1 \text{ bar}$.

The transducer is supplied power from its own separate 9-volt battery. When the battery voltage is too low, a small lamp, marked LOW BAT, comes on.

To renew the battery, press on the battery lid while sliding it upwards. Then remove the battery and fit a new one. Do not pull on the cables.

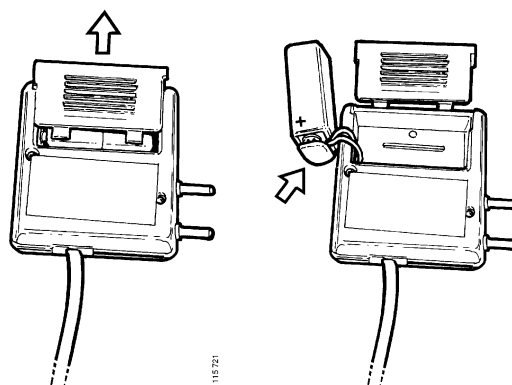

The transducer can measure kPa, cmHg, inHg and psi. The measuring range is selected by means of small toggle switches located behind the transducer battery. The toggle switches have numbers 1 to 4 starting from the middle.

Newer versions of the transducer lack toggle switches and have preset measuring ranges. The pressure sensor is then set to indicate the result in kPa. The pressure sensor supplies the multimeter with a voltage in mV. $100 \text{ mV} = 0.1 \text{ V} = 100 \text{ kPa} = 1 \text{ bar}$

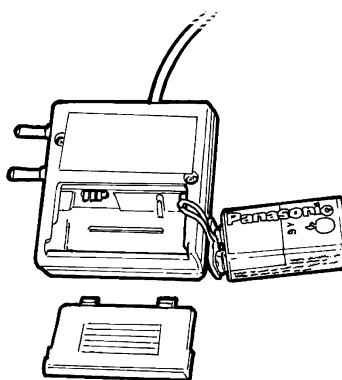

	SW 1	SW 2	SW 3	SW 4
kPa	ON	OFF	OFF	OFF
cmHg	OFF	ON	OFF	OFF
inHg	OFF	OFF	ON	OFF
psi	OFF	OFF	OFF	ON

Connect the transducer to the multimeter COM and V/Ohm sockets.

Connect the measurement kit unions and hoses for the respective measurement to the transducer.

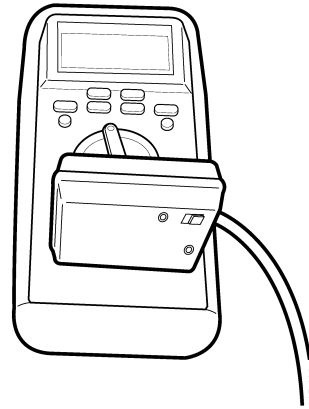

Switch on the multimeter and set it to DCV (DC voltage). Switch on the transducer and check that the multimeter reading is 0.0 V in the idle state. If the multimeter reading deviates from the above, reset the multimeter by turning the adjusting screw on the transducer, marked ZERO. The multimeter may also be reset by pressing the switch marked Relative, if available.

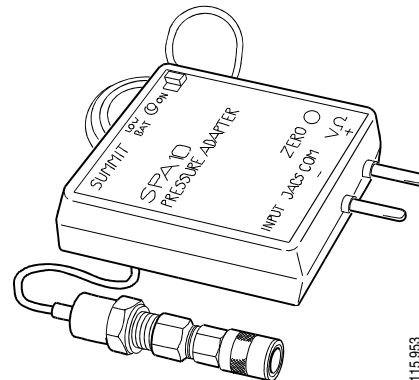

Measuring charging pressure

Without EDC

Detach the smoke limiter connection from the injection pump.

Remove the union and fit a new one from the measurement kit for parallel connection of the measuring equipment.

With EDC

Detach the charge pressure sensor from the induction pipe.

Connect the measuring equipment adapter between the induction pipe and the charge pressure sensor.

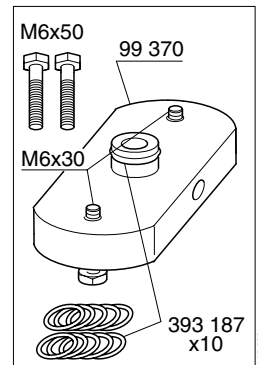
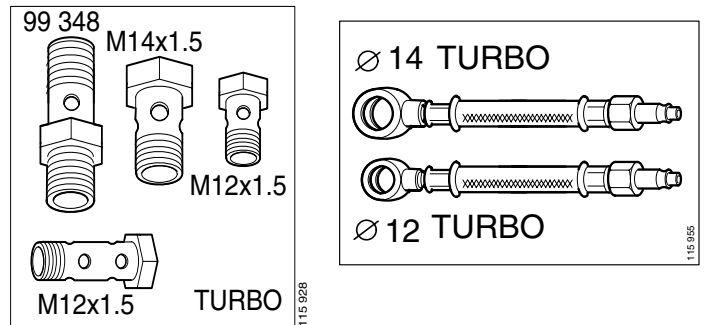

9 litre engine

Without EDC

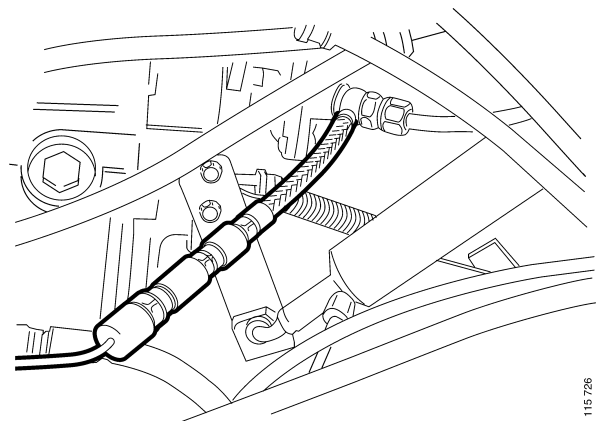

With EDC

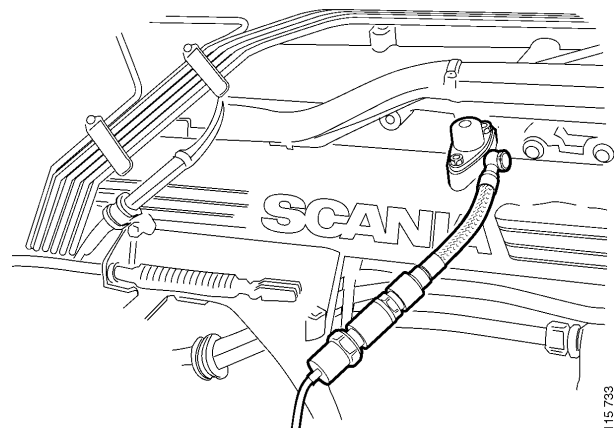

11 and 12 litre engines

Without EDC

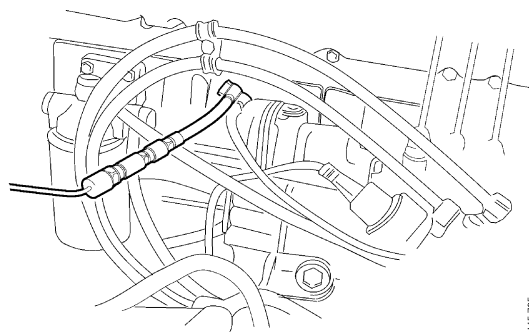

115 725

With EDC

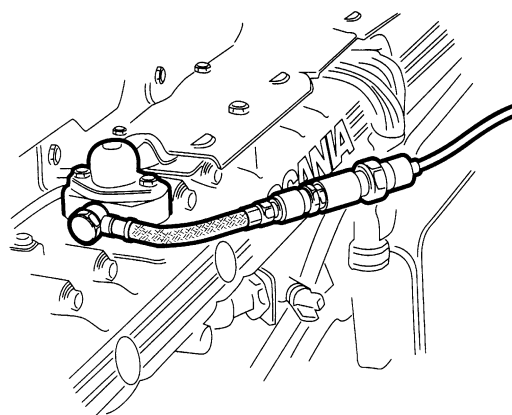

115 726

14 litre engine

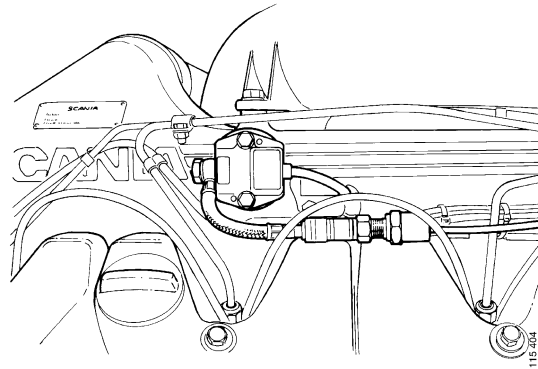

16 litre engine

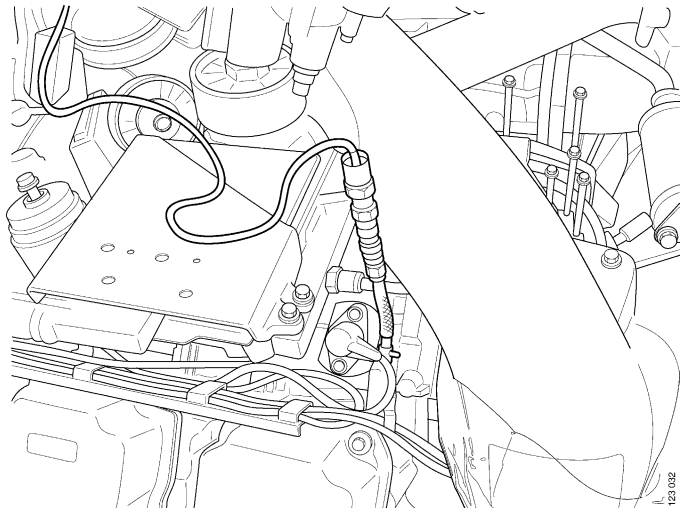

Measuring oil pressure

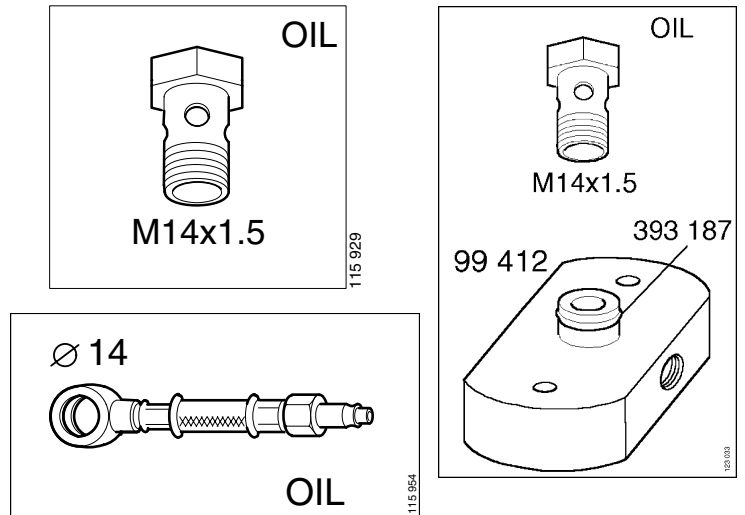

9 litre engine

Disconnect the connector from the oil pressure sensor. Remove the oil pressure sensor and fit a union from the measurement kit along with the measuring equipment.

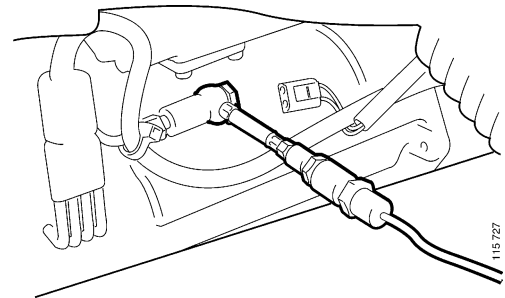

11 and 12 litre engines

Earlier version

Disconnect the connector from the oil pressure sensor. Remove the oil pressure sensor and fit a union from the measurement kit along with the measuring equipment.

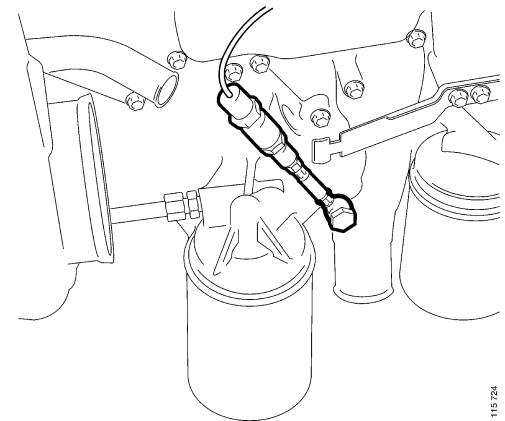

Later version

Fit the measuring equipment adapter as illustrated.

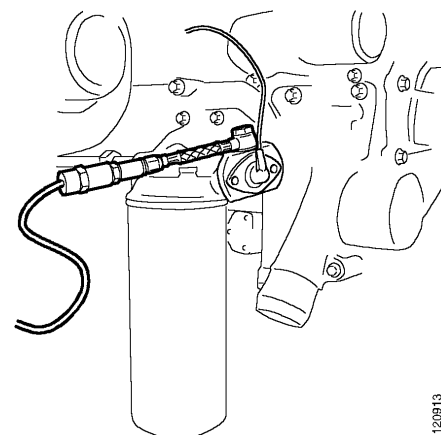

14 litre engine

Remove the plug next to the oil pressure sensor and fit a union from the measurement kit along with the measuring equipment.

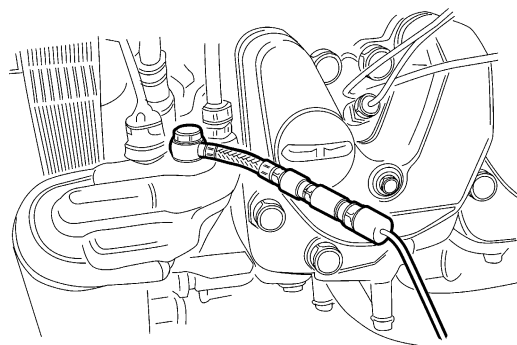

16 litre engine

Detach the oil pressure sensor.

Connect the measuring equipment adapter between the cylinder block and the oil pressure sensor.

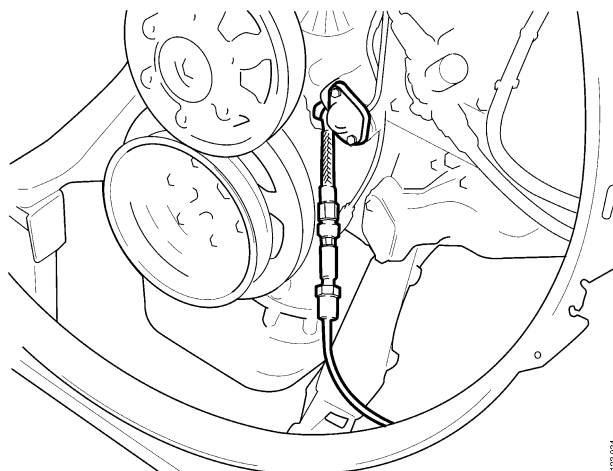

Measuring fuel pressure

Remove the union from the fuel filter and fit a new union from the measurement kit with measuring equipment connection.

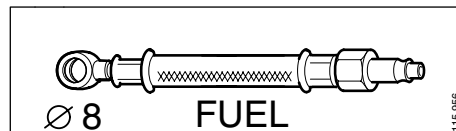
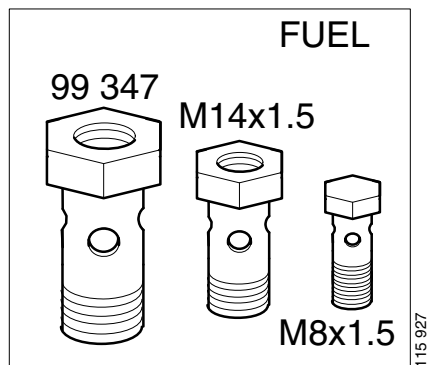

9 litre engine

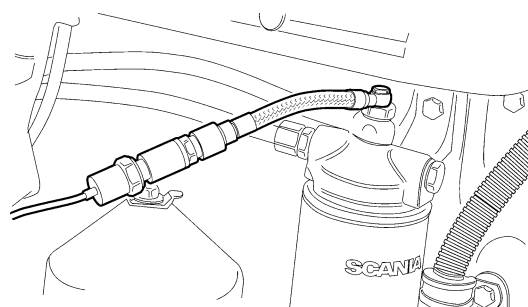

11 and 12 litre engines

- 11 and 12 litre engines

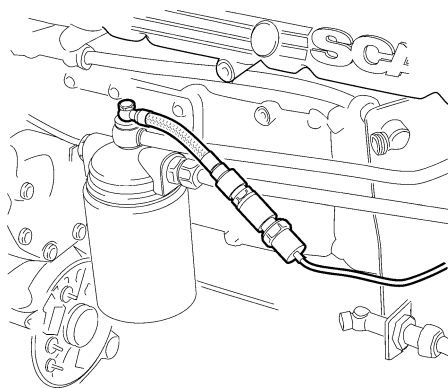

- 12 litre engine, HPI

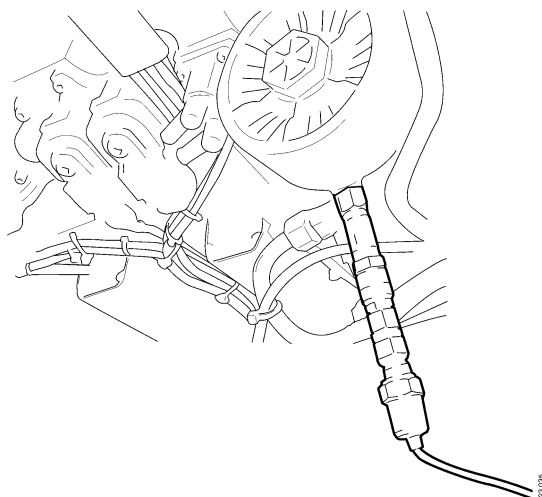

- 12 litre engine, HPI. Vehicles with double front axles or mechanically controlled tag axle. Replace the straight union with an angled one. The angled nipple is originally found on the fuel filter of the 16 litre engine.

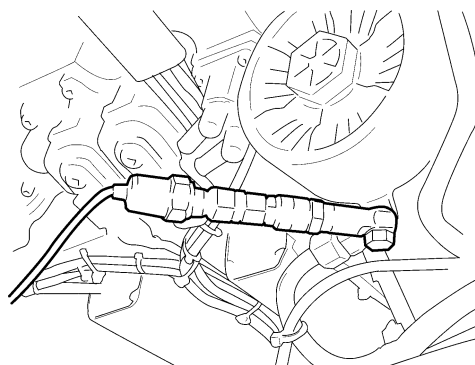

12 litre engine, bus

Fuel manifold connection on same side as the engine belt transmission.

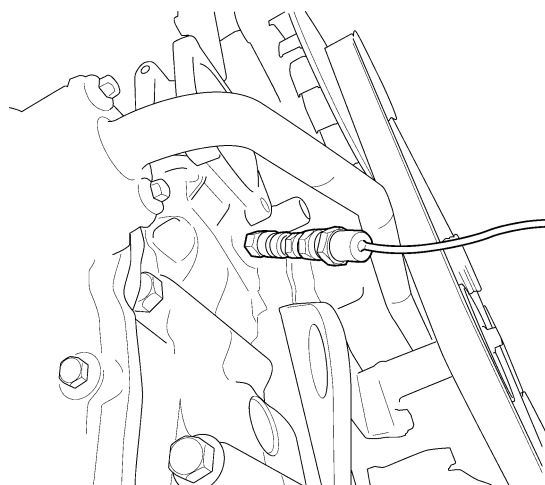

14 litre engine

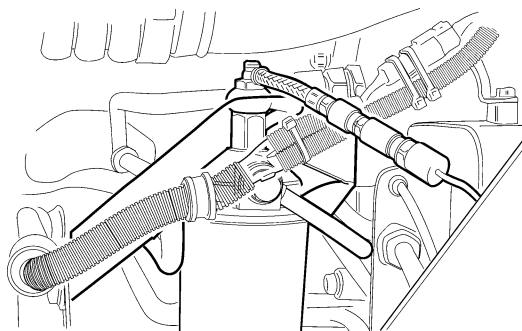

116 251

16 litre engine

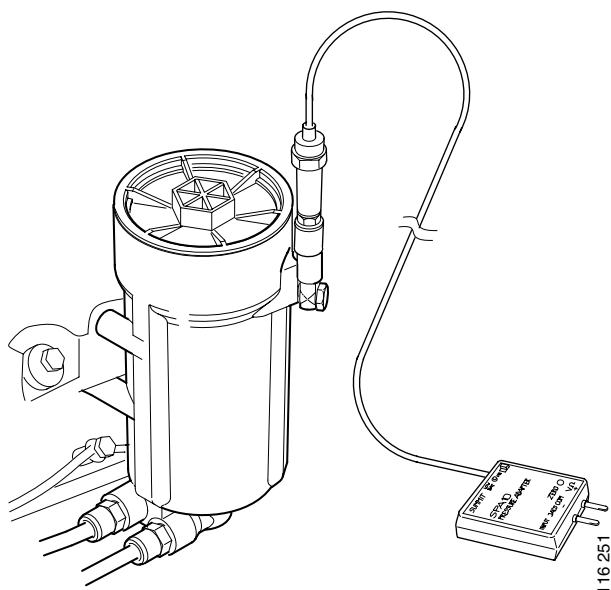

116 251

Fuel filter connection

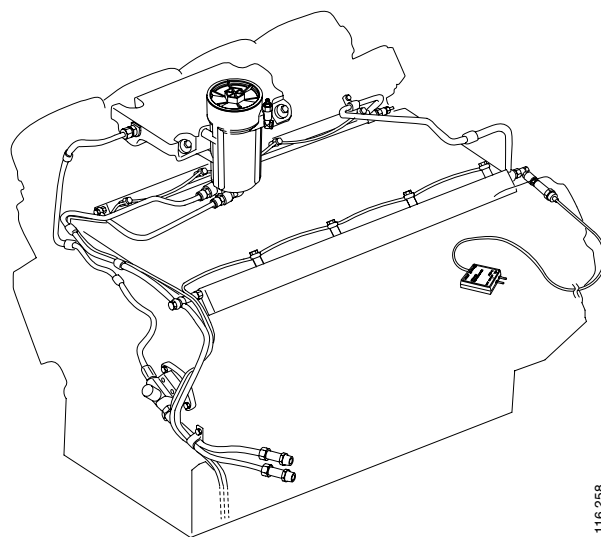

116 258

Fuel manifold connection

Measurement kit contents

This sheet is delivered along with the measurement kit

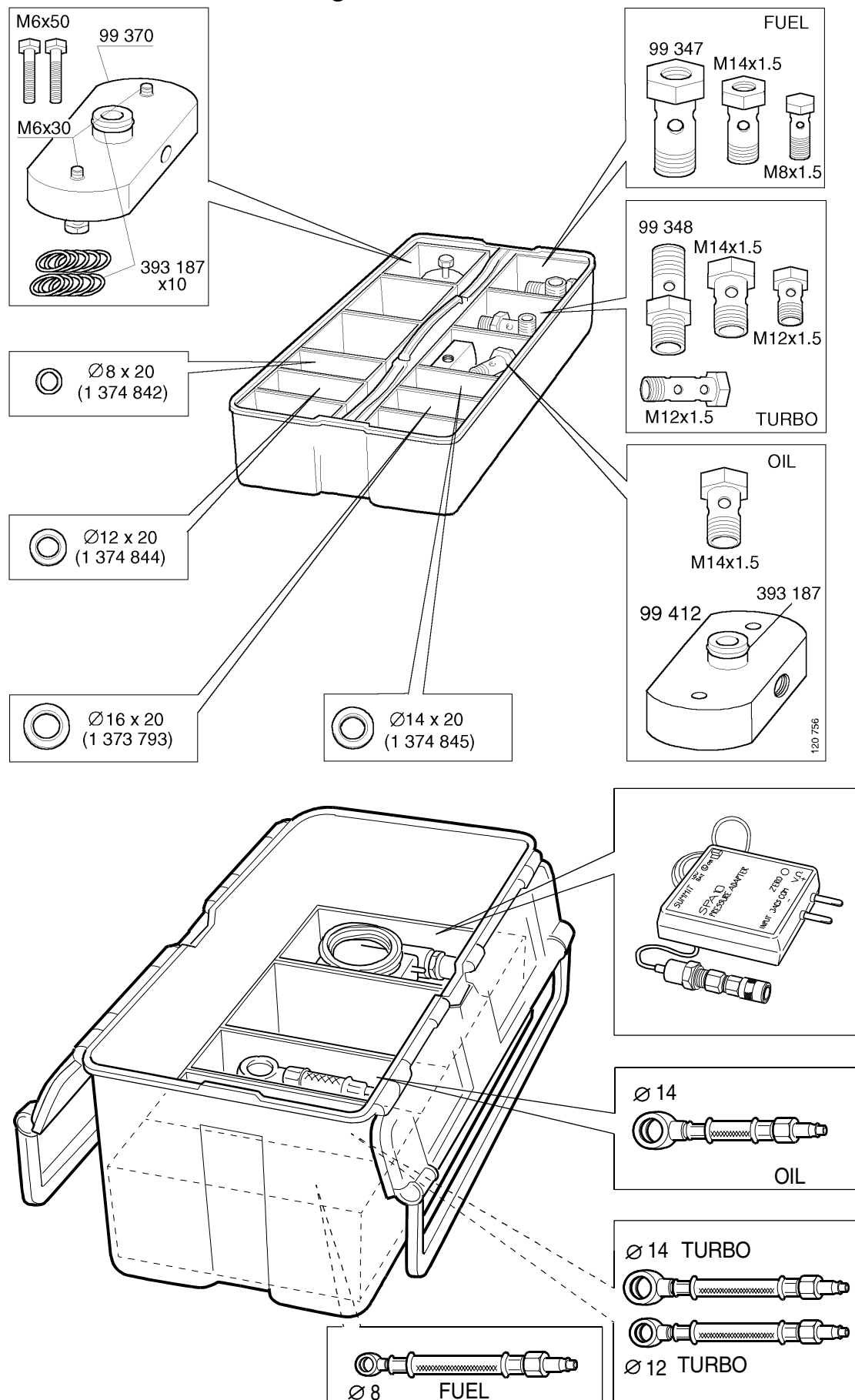

115 102

This sheet is delivered along with the measurement kit

BRIEF INSTRUCTION FOR PRESSURE MEASUREMENT KIT 99362

1. Connect the pressure adapter to any standard multimeter with COM and V/Ohm terminals.
2. Turn multimeter selection switch to position DCV.
3. Connect transducer to the system (oil, turbo pressure or fuel supply). Use suitable parts from connector kit, depending of engine type.
4. Zero the adapter by using potentiometer "ZERO". If the multimeter has Relative Mode it's possible to use that function to zero the adapter.
5. Start engine and read pressure on multimeter display. 0,1 V = 1 bar.

CONNECTIONS

SYSTEM	ENGINE	CONNECTOR HOSE	BANJO SCREW
Oil	9,11,12,14	60mm/banjo 14mm	M14x1,5mm (812390)
Oil	12,16	60mm/banjo 14mm	M14x1,5mm (812390) Adapter 99412
Turbo	9 (No EDC)	100mm/banjo 12mm	M12x1,5mm (99348)
Turbo	11 (No EDC)	100mm/banjo 14mm	M14x1,5mm (812390)
Turbo	12 (No EDC)	100mm/banjo 12mm	M12x1,5mm (343579)
Turbo	9,11,12,14,16	100mm/banjo 12mm	M12x1,5mm (812389) Adapter 99370
Fuel	9,11	100mm/banjo 8mm	M14x1,5mm(1374042)+M8x1,5 (17146)
Fuel	12,14	100mm/banjo 8mm	M16x1,5mm (99347)+M8x1,5 (17146)
Fuel	12,16	Transducer connector	—

PRESSURE ADAPTER SPECIFICATION

UNIT	OUTPUT	RANGE	ACCURACY
Psi	1 mV=1 Psi	0,5-350	+/- 1% of reading (+/- 0,3 Psi)
		350-500	+/- 5% of reading (+/- 1,0 Psi)
KPa	1 mV=1 kPa	3,447-2413	+/- 1% of reading (+/- 2,1 kPa)
		2413-3447	+/- 5% of reading (+/- 7 kPa)

DIP SWITCH SELECT/BATTERY SPECIFICATIONS

Remove battery cover on rear side. Remove battery to find switch numbers. Follow the table below to make choice of units. Change battery if "LOW BAT" indicator on front side illuminate.

	SW 1	SW 2	SW 3	SW 4
kPa	ON	OFF	OFF	OFF
cmHg	OFF	ON	OFF	OFF
inHg	OFF	OFF	ON	OFF
Psi	OFF	OFF	OFF	ON

Battery specification: 9V NEDA 1604, 6F22 Consumption: approx. 6 mA

115 837