

**SCANIA**

**03:02-02**

Issue 3 en

# EDC MS5 for injection pump

## Work description

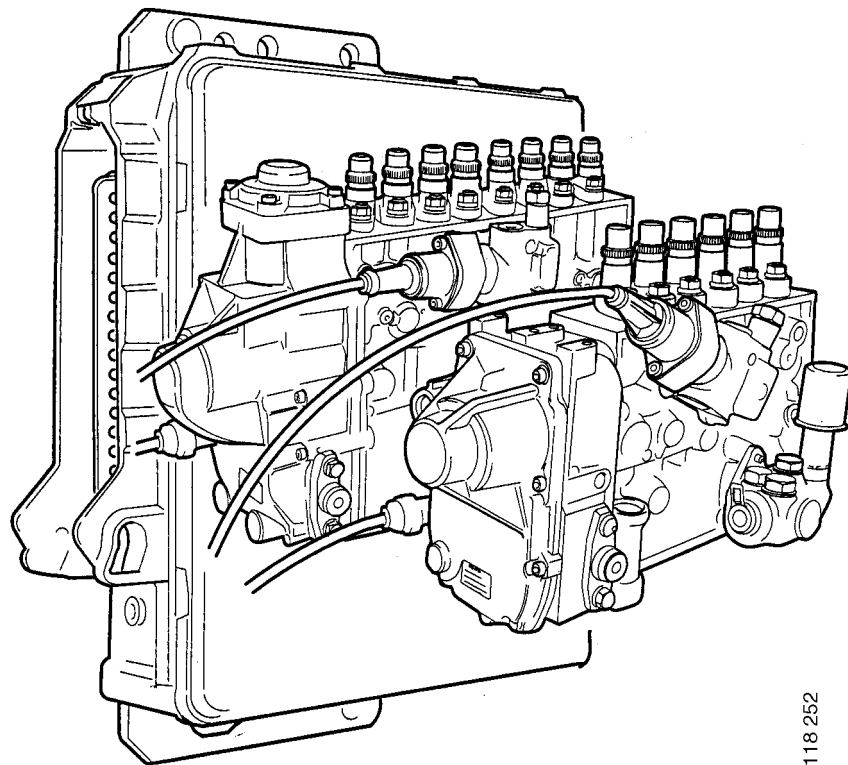

118 252

# Contents

Renewing the EDC control unit .....	3
Adjusting idling speed	
With control for cruise control .....	5
Without control for cruise control .....	5
Scania Programmer .....	11
Activating functions .....	13
Example of programming three fixed speeds .....	15
External engine control .....	17

# Renewing the EDC control unit

Consider the following points when renewing the EDC control unit.

**IMPORTANT!** The control unit can be damaged if it is still supplied with voltage while being unplugged. The ignition must therefore be turned off using the starter key and the EDC indicator lamp extinguished before the control unit is removed.

Perform the following procedure after renewing the control unit.

- 1 Carry out the necessary programming with Scania Programmer.
- 2 Start the engine. Check and then erase fault codes with Scania Diagnos.



# Adjusting idling speed

## With control for cruise control

How to adjust idling speed with the control for cruise control is described below. The idling speed can be adjusted between 500 and 700 rpm.

The general rule is that the idling speed should be set at the lowest engine speed where the engine still runs smoothly.

**Note:** If the idling speed cannot be adjusted as described below it may be because Scania Programmer has been selected in Scania Programmer for adjusting the idling speed. Select control for cruise control instead.

- 1 Run the engine until it reaches normal operating temperature.
- 2 Put the control for cruise control in ON position.
- 3 If the vehicle is a bus — make sure the switch for Fixed engine speed is off.
- 4 Depress and hold down the brake pedal until the following points have been completed.
- 5 Press RES for at least 3 seconds. The engine speed will now be 500 rpm —this is the basic setting.

**IMPORTANT!** Adjust the idling speed until the lowest speed is attained at which the engine runs smoothly. Never set a higher idling speed than 550 rpm.

- 6 Press ACC to increase the idling speed or RES to decrease it. Pressing once corresponds to 10 rpm.
- 7 Press RES for at least 3 seconds after

setting the lowest idling speed at which the engine will run smoothly. The idling speed has now been adjusted and you can release the brake pedal. The vehicle will retain this idling speed until someone sets a different idling speed.

## Without control for cruise control

The idling speed can still be adjusted even if the vehicle does not have a control for cruise control. This can be done using an adapter cable or Scania Programmer.

Idling speed can be adjusted using Scania Programmer on control units with the following hardware numbers only. 1 413 154. The hardware number can be read using Scania Programmer.

The following page describes how to make an adapter cable and how to use it to adjust the idling speed.

## Adapter cable

The following components will be required for making the adapter cable:

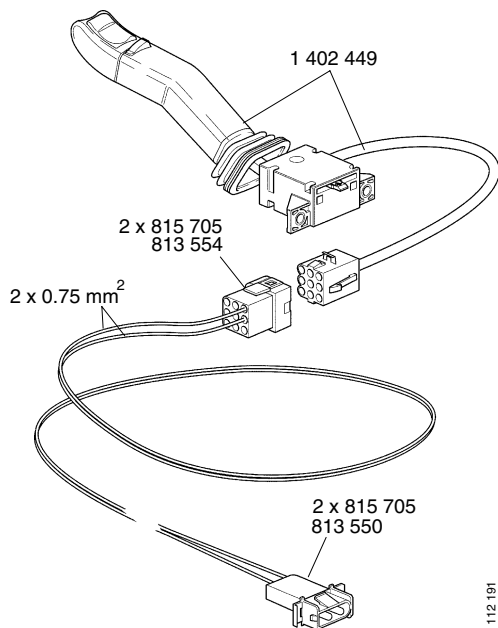

Description	Part no.	Qty	Note
Switch	1 402 449	1	Indicator stalk with control for cruise control
Electric cable	-	2	0.75 mm <sup>2</sup> , length approx. 2 m
Contact housing	813 554	1	9-pin
Contact housing	813 550	1	2-pin
Round pins	815 705	4	3.5 mm

Assemble the adapter cable as shown in the sketch below.

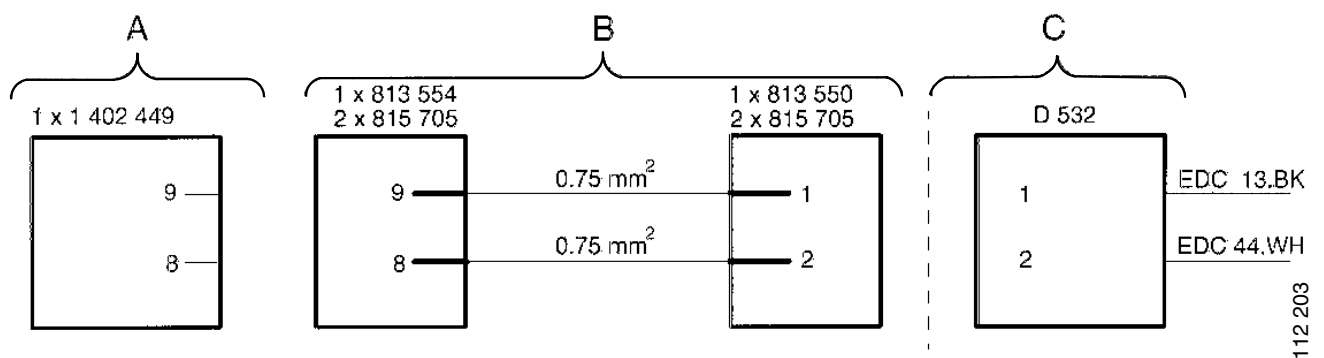

*A = indicator stalk with control for cruise control*

*B = two connectors and two cables*

*C = connector in the central electric unit*

## Adjusting idling speed using the adapter cable

Adjust the idling speed as described below using the adapter cable.

**Note:** If the idling speed cannot be adjusted as described below it may be because Scania Programmer has been selected in Scania Programmer for adjusting the idling speed. Select control for cruise control instead.

- 1 Run the engine until it reaches normal operating temperature.
- 2 Apply the parking brake.
- 3 Select neutral.
- 4 Switch off the engine.
- 5 Open the hatch in the ceiling that carries the central electric unit.
- 6 Remove the resistor from the contact housing that is hanging approx. 10 cm from the connector marked EDC 9, C508.
- 7 Plug in the adapter cable contact housing to the contact housing from which you removed the resistor.
- 8 Start the engine.
- 9 Put the control for cruise control in ON position.
- 10 Make sure the switch for Fixed engine speed is off.
- 11 Depress and hold down the brake pedal until the following points have been completed.
- 12 Press RES for at least 3 seconds. The engine speed will now be 500 rpm –this is the basic setting.

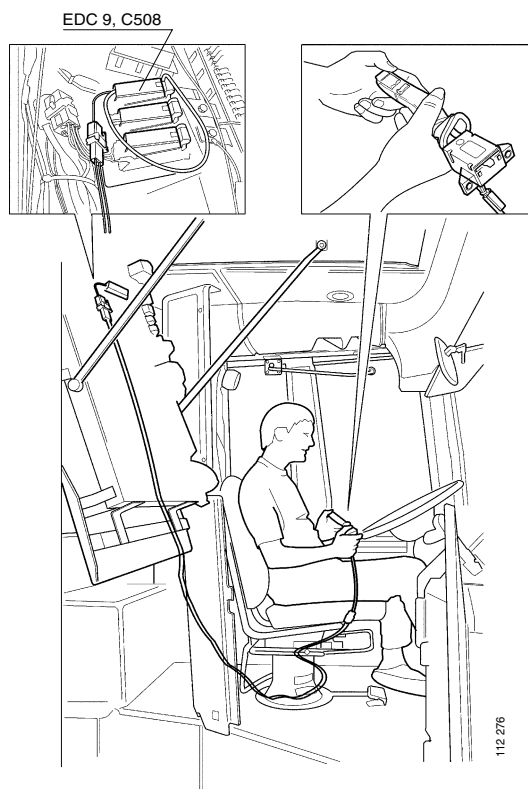

**IMPORTANT!** Adjust the idling speed until the lowest speed is attained at which the engine runs smoothly. Never set a higher idling speed than 550 rpm.

- 13 Press ACC to increase the idling speed or RES to decrease it. Pressing once corresponds to 10 rpm.
- 14 Press RES for at least 3 seconds after setting the lowest idling speed at which the engine will run smoothly. The idling speed has now been adjusted and you can release the brake pedal. The vehicle will retain this idling speed until someone sets a different idling speed.
- 15 Turn off the power supply with the starter key. If this is not done, fault code 21 will be set when the next step is carried out.
- 16 Remove the adapter cable and reconnect the resistor you removed.



# Scania Programmer

The following procedures can be carried out using Scania Programmer.

- Setting the Limited hand throttle function.
- Setting the Fixed engine speed function.
- Set whether the following functions can be used for engine speed control while a gear is engaged: Normal hand throttle, Limited hand throttle, Raised idling and Fixed engine speed.
- Setting maximum vehicle speed.
- Setting a second vehicle speed limit
- Selecting type of regulator (RQ or RQV)
- Adjusting idling speed or selecting to adjust it with the control for cruise control instead.

It is the control unit hardware number that determines whether the above procedures can be performed. See the table on the next page. The control unit hardware number can be read using Scania Programmer.

Parameters	Control unit hardware number			
	1 382 152	1 383 003	1 398 849, 1 427 842	1 413 154
Limited hand throttle				
- maximum torque	SP	SP	SP	SP
- maximum engine speed	-	-	SP	SP
- accelerator pedal (disengaged or not)	-	-	-	SP
Fixed engine speed (maximum torque and constant engine speed)	SP	SP	SP	SP
Maximum vehicle speed	SP	SP	SP	SP
Speed limiter 2	-	-	SP	SP
Type of regulator	-	-	SP	SP
Idling speed adjustment	-	-	-	SP
Prevention of engine speed control when gear engaged	-	-	-	SP

SP means that the parameter can be set using Scania Programmer.

# Activating functions

This section describes how to activate the following functions.

- Emergency stop
- Limited hand throttle
- Fixed engine speed
- Raised idling speed
- Torque limiters 1, 2 or 3
- Speed limiter 2

All the functions except Speed limiter 2 are activated by earthing — in different combinations — certain EDC control unit pins. The function Speed limiter 2 is activated by applying a +24 V voltage to EDC control unit pin 50.

On trucks, the pins are earthed via connector C107, which is located under the central electric unit. It is a blue 5-pin connector complete with both contact housings factory fitted.

The illustration shows the connection between the control unit and connector C107. The pins to be earthed to activate each function are shown on the next page.

Use the following parts when connecting:

- Cable terminal (pin), part no. 199 950
- Cables with cross-section 0.75 mm<sup>2</sup>

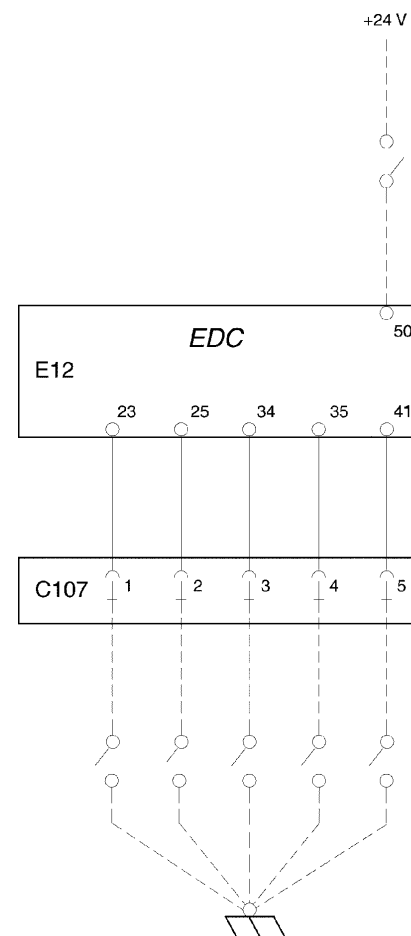

b1109447

*Connection diagram for special functions on trucks. For busses — refer to wiring diagram in Workshop Manual group 16.*

The pins in the connector to which the cables should be routed in order to activate each special function are shown below.

The table applies to trucks only. Refer to the bus wiring diagram if you are connecting cables on a bus.

<b>Special function</b>	<b>Connector pin</b>	<b>Corresponding pin on the EDC control unit</b>
Emergency stop	C107, pin 2	25
Limited hand throttle	C107, pin 1	23
Raised idling speed	C107, pin 5	41
Fixed engine speed	C107, pin 1+5	23 + 41
Torque limiter 1	C107, pin 4	35
Torque limiter 2	C107, pin 3	34
Torque limiter 3	C107, pin 3+4	34 + 35
Speed limiter 2	-	50

## Example of programming three fixed engine speeds

Certain types of bodywork may require one or more pre-set fixed engine speeds.

An example of how to pre-set three fixed engine speeds is shown here. Switching between them can be achieved using a switch that earths the pins.

The control for cruise control must be ON before the settings can be made.

### Engine speed 1

Set engine speed 1 with the Raised idling speed function using the control for cruise control.

Engine speed range 500 - 800 rpm

Pin 41 is earthed.

### Engine speed 2

Set engine speed 2 with the Limited hand throttle function using the control for cruise control.

Engine speed range 500 -2000 rpm

Pin 23 is earthed.

### Engine speed 3

Set engine speed 3 with the Fixed engine speed function. This function is programmed into the control unit using a PC and Scania Programmer.

Engine speed range 600 -2000 rpm

Pins 23 and 41 are earthed.



# External engine control

In certain cases, it may be necessary to operate the engine speed control externally using controls corresponding to the cruise control ON, OFF, ACC, RET and RES. The external control can be connected as shown in the wiring diagram External engine control, see group 16 in the Workshop Manual.

**IMPORTANT!** The connection must be made exactly as shown in the wiring diagram.

For instance, the external control should only be enabled when the parking brake is applied.

The cables to the external control must also be twisted to avoid interference.

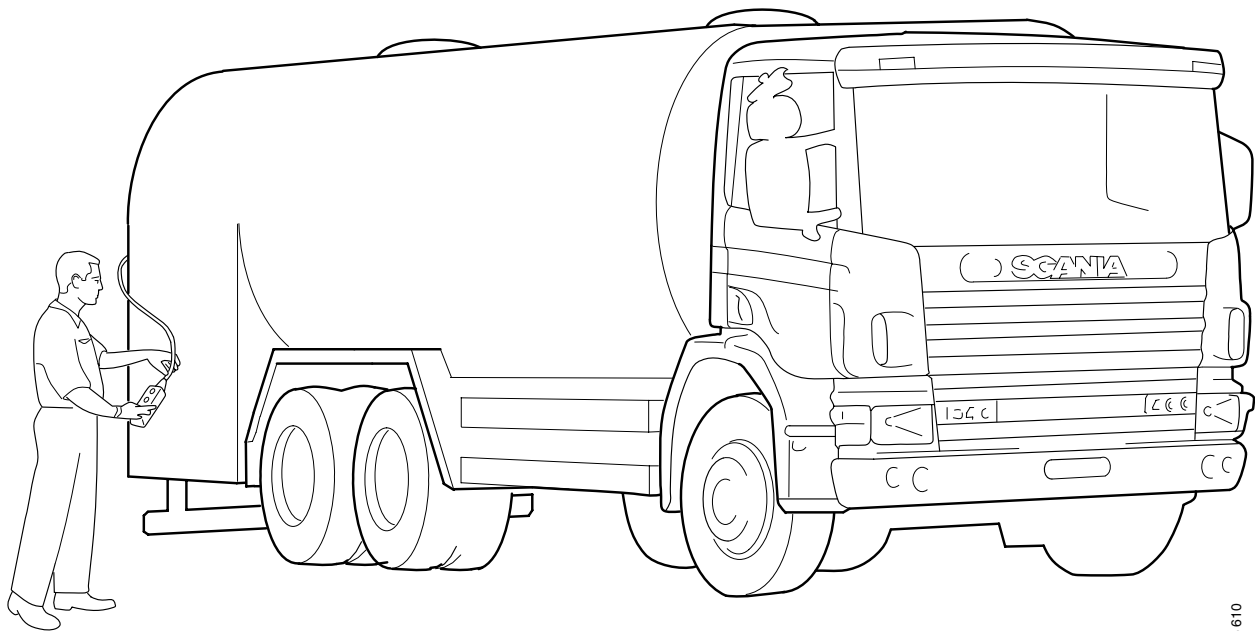

116610