

SCANIA

19:02-03

Issue 1 en

Retrofitting of coolbox

Work description

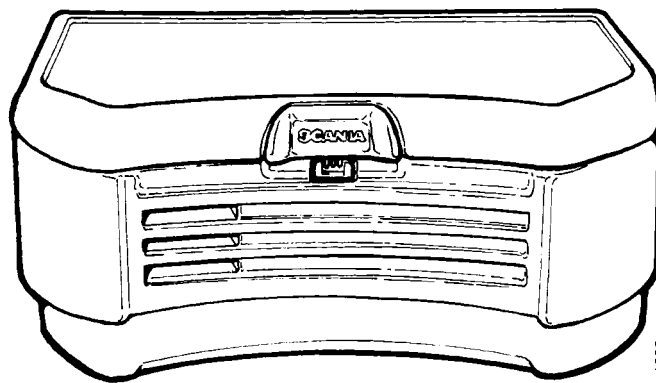

19_1632

Contents

General	General.....	3
Work description	Removal of interior equipment in CR cab with low floor	4
	Cable routing	
	Instrument wiring harness	7
	Floor wiring harness	8
	Modification of interior equipment	
	Alt. 1 Coolbox behind driver's seat	9
	Alt. 2 Coolbox on centre console	10
	Alt. 3 Coolbox behind/under passenger's seat.....	11
	Fitting of coolbox and interior equipment in CR19 cab with low floor.....	12
	Alt. 1 Coolbox behind driver's seat	13
	Alt. 2 Coolbox on centre console	16
	Alt. 3 Coolbox behind/under passenger's seat.....	18
	Fitting in P cabs and earlier R cabs with document compartment on centre console	21

General

The coolbox is a genuine Scania accessory for keeping food cool. It is specially manufactured for Scania and a number of places in the cab are prepared for it.

The location of the coolbox in the cab depends on the type of cab and its equipment level as well as the driver's own preference.

The description is based pictorially on the LHD 19 cab but the order in which the work is performed is the same in short cabs. On RHD vehicles the cable routing is mirror-reversed.

For operation and repair of the coolbox, see main group 19, Coolbox, description of operation and work description.

The following locations are possible in the CR cab with low floor:

Alt. 1 Coolbox behind driver's seat, suitable in the following cab types:

- CR19 cab with raised rear bunk, without SatCom system.

Alt. 2 Coolbox on centre console, suitable for the following cab types:

- CR14 cab.
- CR19 cab with two bunks.
- CR19 cab with raised rear bunk, without pull-out storage box.

Alt. 3 Coolbox behind/under passenger's seat, suitable for the following cab types:

- CR19 cab with raised bunk, without Eberspächer or legroom-adjustable passenger's seat.
- CR19 cab with two bunks, without Eberspächer or legroom-adjustable passenger's seat.

Work description

Removal of interior fittings in CR cab with low floor

Suitable parts of the description are applicable to CR cabs with low floor.

- 1 Withdraw the pull-out storage box and remove the insert.
- 2 Remove the rear storage box's lid, two screws at front. Remove the rear storage box, secured by four screws to the rear wall and two screws at the front.
- 3 Remove the trim on the centre console secured by velcro fasteners.

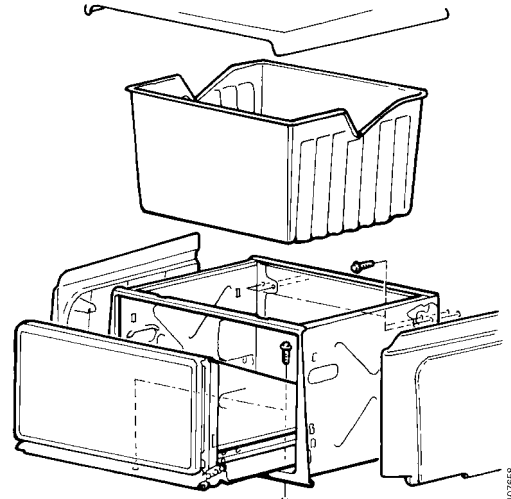

- 4 Remove the cover behind the driver's seat.
- 5 Remove the side of the storage box. Detach the heater hose on vehicles equipped with Eberspächer.

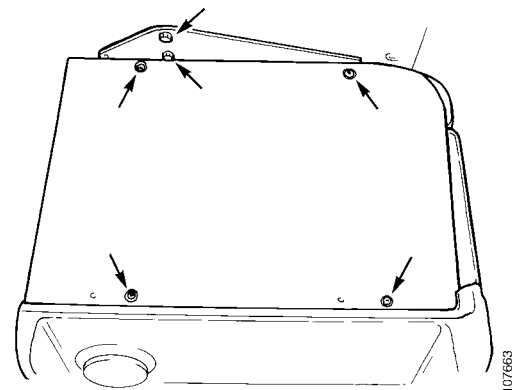

- 6 Slide the passenger's seat to its rearmost position or tip it up. Detach the gas cylinder and secure the seat in the raised position by means of a support strut.

Note: The gas spring is locked with a strip of sheet metal.

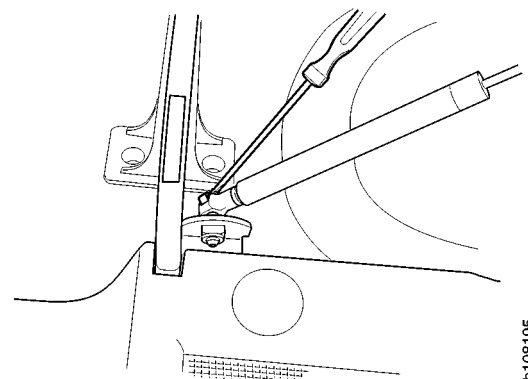

- 7 Detach the gas spring for the centre bunk section and the section behind the passenger seat. Secure the bunks in the raised position.

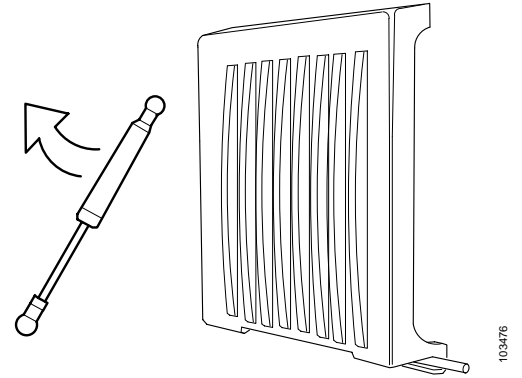

- 8 Remove the rear centre panel.

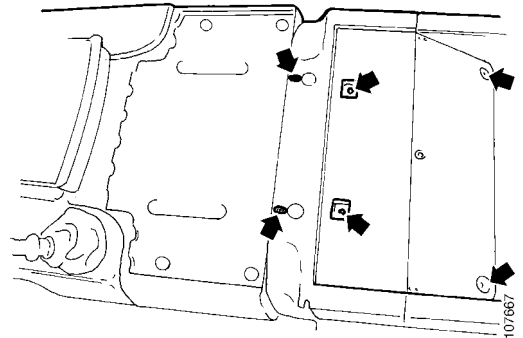

- 9 Remove the wood panel on the centre console.

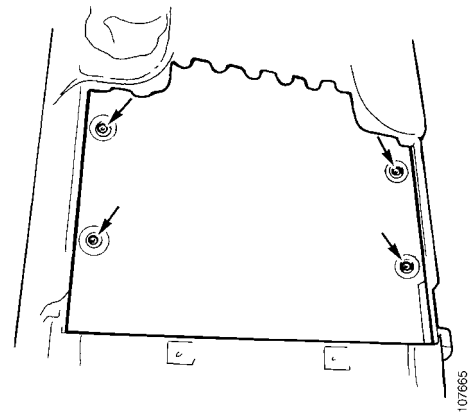

- 10 Remove the outer casing from the front storage box.

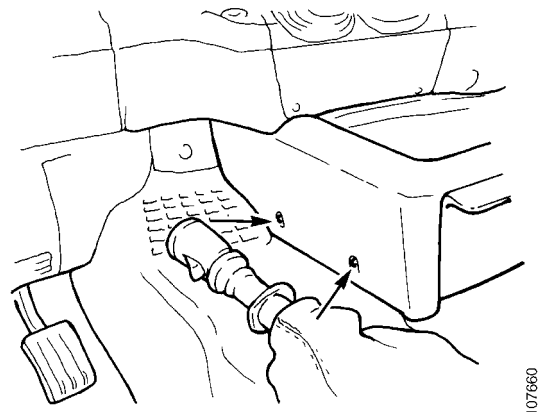

- 11 Pull out the box and remove the centre console retaining screws.
- 12 Remove the bottle holder.
- 13 Pull the gear lever gaiter off the centre console.

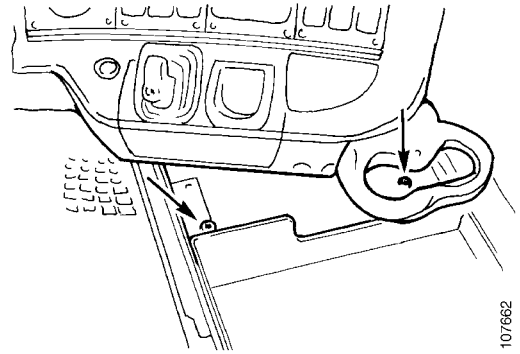

- 14 Remove the panel under the central electric unit and the panel under the centre section of the instrument panel.

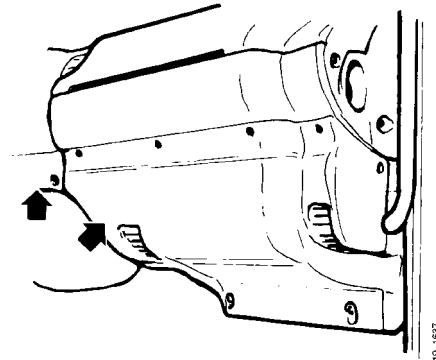

- 15 Remove centre console B.

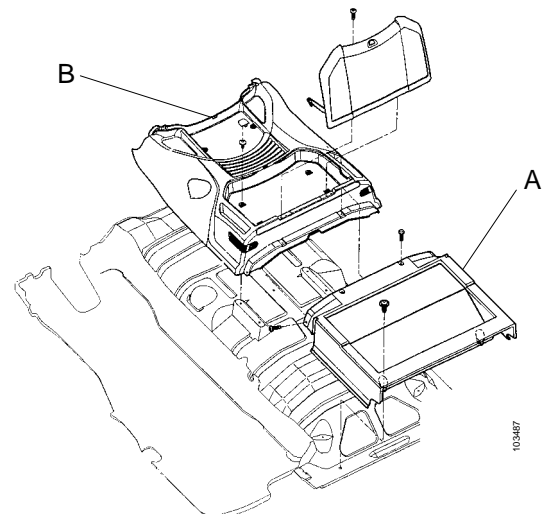

Cable routing

Instrument wiring harness

- 1 Remove fuse 35.

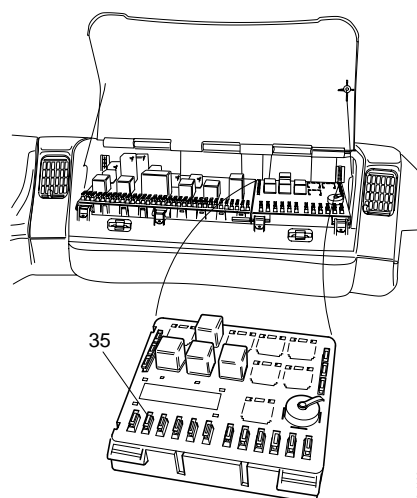

- 2 Connect the orange lead between central electric unit F1/35-C and C124 pin 3 in the connector panel on the left under the central electric unit.
If the vehicle has a manual exhaust brake, the connector must also be fitted.

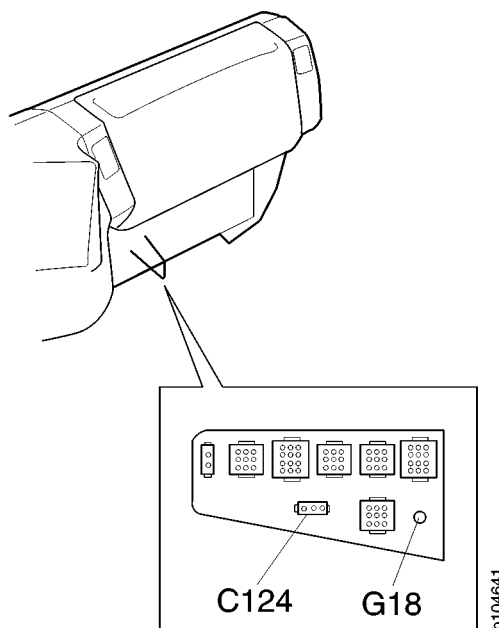
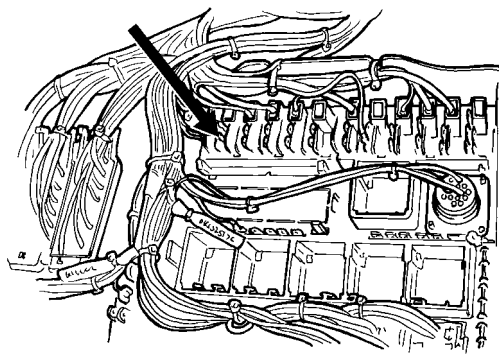

b104641

Floor wiring harness

1 Run the floor wiring harness as shown in the illustration to the place where the coolbox is to be installed.

- Alt. 1 Coolbox behind driver's seat (CR19 S and CR19 T)
- Alt. 2 Coolbox on centre console
- Alt. 3 Coolbox behind/under passenger seat

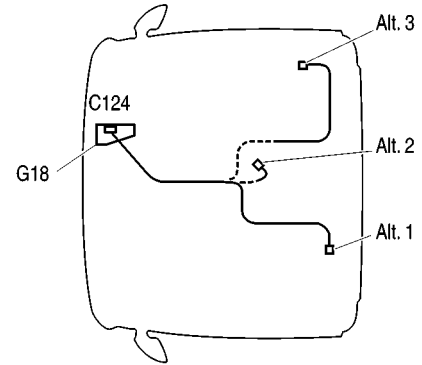

b108168

2 Connect lead 30G (OG) to C124 pin 3 and lead 31 (BK) to G18.

3 Run the lead along the wiring loom.

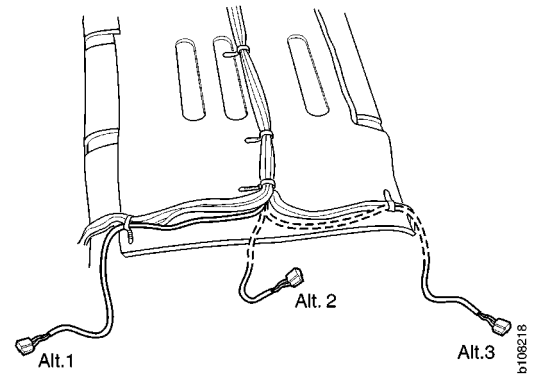

Modification of interior fittings

Alt. 1 Coolbox behind driver's seat

- 1 Drill a 20 mm hole in the rear centre panel.

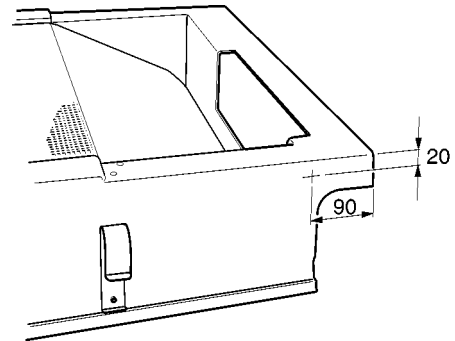

b108182

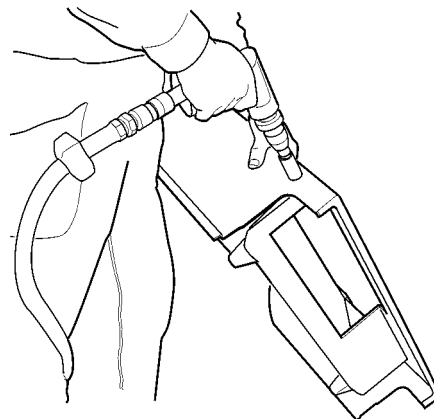

b108183

- 2 Drill a 20 mm hole in the cover behind the driver's seat.

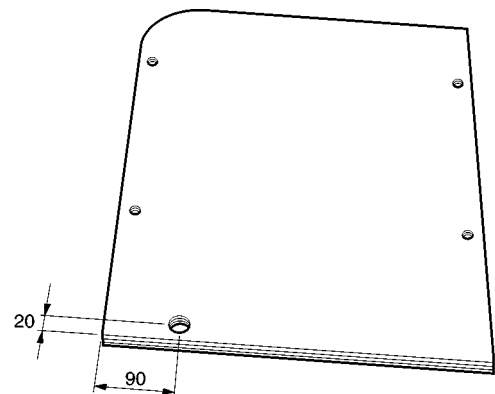

b108185

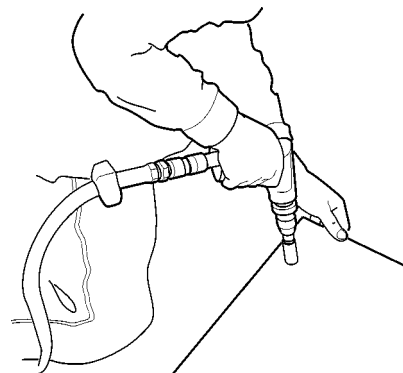

b108184

Alt. 2 Coolbox on centre console

- 1 Place the coolbox's mounting plate on the centre console, secure it with the screws and mark the place where the hole for the lead is to be drilled (diameter 20 mm).

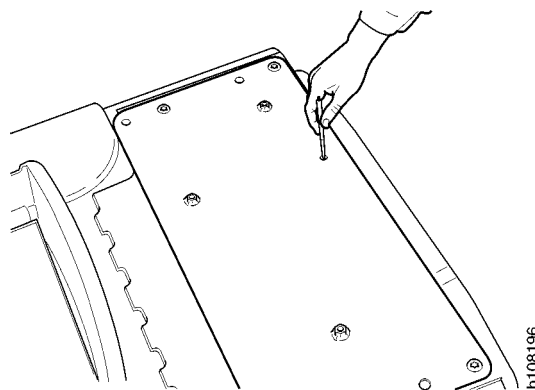

- 2 Remove the mounting plate and drill a 20 mm hole through the wood panel and centre console.

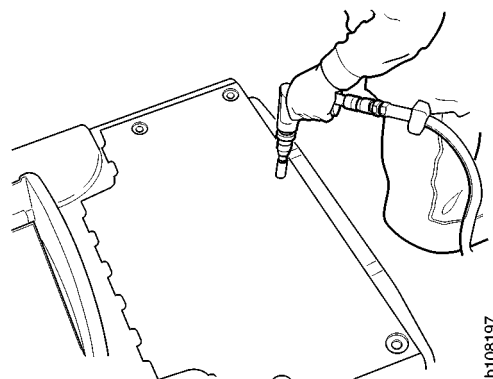

Alt. 3 Coolbox behind/under passenger seat.

This modification applies only to vehicles with raised bunk and reclining seat.

- 1 Remove the gas spring bracket from the reclining seat.
- 2 Mark and drill an 8.5 mm hole.

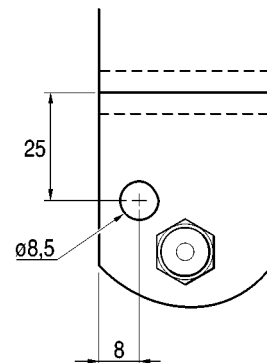

b108169

- 3 Cut off the gas spring's attaching lug.

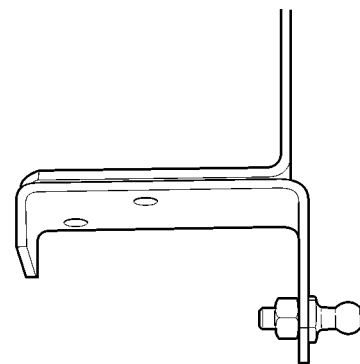

b108170

- 4 Fit the ball joint on the attaching lug, using an M8 nut.

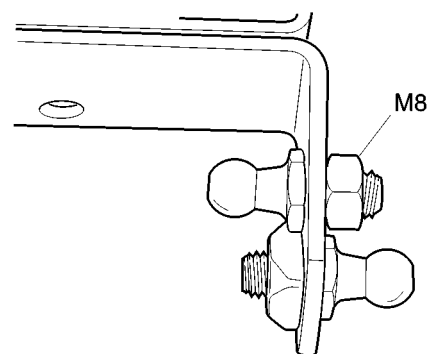

b108171

- 5 Fit the attaching lug on the reclining seat.

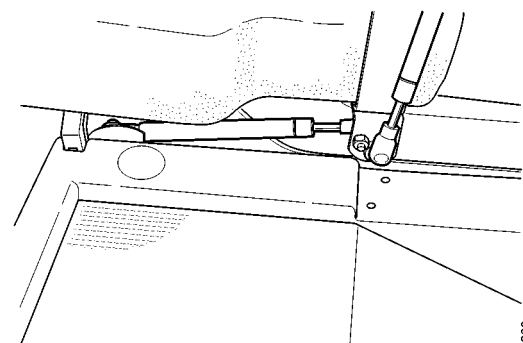

b108239

Fitting of coolbox and interior fittings on CR cab with low floor

- 1 Fit the centre console and wood panel, force the gear lever gaiter into place. On vehicles with the coolbox on the centre console, pull the lead through.

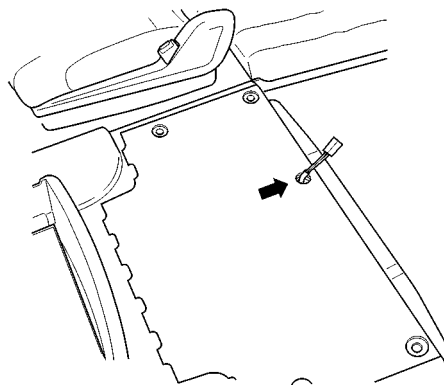

b108199

- 2 Fit the panel under the central electric unit and the panel under the centre section of the instrument panel.

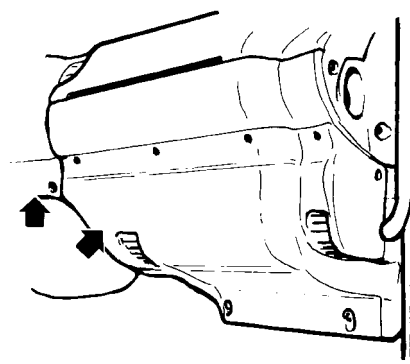

10_1637

- 3 Fit the front storage box and screw the centre console in place.

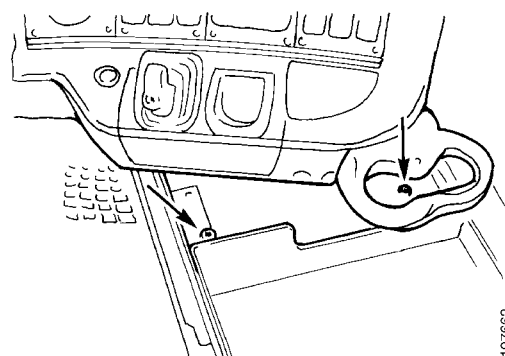

107662

- 4 Fit the outer casing on the storage box.
- 5 Unpack the coolbox.
- 6 Remove the cover over the compressor and unscrew the brackets from the coolbox. Discard the brackets as they are used only for CP cabs.

Note: Lift up the cover over the compressor with care to avoid damaging the thermostat.

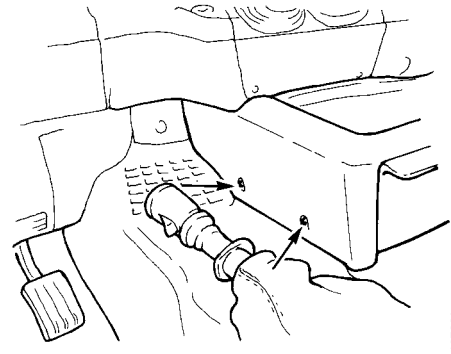

Alt. 1 Coolbox behind driver's seat

- 1 Fit the rear centre panel. Pull the lead through.

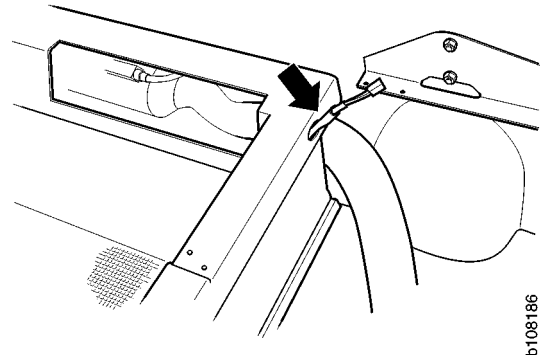

- 2 Fasten a cable tie to the rear centre panel to secure the seat belt buckle to the passenger's seat.
- 3 Fit the gas spring.

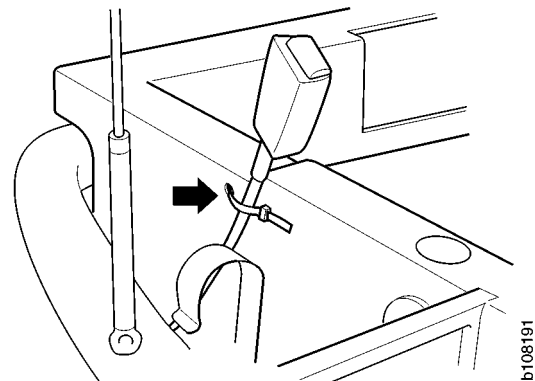

- 4 Fit the panel on centre console.

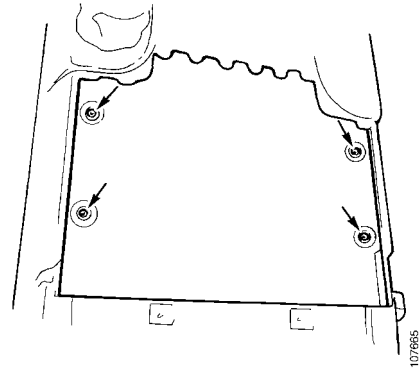

- 5 Fit the side of the storage box behind the driver's seat. On vehicles with Eberspächer, fit the heater hose.
- 6 Fit the lid of the storage compartment. Pull the lead through.

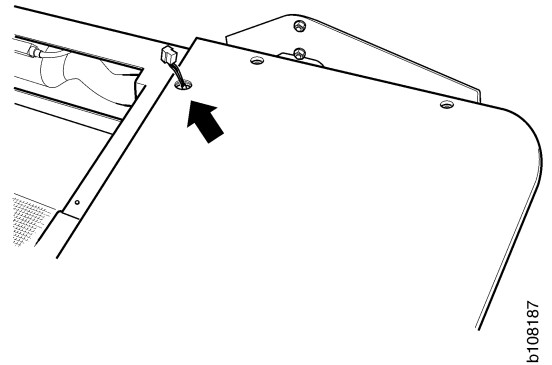

- 7 Fit the coolbox mounting plate. The two front screws should be 40 mm long, the rear screws 30 mm long.

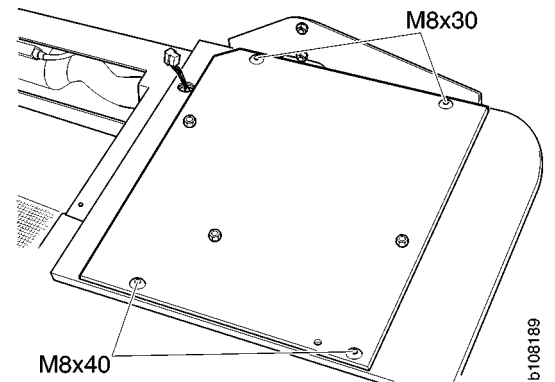

- 8 Position the plastic mat and make three holes in it for the coolbox retaining screws and one hole for the lead.

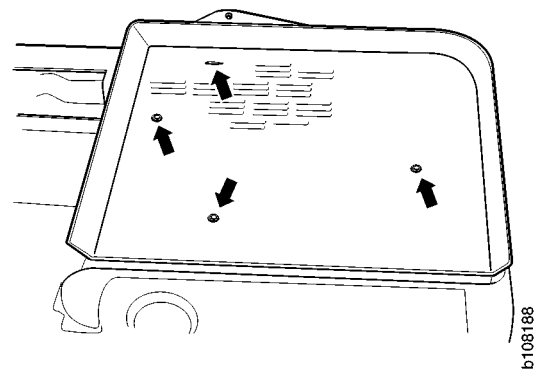

- 9 Lift the coolbox into place, plug in the connector under the plastic mat.
- 10 Screw the coolbox into place using three M8x30 mm screws.

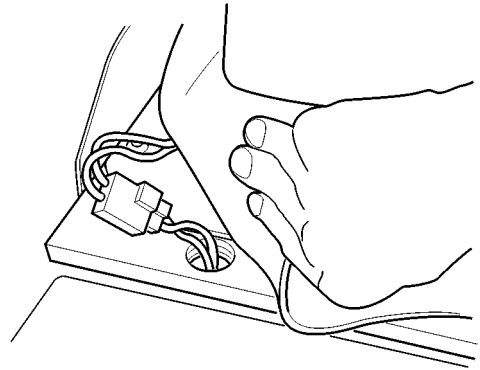

b108190

- 11 Fit the supplied cover plug over the screw in the refrigerated compartment.
- 12 Fit the cover over the compressor.

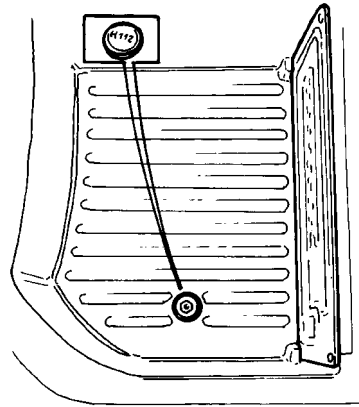

19_1033

- 13 Fit the centre console trim and secure it with the velcro fasteners.
- 14 Screw the rear storage box in position by means of four screws in the rear wall and two at the front. Lift the insert into place.
- 15 Fit fuse 35 in the central electric unit.

IMPORTANT! The coolbox should be placed right way up for at least one hour before installation. Clean it thoroughly on the inside using a soft cloth and ordinary dishwashing detergent. Do not use aggressive or abrasive cleaning agents. Wipe the coolbox dry after cleaning it.

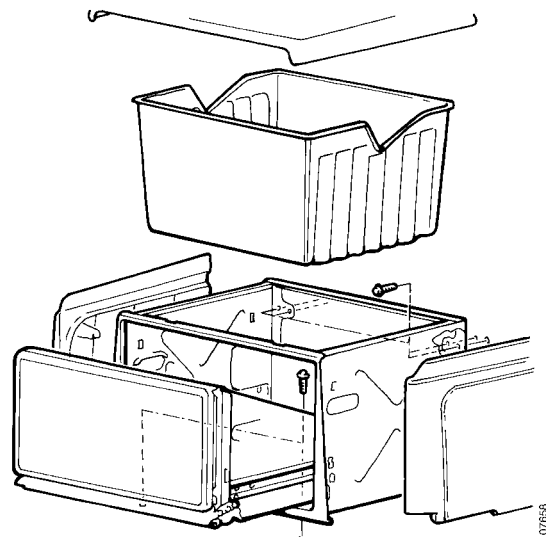

107655

Alt. 2 Coolbox on centre console

- 1 Position the coolbox mounting plate. Pull the lead through and screw the mounting plate in place.

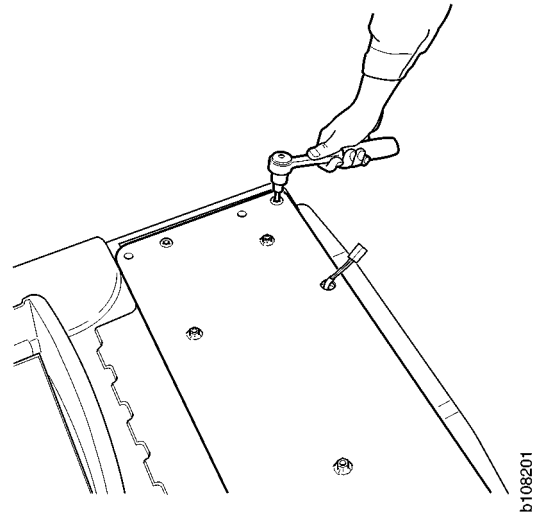

- 2 Fit the rear centre panel. Secure the gas springs to the bunk.

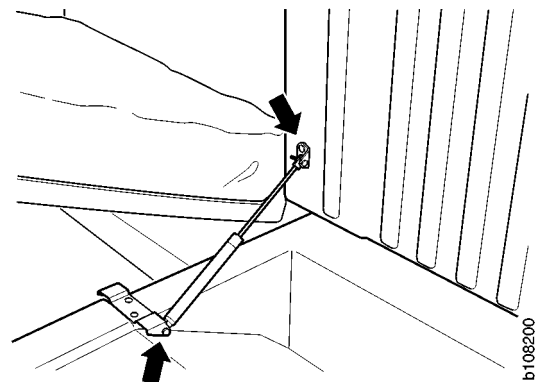

- 3 Fit the trim on the centre console and make holes for the coolbox retaining screws and the electric lead. Pull the lead through.

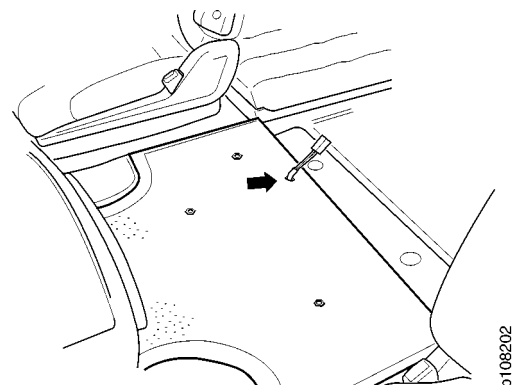

- 4 Lift the coolbox into place. Pull out the control unit from the rear.
- 5 Pull the connecting lead through and plug in the connector.
- 6 Push the connector and control unit back into the coolbox.

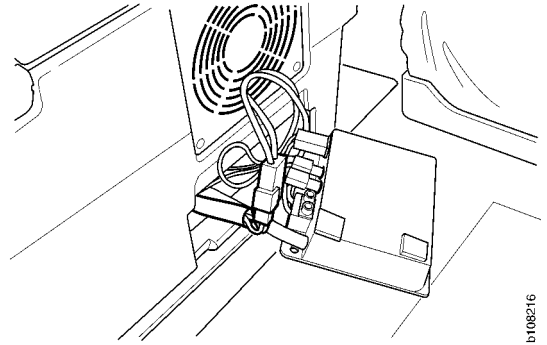

b108216

- 7 Screw the coolbox into place using three M8x30 mm screws.
- 8 Fit the supplied cover plug over the screw in the coolbox compartment.
- 9 Fit the cover over the compressor.

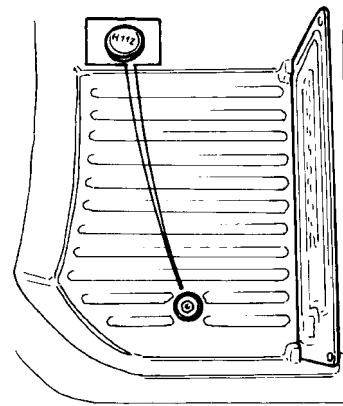

19_1053

- 10 Fit fuse 35 in the central electric unit.

IMPORTANT! The coolbox should be placed right way up for at least one hour before installation. Clean it thoroughly on the inside using a soft cloth and ordinary dishwashing detergent. Do not use aggressive or abrasive cleaning agents. Wipe the coolbox dry after cleaning it.

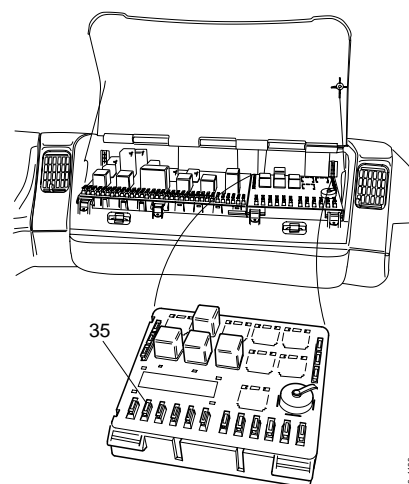

16_1188

Alt. 3 Coolbox behind/under passenger seat

- 1 Remove the passenger seat/reclining seat. The reclining seat's bracket must be modified, see Modification of interior fittings, alt. 3.
- 2 Fold the floor mat out of the way.
- 3 Remove the insulation over four predrilled screw holes.

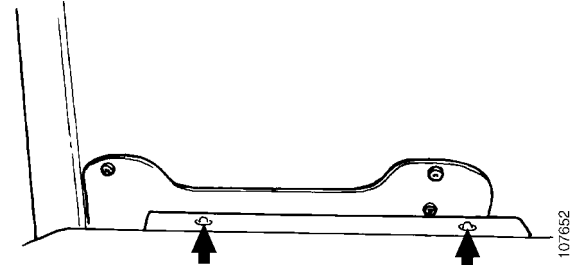

Reclining seat wall bracket.

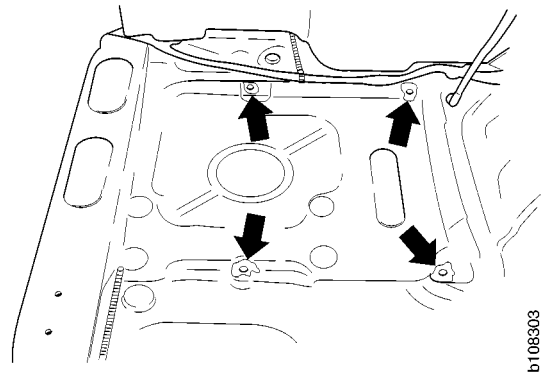
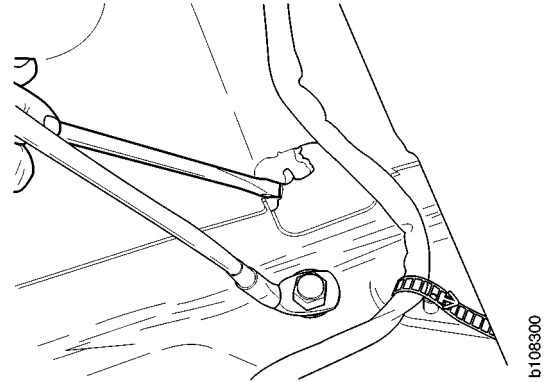

- 4 Fold the floor mat back into place and mark the positions of the holes. The two holes nearest the engine tunnel are already marked. Use the mounting plate as a template for the other holes.
- 5 Make six holes in the floor mat, five for the spacers and one for the lead.

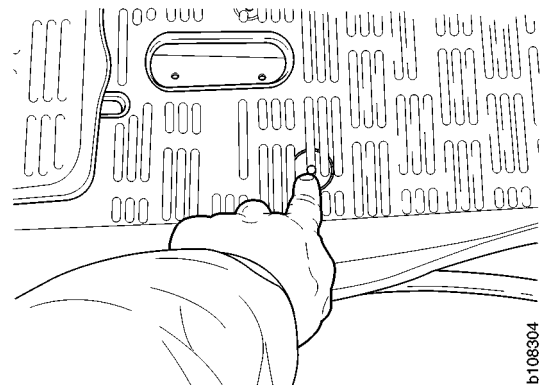

- 6 Fit the floor mat. Fit the spacers and pull the lead through.

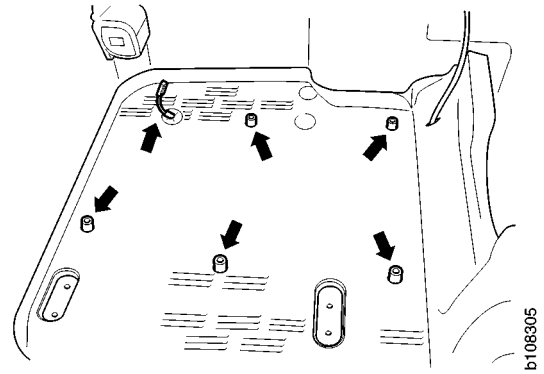

- 7 Fit the mounting plate with four M10x45 screws and one M6x50 screw.

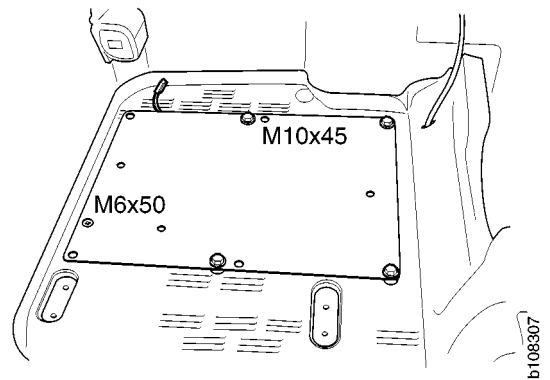

- 8 Fit the rear centre panel. Fasten a cable tie to the rear centre panel to secure the seat belt buckle to the passenger's seat.
- 9 Fit the side of the storage box behind the driver's seat and the bunk support strut previously removed.
- 10 Fit the lid of the storage compartment or bunk squabs.

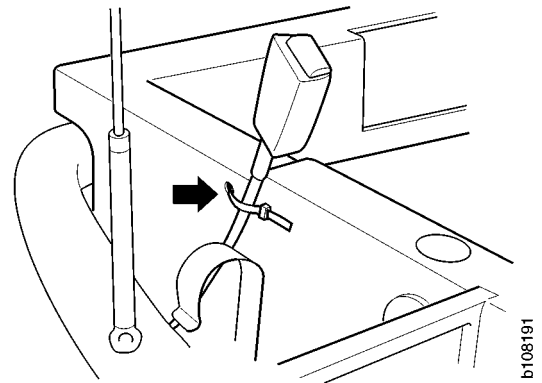

- 11 Lift the coolbox into place and plug in the connector.
- 12 Screw the coolbox into place using three M8x30 mm screws.
- 13 Fit the supplied cover plug over the screw in the coolbox compartment.
- 14 Fit the cover over the compressor.

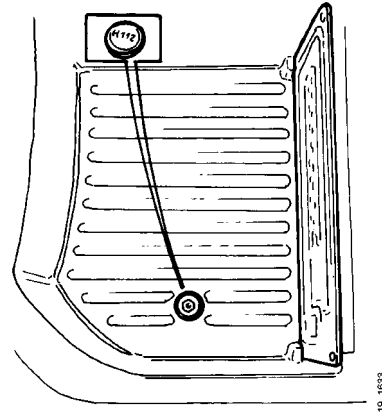

- 15 Fit the centre console trim and secure it with the velcro fasteners.
- 16 Screw the rear storage box in position by means of four screws in the rear wall and two at the front. Lift the insert into place.
- 17 Fit fuse 35 in the central electric unit.

IMPORTANT! The coolbox should be placed right way up for at least one hour before installation. Clean it thoroughly on the inside using a soft cloth and ordinary dishwashing detergent. Do not use aggressive or abrasive cleaning agents. Wipe the coolbox dry after cleaning it.

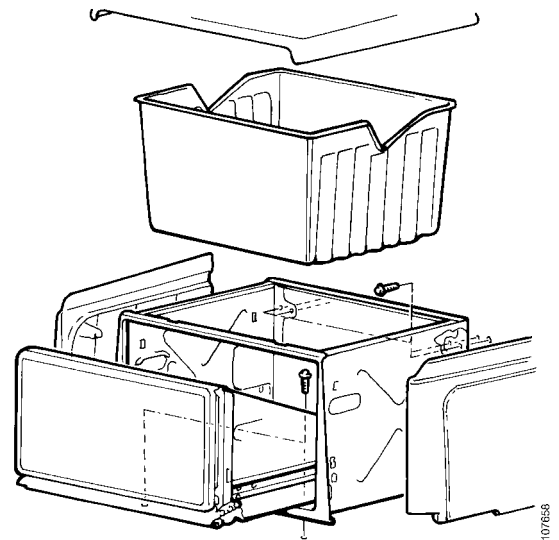

Fitting in P cab or earlier R cabs with document compartment on the centre console

- 1 Remove the panel under the central electric unit and the panel under the centre section of the instrument panel.

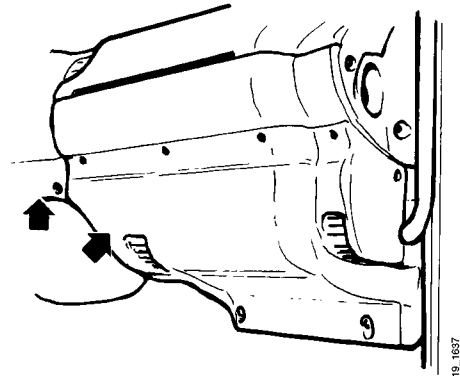

- 2 Remove the lid from the storage box. (Keep the lid for the vehicle owner).
- 3 Remove the retaining catches. (Keep them for the vehicle owner).

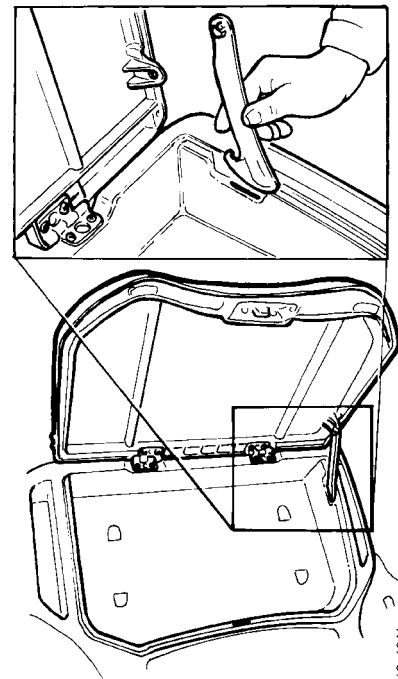

- 4 Use a knife to open the pre-marked hole in the bottom of the document compartment.

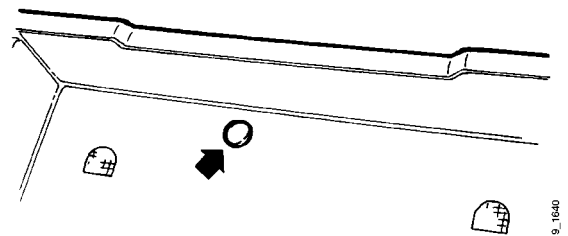

- 5 Remove the bunk from behind the driver's seat.
- 6 Remove the screws securing the rear centre cover, remove the gas spring and fold the cover rearwards.

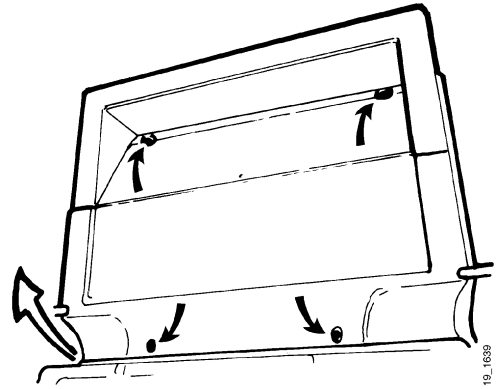

- 7 Remove the caps from the centre cover retaining screws. Remove the screws and lift the rear edge of the cover.

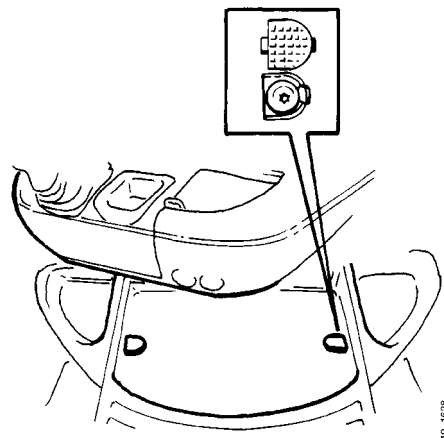

- 8 Route the cable supplied with the refrigerator along the existing wiring on the engine tunnel. Place the cable with the white marker tape beside the marker tape on the cables under the instrument panel in order to ensure that cable length is correct in both directions. Secure the cable using cable ties.

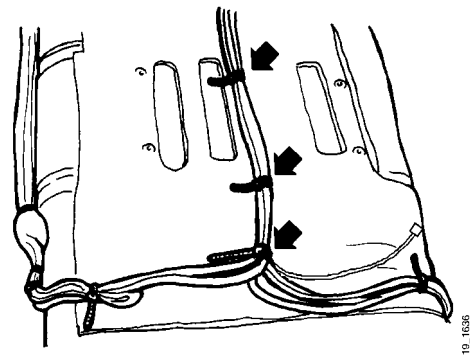

9 Run the orange lead to C124/3 in the connector panel on the left under the central electric unit. If the vehicle has a manual exhaust brake, connector C124 must also be fitted. Connect the black earth cable to G18.

10 Remove fuse 35.

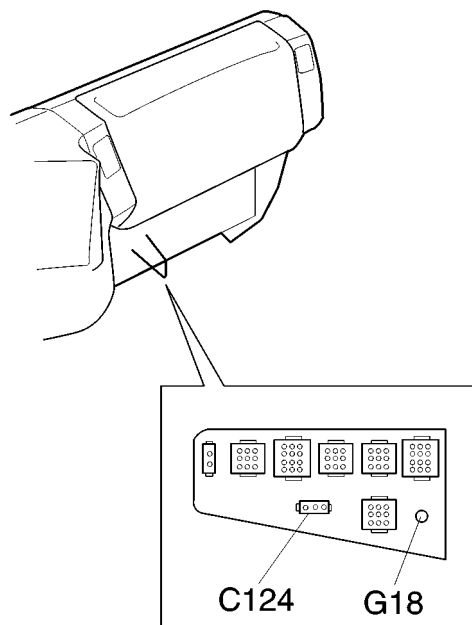

b104641

11 Connect the cable between central electric unit F1/35-C and C124/3 in the connector panel on the left under the central electric unit. If the truck is not fitted with a manual exhaust brake, the connector piece must also be fitted.

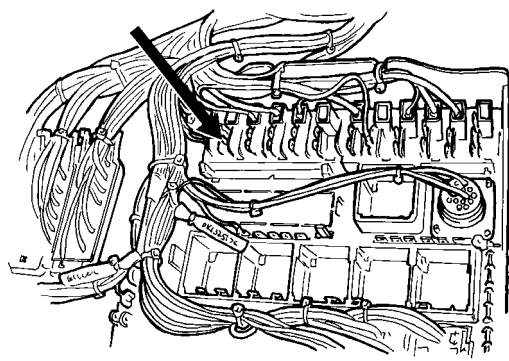

19_1655

12 Fit the centre cover. Make sure that the cable extends above the bottom of the storage box. Fit the two front securing screws and their caps. Fit the panels under the instrument panel.

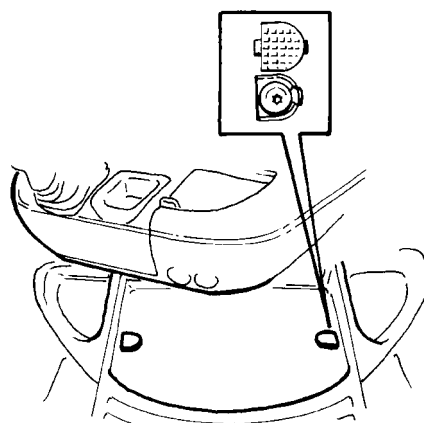

19_1636

- 13 Detach the cover from over the compressor and unscrew the brackets from the coolbox.
- 14 Fit the refrigerator brackets in the bottom of the storage box using new M8x50 screws. Do not tighten them.

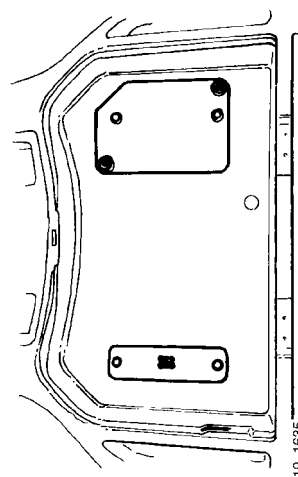

- 15 Place the coolbox in position. Adjust the brackets to the coolbox using the securing screws in the bottom of the box.
- 16 Undo the screws, raise the coolbox and tighten the brackets.
- 17 Connect the power supply. The splice should be located in the space in the bottom of the box.
- 18 Place the coolbox back in position and screw it down.
- 19 Replace the cover over the compressor.

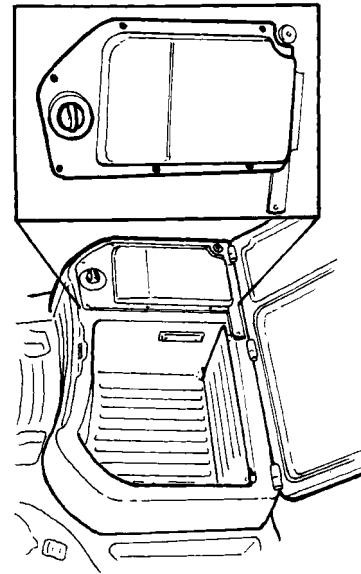

- 20 Place the supplied caps over the screws in the refrigerated compartment.
- 21 Fit fuse 35.

IMPORTANT! The coolbox should be placed right way up for at least one hour before installation. Clean it thoroughly on the inside using a soft cloth and ordinary dishwashing detergent. Do not use aggressive or abrasive cleaning agents. Wipe the coolbox dry after cleaning it.

